

AMENDMENT OF SOLICITATION/MODIFICATION OF CONTRACT	1. CONTRACT ID CODE	PAGE OF PAGES
		1 3

2. AMENDMENT/MODIFICATION NO. W9127826RA012-0003	3. EFFECTIVE DATE 12 MAY 2026	4. REQUISITION/PURCHASE	5. PROJECT NO. (If applicable) MEF22007
---	----------------------------------	-------------------------	--

6. ISSUED BY CODE		7. ADMINISTERED BY (If other than item 6) CODE
----------------------	--	---

8. NAME AND ADDRESS OF CONTRACTOR (No., street, county, State and ZIP code)	<input checked="" type="checkbox"/>	9A. AMENDMENT OF SOLICITATION NO. W9127826RA012
		9B. DATED (SEE ITEM 11) 16 MARCH 2026
	<input type="checkbox"/>	10A. MODIFICATION OF CONTRACT/ORDER NO.
		10B. DATED (SEE ITEM 13)

CODE	FACILITY CODE
------	---------------

11. THIS ITEM ONLY APPLIES TO AMENDMENTS OF SOLICITATIONS

The above numbered solicitation is amended as set forth in item 14. The hour and date specified for receipt of Offers is extended, is not extended. Offers must acknowledge receipt of this amendment prior to the hour and date specified in the solicitation or as amended, by one of the following methods: (a) By completing items 8 and 15, and returning _____ copies of the amendment; (b) By acknowledging receipt of this amendment on each copy of the offer submitted; or (c) By separate letter or telegram which includes a reference to the solicitation and amendment numbers. **FAILURE OF YOUR ACKNOWLEDGEMENT TO BE RECEIVED AT THE PLACE DESIGNATED FOR THE RECEIPT OF OFFERS PRIOR TO THE HOUR AND DATE SPECIFIED MAY RESULT IN REJECTION OF YOUR OFFER.** If by virtue of this amendment you desire to change an offer already submitted, such change may be made by telegram or letter, provided each telegram or letter makes reference to the solicitation and this amendment, and is received prior to the opening hour and date specified.

12. ACCOUNTING AND APPROPRIATION DATA (if required)

**13. THIS ITEM APPLIES ONLY TO MODIFICATIONS OF CONTRACTS/ORDERS,
IT MODIFIES THE CONTRACT/ORDER NO. AS DESCRIBED IN ITEM 14.**

<input type="checkbox"/>	A. THIS CHANGE ORDER IS ISSUED PURSUANT TO: (Specify authority) _____ THE CHANGES SET FORTH IN ITEM 14 ARE MADE IN THE CONTRACT ORDER NO. IN ITEM 10A
<input type="checkbox"/>	B. THE ABOVE NUMBERED CONTRACT/ORDER IS MODIFIED TO REFLECT ADMINISTRATIVE CHANGES (such as changes in paying office, appropriation date, etc.) SET FORTH IN ITEM 14, PURSUANT TO AUTHORITY OF FAR 43.103(b)
<input type="checkbox"/>	C. THIS SUPPLEMENTAL AGREEMENT IS ENTERED INTO PURSUANT TO AUTHORITY OF:
<input type="checkbox"/>	D. OTHER _____ (Specify type of modification and authority)

E. IMPORTANT: Contractor is not, is required to sign this document and return _____ copies to the issuing office.

14. DESCRIPTION OF AMENDMENT/MODIFICATION (Organized by UCF section headings, including solicitation/contract subject matter where feasible)

The subject solicitation for: **LRSO HARDWARE SOFTWARE DEVELOPMENT FACILITY
EGLIN AIR FORCE BASE, FLORIDA**

Is modified in the following: **REFER TO THE ENCLOSED REVISED SPECIFICATIONS FOR AMENDMENT NO. 0003**

Except as provided herein, all terms and conditions of the document reference in item 9A or 10A, as Heretofore changed, remains unchanged and in full force and effect.

15A. NAME AND TITLE OF SIGNER (Type or print)	16A. NAME AND TITLE OF CONTRACTING OFFICE (Type or print)
15B. CONTRACTOR/OFFEROR _____ (Signature of person authorized to sign)	15C. DATE SIGNED _____
16B. UNITED STATES OF AMERICA BY _____ (Signature of contracting officer)	16C. DATE SIGNED _____

PART I - REVISIONS MADE BY ADDED AND/OR REPLACEMENT PARAGRAPHS/PAGES/SECTIONS

The items listed below are to be replaced by the corresponding added and/or revised paragraphs/pages or sections. Added and/or revised paragraphs/pages or sections are indicated by a note in bottom right-hand corner of each paragraph or page. Added sections are hereby made a part of the contract and are to be inserted in the specification in the proper numerical/alphabetical sequence.

Within the specifications, deletions from the specifications are indicated by strikethrough, e.g.: ~~deletions are marked with strikethrough~~ and additions to the specifications including revisions/substitutions are indicated in bold, italic and underlined, e.g.: ***additions are indicated thus.***

<u>SECTION</u>	<u>Corresponding Added or Revised Paragraph Page, and/or Section</u>
<u>Volume 1</u>	
Table of Contents	Revised Page 3 and 5 as indicated herein.
SF1442	Revised Block 9.a, 9.b, and 13.a as indicated herein.
00 70 00	Replaced in its entirety.
01 00 00	Revised Paragraph 1.5 as indicated herein.
01 33 00	Replaced Submittal Register
03 30 00	Revised Paragraph 1.6.6.1 as indicated herein.
<u>Volume 2</u>	
Table of Contents	Revised Page 3 and 5 as indicated herein.
<u>Volume 3</u>	
Table of Contents	Revised Page 3 and 5 as indicated herein.
<u>Volume 4</u>	
Table of Contents	Revised Page 3 and 5 as indicated herein.
Appendix D	Revised Salient Characteristics on Data Sheets WS1.A, WS2a.A, WS2b.A, WS9a.A, WS9b.A, WS10a.A, and WS10b.A as indicated herein.
Appendix E	Added in its entirety.

PART II - REVISIONS MADE BY DELETED PAGES/SECTIONS

The pages and/or sections listed below are to be deleted from the specifications by the bidders and marked "DELETED":

08 34 01 Deleted in its entirety.

PART III - NOTE: Revised, replacement and added drawings are listed below. These revised, replacement and added drawings are to be inserted into the folio in the proper numerical sequence. Drawings that have been revised or replaced by this amendment shall be deleted from the folio. All drawings listed below are revised unless indicated otherwise.

Sheet Reference <u>Number</u>	<u>Title</u>
G-001	COVER SHEET
A-631	DOOR HARDWARE SCHEDULE
IF101	OVERALL FURNITURE PLAN
T-501	TELECOMMUNICATIONS DETAILS

Encl as stated:

Revised, Replaced or Added pages of the specifications as indicated in Part I.
Deleted pages of the specifications as indicated in Part II.
4 Revised drawings as indicated in Part III.

TABLE OF CONTENTS

VOLUME 1 OF 4

CHECKLIST FOR PREPARATION OF OFFERS
TABLE OF CONTENTS

CONTRACT CLAUSES

	STANDARD FORM 1442
	BIDDING SCHEDULE
	EXPLANATION OF BID ITEMS
	LIMITATIONS ON SUBCONTRACTING COMPLIANCE FORM
	STANDARD FORM 24 - BID BOND
	STANDARD FORM 28 - AFFIDAVIT OF INDIVIDUAL SURETY
	STANDARD FORM LLL - DISCLOSURE OF LOBBYING ACTIVITIES
00 11 00	PROPOSAL SUBMISSION REQUIREMENTS
00 12 00	SELECTION PROCEDURES AND BASIS OF AWARD
00 21 16	INSTRUCTIONS, CONDITIONS, & NOTICES TO OFFERORS
00 22 16	EVALUATION FACTORS FOR AWARD
00 45 00	REPRESENTATIONS, CERTIFICATION, & OTHER STATEMENTS
00 70 00	CONTRACT CLAUSES
00 73 00	SUPPLEMENTARY CONDITIONS
01 00 01	GENERAL CONTRACT REQUIREMENTS
	CESAM FORM 1151

SPECIFICATIONS

DIVISION 01 - GENERAL REQUIREMENTS

01 00 00	ADDITIONAL SPECIAL CONTRACT REQUIREMENTS
	EP310-1-6a PROJECT SIGNS
	DD FORM 1354
	DD FORM 1354 CHECKLIST
	WAGE RATES
01 14 00	WORK RESTRICTIONS
01 32 01.00 10	PROJECT SCHEDULE
01 33 00	SUBMITTAL PROCEDURES
	SUBMITTAL REGISTER
	ENG FORM 4025
01 33 29	SUSTAINABILITY REQUIREMENTS AND REPORTING
01 35 26	GOVERNMENTAL SAFETY REQUIREMENTS
01 42 00	SOURCES FOR REFERENCE PUBLICATIONS
01 45 00	QUALITY CONTROL
01 45 00.15 10	RESIDENT MANAGEMENT SYSTEM CONTRACTOR MODE (RMS CM)
	SAM FORM 696
01 45 35	SPECIAL INSPECTIONS
	ATTACHMENT A STATEMENT OF SPECIAL INSPECTIONS
	ATTACHMENT B SCHEDULE OF SPECIAL INSPECTIONS
	ATTACHMENT C CONTRACTOR'S STATEMENT OF RESPONSIBILITY
01 50 00	TEMPORARY CONSTRUCTION FACILITIES AND CONTROLS

DIVISION 01 - GENERAL REQUIREMENTS, CONTINUED

01 57 19 TEMPORARY ENVIRONMENTAL CONTROLS - EGLIN STANDARD
 ATTACHMENT A AF FORM 813 REQUEST FOR ENVIRONMENTAL
 IMPACT ANALYSIS
01 74 19 CONSTRUCTION WASTE MANAGEMENT AND DISPOSAL
01 78 00 CLOSEOUT SUBMITTALS
01 78 23 OPERATION AND MAINTENANCE DATA
01 91 00.15 10 BUILDING COMMISSIONING

DIVISION 03 - CONCRETE

03 30 00 CAST-IN-PLACE CONCRETE
03 54 13 GYPSUM CEMENT UNDERLAYMENT

DIVISION 04 - MASONRY

04 20 00 UNIT MASONRY

DIVISION 05 - METALS

05 05 20 POST-INSTALLED CONCRETE AND MASONRY ANCHORS
05 05 23.16 STRUCTURAL WELDING
05 30 00 STEEL DECKS
05 40 00 COLD-FORMED METAL FRAMING
05 44 00 PRE-ENGINEERED AND PRE-FABRICATED COLD-FORMED STEEL
 TRUSSES
05 50 13 MISCELLANEOUS METAL FABRICATIONS

DIVISION 06 - WOOD, PLASTICS, AND COMPOSITES

06 10 00 ROUGH CARPENTRY
06 12 13 SUBFLOOR PANEL
06 41 16.00 10 PLASTIC-LAMINATE-CLAD ARCHITECTURAL CABINETS
06 61 16 SOLID SURFACING FABRICATIONS

VOLUME 2 OF 4

DIVISION 07 - THERMAL AND MOISTURE PROTECTION

07 14 00 FLUID-APPLIED WATERPROOFING
07 21 16 MINERAL FIBER BLANKET INSULATION
07 22 00 ROOF AND DECK INSULATION
07 27 10 BUILDING AIR BARRIER SYSTEM
07 42 13 METAL WALL AND SOFFIT PANELS
07 60 00 FLASHING AND SHEET METAL
07 61 14.00 20 STEEL STANDING SEAM ROOFING
07 84 00 FIRESTOPPING
07 92 00 JOINT SEALANTS

DIVISION 08 - OPENINGS

08 11 13	STEEL DOORS AND FRAMES
08 31 00	ACCESS DOORS AND PANELS
08 34 01	FORCED ENTRY RESISTANT COMPONENTS
08 34 73	SOUND CONTROL DOOR ASSEMBLIES
08 51 23	STEEL WINDOWS
08 71 00	DOOR HARDWARE
08 81 00	GLAZING
08 91 00	METAL WALL LOUVERS
09 29 00	GYPSUM BOARD
09 30 10	CERAMIC, AND PORCELAIN TILING
09 62 38	STATIC-CONTROL FLOORING
09 65 00	RESILIENT FLOORING
09 67 23.14	CHEMICAL RESISTANT RESINOUS FLOORING
09 68 00	CARPETING
09 69 13	RIGID GRID ACCESS FLOORING
09 90 00	PAINTS AND COATINGS

DIVISION 10 - SPECIALTIES

10 11 00	VISUAL DISPLAY UNITS
10 14 00.10	EXTERIOR SIGNAGE
10 14 00.20	INTERIOR SIGNAGE
10 21 13	TOILET COMPARTMENTS
10 26 00	WALL AND DOOR PROTECTION
10 28 13	TOILET ACCESSORIES
10 44 16	FIRE EXTINGUISHERS
10 51 13	METAL LOCKERS

DIVISION 11 - EQUIPMENT

11 13 19.23	STATIONARY DOCK LIFT
-------------	----------------------

DIVISION 12 - FURNISHINGS

12 48 13	ENTRANCE FLOOR MATS
12 50 00.13 10	FURNITURE AND FURNITURE INSTALLATION
12 59 00	SYSTEMS FURNITURE

DIVISION 13 - SPECIAL CONSTRUCTION

13 49 20.00 10	RF SHIELDING
----------------	--------------

DIVISION 21 - FIRE SUPPRESSION

21 13 13	WET PIPE SPRINKLER SYSTEMS, FIRE PROTECTION
21 22 00	CLEAN AGENT FIRE EXTINGUISHING SYSTEM
21 30 10	FIRE PUMPS WITH DEDICATED ENCLOSURE

DIVISION 22 - PLUMBING

22 00 00	PLUMBING, GENERAL PURPOSE
----------	---------------------------

DIVISION 23 - HEATING, VENTILATING, AND AIR CONDITIONING (HVAC)

23 05 93 TESTING, ADJUSTING, AND BALANCING FOR HVAC
23 07 00 THERMAL INSULATION FOR MECHANICAL SYSTEMS
23 09 00 INSTRUMENTATION AND CONTROL FOR HVAC
23 09 13 INSTRUMENTATION AND CONTROL DEVICES FOR HVAC
23 09 23.02 BACNET DIRECT DIGITAL CONTROL FOR HVAC AND OTHER
BUILDING CONTROL SYSTEMS
23 23 00 REFRIGERANT PIPING
23 30 00 HVAC AIR DISTRIBUTION
23 81 00 DECENTRALIZED UNITARY HVAC EQUIPMENT
23 81 23 COMPUTER ROOM AIR CONDITIONING UNITS
23 83 00.00 20 ELECTRIC SPACE HEATING EQUIPMENT

VOLUME 3 OF 4

DIVISION 25 - INTEGRATED AUTOMATION

25 05 11.21 CYBERSECURITY FOR FACILITY-RELATED CONTROL SYSTEMS - FLS
25 05 11.25 CYBERSECURITY FOR FACILITY-RELATED CONTROL SYSTEMS - BCS
25 05 11.26 CYBERSECURITY FOR FACILITY-RELATED CONTROL SYSTEMS - UCS
25 05 11.28 CYBERSECURITY FOR FACILITY-RELATED CONTROL SYSTEMS - ESS
25 08 10 UTILITY MONITORING AND CONTROL SYSTEM TESTING
25 10 10 UTILITY MONITORING AND CONTROL SYSTEM (UMCS) FRONT END AND
INTEGRATION

DIVISION 26 - ELECTRICAL

26 05 73 POWER SYSTEM STUDIES
26 08 00 APPARATUS INSPECTION AND TESTING
26 20 00 INTERIOR DISTRIBUTION SYSTEM
26 27 13.10 30 ELECTRIC METERS
26 29 23 ADJUSTABLE SPEED DRIVE (ASD) SYSTEMS UNDER 600 VOLTS
26 32 15.00 ENGINE-GENERATOR SET STATIONARY 15-2500 KW, WITH
AUXILIARIES
26 33 53 STATIC UNINTERRUPTIBLE POWER SUPPLY (UPS)
26 36 23 AUTOMATIC TRANSFER SWITCHES AND BY-PASS/ISOLATION SWITCH
26 41 00 LIGHTNING PROTECTION SYSTEM
26 51 00 INTERIOR LIGHTING
26 56 00 EXTERIOR LIGHTING

DIVISION 27 - COMMUNICATIONS

27 10 00 BUILDING TELECOMMUNICATIONS CABLING SYSTEM

DIVISION 28 - ELECTRONIC SAFETY AND SECURITY

28 31 76 INTERIOR FIRE ALARM AND MASS NOTIFICATION SYSTEM,
ADDRESSABLE

DIVISION 31 - EARTHWORK

31 00 00 EARTHWORK

31 11 00 CLEARING AND GRUBBING

DIVISION 32 - EXTERIOR IMPROVEMENTS

32 01 19.61 SEALING OF JOINTS IN RIGID PAVEMENT
32 05 33 LANDSCAPE ESTABLISHMENT
32 11 23 AGGREGATE BASE COURS FOR FLEXIBLE PAVING
32 12 13 BITUMINOUS TACK AND PRIME COATS
32 12 16.16 ROAD-MIX ASPHALT PAVING
32 13 13.06 PORTLAND CEMENT CONCRETE PAVEMENT FOR ROADS AND SITE
FACILITIES
32 13 73.19 COMPRESSION CONCRETE PAVING JOINT SEALANT
32 16 19 CONCRETE CURBS, GUTTERS AND SIDEWALKS
32 17 23 PAVEMENT MARKINGS
32 92 19 SEEDING

DIVISION 33 - UTILITIES

33 01 50.31 LEAK DETECTION FOR FUELING SYSTEMS
33 11 00 WATER UTILITY DISTRIBUTION PIPING
33 30 00 SANITARY SEWERAGE
33 40 00 STORMWATER UTILITIES
33 71 02 UNDERGROUND ELECTRICAL DISTRIBUTION
33 82 00 TELECOMMUNICATIONS OUTSIDE PLANT (OSP)

VOLUME 4 OF 4

APPENDICES

APPENDIX A JUSTIFICATION AND APPROVAL (J&A) FOR CUMMINS DIESEL
GENERATOR
APPENDIX B JUSTIFICATION AND APPROVAL (J&A) FOR HEATING,
VENTILATION, AND AIR CONDITIONING (HVAC)
APPENDIX C JUSTIFICATION AND APPROVAL (J&A) FOR ONYX NOTIFIER FIRE
ALARM CONTROL PANEL (FACP)
APPENDIX D FURNITURE, FIXTURES, AND EQUIPMENT (FF&E)
APPENDIX E CONSTRUCTION SECURITY PLAN (CSP)

-- End of Project Table of Contents --

SOLICITATION, OFFER AND AWARD <i>(Construction, Alteration, or Repair)</i>		1. SOLICITATION NUMBER W9127826RA012	2. TYPE OF SOLICITATION <input type="checkbox"/> SEALED BID (IFB) INVITATION FOR BID <input checked="" type="checkbox"/> NEGOTIATED (RFP) REQUEST FOR PROPOSAL	3. DATE ISSUED 16 MAR 2026	PAGE OF PAGES 1 2
IMPORTANT - The "offer" section on the reverse must be fully completed by offeror.					
4. CONTRACT NO.		5. REQUISITION/PURCHASE REQUEST NO.	6. PROJECT NUMBER MEF22007		
7. ISSUED BY U.S. ARMY ENGINEER DISTRICT, MOBILE CONTRACTING DIVISION (CESAM-CT) 100 CANAL STREET MOBILE, AL 36628-0001		CODE CT	8. ADDRESS OFFER TO SAME AS BLOCK 7		
9. FOR INFORMATION CALL: ▶		a. NAME Leigh Dedrick Justin Tarver / Stephanie Scalise		b. TELEPHONE NO. (Include area code) (NO COLLECT CALLS) (251) 441-5519 (251) 234-5141 / (251) 690-2479	

SOLICITATION

NOTE: In sealed bid solicitations "offer" and "offeror" mean "bid" and "bidder".

10. THE GOVERNMENT REQUIRES PERFORMANCE OF THE WORK DESCRIBED IN THESE DOCUMENTS (Title, identifying no., date):

LRSO HARDWARE SOFTWARE DEVELOPMENT FACILITY, EGLIN AIR FORCE BASE, FLORIDA

* See Section 01 00 00, Paragraph "COMMENCEMENT, PROSECUTION AND COMPLETION OF WORK".

**Block 13A. Offeror shall submit their proposal through PIEE.

11. The contractor shall begin performance within 8 calendar days and complete it within * calendar days after receiving
 award, notice to proceed. This performance period is mandatory, negotiable. (See _____.)

12a. THE CONTRACTOR MUST FURNISH ANY REQUIRED PERFORMANCE AND PAYMENT BONDS? (If "YES," indicates within how many calendar days after award in Item 12b.) <input checked="" type="checkbox"/> YES <input type="checkbox"/> NO	12b. CALENDAR DAYS 10
--	-------------------------------------

13. ADDITIONAL SOLICITATION REQUIREMENTS:

a. Sealed offers in original and ** copies to perform the work required are due at the place specified in Item 8 by 1400 (hour) local time **22 14-MAY 2026** (date). If this is a sealed bid solicitation, offers must be publicly opened at that time. Sealed envelopes containing offers shall be marked to show the offeror's name and address, the solicitation number, and the date and time offers are due.

b. An offer guarantee is, is not required.

c. All offers are subject to the (1) work requirements, and (2) other provisions and clauses incorporated in the solicitation in full text or by reference.

d. Offers providing less than 120 calendar days for Government acceptance after the date offers are due will not be considered and will be rejected.

OFFER (Must be fully completed by offeror)

14. NAME AND ADDRESS OF OFFEROR (Include ZIP Code)	15. TELEPHONE NO. (Include area code)
	16. REMITTANCE ADDRESS (Include only if different than Item 14.)
CODE	FACILITY CODE

17. The offeror agrees to perform the work required at the prices specified below in strict accordance with the terms of this solicitation, if this offer is accepted by the Government in writing within _____ calendar days after the date offers are due. (Insert any number equal to or greater than the minimum requirement stated in Item 13d. Failure to insert any number means the offeror accepts the minimum in Item 13d.)

AMOUNTS 

18. The offeror agrees to furnish any required performance and payment bonds.

19. ACKNOWLEDGMENT OF AMENDMENTS

(The offeror acknowledges receipt of amendments to the solicitation - give number and date of each)

AMENDMENT NUMBER										
DATE										

20a. NAME AND TITLE OF PERSON AUTHORIZED TO SIGN OFFER (Type or print)	20b. SIGNATURE	20c. OFFER DATE
---	----------------	-----------------

AWARD (To be completed by Government)

21. ITEMS ACCEPTED:

22. AMOUNT	23. ACCOUNTING AND APPROPRIATION DATA	
24. SUBMIT INVOICES TO ADDRESS SHOWN IN (4 copies unless otherwise specified) 	ITEM	25. OTHER THAN FULL AND OPEN COMPETITION PURSUANT TO <input type="checkbox"/> 10 U.S.C. 3204(a) () <input type="checkbox"/> 41 U.S.C. 3304(a) ()
26. ADMINISTERED BY CODE		27. PAYMENT WILL BE MADE BY

CONTRACTING OFFICER WILL COMPLETE ITEM 28 OR 29 AS APPLICABLE

<input type="checkbox"/> 28. NEGOTIATED AGREEMENT (Contractor is required to sign this document and return _____ copies to issuing office.) Contractor agrees to furnish and deliver all items or perform all work, requisitions identified on this form and any continuation sheets for the consideration stated in this contract. The rights and obligations of the parties to this contract shall be governed by (a) this contract award, (b) the solicitation, and (c) the clauses, representations, certifications, and specifications incorporated by reference in or attached to this contract.	<input type="checkbox"/> 29. AWARD (Contractor is not required to sign this document.) Your offer on this solicitation is hereby accepted as to the items listed. This award consummates the contract, which consists of (a) the Government solicitation and your offer, and (b) this contract award. No further contractual document is necessary.		
30a. NAME AND TITLE OF CONTRACTOR OR PERSON AUTHORIZED TO SIGN (Type or print)	31a. NAME OF CONTRACTING OFFICER (Type or print)		
30b. SIGNATURE	30c. DATE	31b. UNITED STATES OF AMERICA BY	31c. AWARD DATE

STANDARD FORM 1442 (REV12/2022) BACK

Section 00 70 00 - Contract Clauses

FAR Clauses Incorporated by Reference

Number	Title	Effective Date	Alternate Deviation	Variation Effective Date
52.203-3	Gratuities.	1984-04		
52.203-5	Covenant Against Contingent Fees.	2014-05		
52.203-6	Restrictions on Subcontractor Sales to the Government.	2020-06		
52.203-7	Anti-Kickback Procedures.	2020-06		
52.203-8	Cancellation, Rescission, and Recovery of Funds for Illegal or Improper Activity.	2014-05		
52.203-10	Price or Fee Adjustment for Illegal or Improper Activity.	2014-05		
52.203-12	Limitation on Payments to Influence Certain Federal Transactions.	2020-06		
52.203-13	Contractor Code of Business Ethics and Conduct.	2021-11		
52.203-19	Prohibition on Requiring Certain Internal Confidentiality Agreements or Statements.	2017-01		
52.204-9	Personal Identity Verification of Contractor Personnel.	2011-01		
52.204-10	Reporting Executive Compensation and First-Tier Subcontract Awards.	2026-02		
52.204-13	System for Award Management-Maintenance.	2026-02		
52.204-19	Incorporation by Reference of Representations and Certifications.	2014-12		

52.209-6	Protecting the Government's Interest When Subcontracting With Contractors Debarred, Suspended, Proposed for Debarment, or Voluntarily Excluded.	2026-02		
52.209-9	Updates of Publicly Available Information Regarding Responsibility Matters.	2026-02		
52.209-10	Prohibition on Contracting With Inverted Domestic Corporations.	2026-02		
52.210-1	Market Research.	2026-02		
52.215-2	Audit and Records-Negotiation.	2026-02		
52.215-11	Price Reduction for Defective Certified Cost or Pricing Data -- Modifications (DEVIATION 2022-O0001)	2026-02	Deviation 2022- O0001	2021-10
52.215-13	Subcontractor Certified Cost or Pricing Data -- Modifications (Deviation 2022-O0001)	2026-02	Deviation 2022- O0001	2021-10
52.215-21	Requirements for Certified Cost or Pricing Data and Data Other Than Certified Cost or Pricing Data-Modifications.	2026-02		
52.215-21	Requirements for Certified Cost or Pricing Data and Data Other Than Certified Cost or Pricing Data-Modifications. (Alternate II)	2026-02	Alternate II	1997-10
52.219-6	Notice of Total Small Business Set-Aside.	2026-02		
52.219-8	Utilization of Small Business Concerns.	2026-02		
52.222-3	Convict Labor.	2026-02		
52.222-4	Contract Work Hours and Safety Standards-Overtime Compensation.	2026-02		
52.222-6	Construction Wage Rate Requirements.	2026-02		
52.222-7	Withholding of Funds.	2026-02		

52.222-8	Payrolls and Basic Records.	2026-02		
52.222-9	Apprentices and Trainees.	2026-02		
52.222-9	Apprentices and Trainees. (DEVIATION 2025-O0003)	2026-02	Deviation 2025-O0003	2025-03
52.222-10	Compliance with Copeland Act Requirements.	2026-02		
52.222-11	Subcontracts (Labor Standards).	2026-02		
52.222-12	Contract Termination-Debarment.	2014-05		
52.222-13	Compliance with Construction Wage Rate Requirements and Related Regulations.	2014-05		
52.222-14	Disputes Concerning Labor Standards.	2026-02		
52.222-15	Certification of Eligibility.	2014-05		
52.222-30	Construction Wage Rate Requirements-Price Adjustment (None or Separately Specified Method).	2018-08		
52.222-35	Equal Opportunity for Veterans.	2026-02		
52.222-36	Equal Opportunity for Workers with Disabilities.	2026-02		
52.222-37	Employment Reports on Veterans.	2026-02		
52.222-40	Notification of Employee Rights Under the National Labor Relations Act.	2010-12		
52.222-50	Combating Trafficking in Persons.	2026-02		
52.222-54	Employment Eligibility Verification.	2025-01		
52.222-55	Minimum Wages for Contractor Workers Under Executive Order 14026.	2026-02		

52.222-62	Paid Sick Leave Under Executive Order 13706.	2022-01		
52.222-90	Addressing DEI Discrimination by Federal Contractors (Deviation 2026-O0038	2026-02		
52.223-2	Reporting of Biobased Products Under Service and Construction Contracts.	2026-02		
52.223-5	Pollution Prevention and Right-to-Know Information.	2024-05		
52.223-23	Sustainable Products and Services. (DEVIATION 2025-O0004)	2026-02	Deviation 2025-O0004	2025-03
52.224-3	Privacy Training.	2017-01		
52.224-3	Privacy Training. (Alternate I)	2017-01	Alternate I	2017-01
52.226-7	Drug-Free Workplace.	2024-05		
52.226-8	Encouraging Contractor Policies to Ban Text Messaging While Driving.	2024-05		
52.227-1	Authorization and Consent.	2020-06		
52.227-2	Notice and Assistance Regarding Patent and Copyright Infringement.	2020-06		
52.227-4	Patent Indemnity-Construction Contracts.	2007-12		
52.228-2	Additional Bond Security.	1997-10		
52.228-5	Insurance-Work on a Government Installation.	1997-01		
52.228-11	Pledges of Assets (DEVIATION 2020-O0016)	2021-02	Deviation 2020-O0016	2020-04
52.228-12	Prospective Subcontractor Requests for Bonds.	2022-12		
52.228-14	Irrevocable Letter of Credit.	2014-11		

52.229-3	Federal, State, and Local Taxes.	2013-02
52.229-12	Tax on Certain Foreign Procurements.	2021-02
52.232-8	Discounts for Prompt Payment.	2002-02
52.232-17	Interest.	2014-05
52.232-23	Assignment of Claims.	2014-05
52.232-27	Prompt Payment for Construction Contracts.	2017-01
52.232-33	Payment by Electronic Funds Transfer-System for Award Management.	2018-10
52.232-39	Unenforceability of Unauthorized Obligations.	2013-06
52.232-40	Providing Accelerated Payments to Small Business Subcontractors.	2023-03
52.233-1	Disputes.	2026-02
52.233-3	Protest after Award.	2026-02
52.233-4	Applicable Law for Breach of Contract Claim.	2026-02
52.236-2	Differing Site Conditions.	2026-02
52.236-3	Site Investigation and Conditions Affecting the Work.	2026-02
52.236-5	Material and Workmanship.	2026-02
52.236-6	Superintendence by the Contractor.	2026-02
52.236-7	Permits and Responsibilities.	2026-02
52.236-8	Other Contracts.	2026-02
52.236-9	Protection of Existing Vegetation, Structures, Equipment, Utilities, and	2026-02

Improvements.

52.236-10	Operations and Storage Areas.	2026-02		
52.236-11	Use and Possession Prior to Completion.	2026-02		
52.236-12	Cleaning Up.	2026-02		
52.236-13	Accident Prevention.	2026-02		
52.236-13	Accident Prevention. (Alternate I)	2026-02	Alternate I	1991-11
52.236-15	Schedules for Construction Contracts.	2026-02		
52.236-17	Layout of Work.	2026-02		
52.236-21	Specifications and Drawings for Construction.	2026-02		
52.240-91	Security Prohibitions and Exclusions.	2026-02		
52.240-93	Basic Safeguarding of Covered Contractor Information Systems.	2026-02		
52.242-13	Bankruptcy.	1995-07		
52.242-14	Suspension of Work.	1984-04		
52.243-4	Changes.	2026-02		
52.244-6	Subcontracts for Commercial Products and Commercial Services.	2026-02		
52.244-6	Subcontracts for Commercial Products and Commercial Services. (DEVIATION 2025-O0003)	2026-02	Deviation 2025-O0003	2025-03
52.246-21	Warranty of Construction.	1994-03		
52.248-3	Value Engineering-Construction. (Alternate I)	2025-10	Alternate I	1984-04
52.249-2	Termination for Convenience of the	2012-04		

Government (Fixed-Price).

52.249-2	Termination for Convenience of the Government (Fixed-Price). (Alternate I)	2012-04	Alternate I	1996-09
52.249-10	Default (Fixed-Price Construction).	1984-04		
52.253-1	Computer Generated Forms.	1991-01		

DFARS Clauses Incorporated by Reference

Number	Title	Effective Date	Alternate Deviation	Variation Effective Date
252.203-7000	Requirements Relating to Compensation of Former DoD Officials.	2011-09		
252.203-7001	Prohibition on Persons Convicted of Fraud or Other Defense-Contract-Related Felonies.	2023-01		
252.203-7002	Requirement to Inform Employees of Whistleblower Rights.	2022-12		
252.203-7003	Agency Office of the Inspector General.	2019-08		
252.203-7004	Display of Hotline Posters.	2023-01		
252.204-7000	Disclosure of Information.	2016-10		
252.204-7003	Control of Government Personnel Work Product.	1992-04		
252.204-7004	Antiterrorism Awareness Training for Contractors.	2023-01		
252.204-7012	Safeguarding Covered Defense Information and Cyber Incident Reporting. (DEVIATION 2024-O0013)	2024-05	Deviation 2024-O0013	2024-05

REVISION 1)

252.204-7018	Prohibition on the Acquisition of Covered Defense Telecommunications Equipment or Services.	2023-01		
252.205-7000	Provision of Information to Cooperative Agreement Holders.	2024-10		
252.209-7004	Subcontracting with Firms that are Owned or Controlled by the Government of a Country that is a State Sponsor of Terrorism.	2019-05		
252.222-7006	Restrictions on the Use of Mandatory Arbitration Agreements.	2023-01		
252.223-7006	Prohibition on Storage, Treatment, and Disposal of Toxic or Hazardous Materials.	2014-09		
252.223-7008	Prohibition of Hexavalent Chromium.	2023-01		
252.225-7012	Preference for Certain Domestic Commodities.	2022-04		
252.225-7048	Export-Controlled Items.	2013-06		
252.225-7056	Prohibition Regarding Business Operations with the Maduro Regime.	2023-01		
252.225-7058	Postaward Disclosure of Employment of Individuals Who Work in the People's Republic of China.	2023-01		
252.225-7060	Prohibition on Certain Procurements from the Xinjiang Uyghur Autonomous Region.	2023-06		
252.225-7967	Prohibition Regarding Russian Fossil Fuel Business Operations (Deviation 2024-O0006, Revision 1)	2024-02	Deviation 2024- O0006	2024-02

252.225-7972	Prohibition on the Procurement of Foreign-Made Unmanned Aircraft Systems. (DEVIATION 2024-O0014)	2024-08	Deviation 2024-O0014	2024-08
252.226-7003	Drug-Free Work Force.	2024-08		
252.227-7033	Rights in Shop Drawings.	1966-04		
252.232-7010	Levies on Contract Payments.	2006-12		
252.236-7005	Airfield Safety Precautions.	1991-12		
252.236-7013	Requirement for Competition Opportunity for American Steel Producers, Fabricators, and Manufacturers.	2023-01		
252.243-7001	Pricing of Contract Modifications.	1991-12		
252.243-7002	Requests for Equitable Adjustment.	2022-12		
252.246-7004	Safety of Facilities, Infrastructure, and Equipment for Military Operations.	2010-10		
252.247-7023	Transportation of Supplies by Sea.	2024-10		

FAR Clauses Incorporated by Full Text

Number	Title	Effective Date	Alternate Deviation	Variation Effective Date
52.211-12	Liquidated Damages-Construction.	2000-09		

Liquidated Damages-Construction (Sept 2000)

(a) If the Contractor fails to complete the work within the time specified in the contract, the Contractor shall pay liquidated damages to the Government in the amount of See Section 01 00 00 for each calendar day of delay until the work is completed or accepted.

(b) If the Government terminates the Contractor's right to proceed, liquidated damages will continue to accrue until the work is completed. These liquidated damages are in addition to excess costs of repurchase under the Termination clause.

(End of clause)

52.215-21	Requirements for Certified Cost or Pricing Data and Data Other Than Certified Cost or Pricing Data-Modifications. (Alternate I)	2026-02	Alternate I	2026-02
-----------	---	---------	-------------	---------

Alternate I-(Feb 2026). As prescribed in 15.110(u)(1), substitute the following paragraph (b) (1) for paragraph (b)(1) of the basic clause.

(b)(1) The Contractor shall submit certified cost or pricing data, data other than certified cost or pricing data, and supporting attachments prepared in the following format: _____
[Insert description of the data and format that are required and include access to records necessary to permit an adequate evaluation of the proposed price in accordance with 15.408-2, Table 15-1, Note 2. The description may be inserted at the time of issuing the request for proposals, or the Contracting Officer may specify that the offeror's format will be acceptable, or the description may be inserted as the result of negotiations.]

52.215-21	Requirements for Certified Cost or Pricing Data and Data Other Than Certified Cost or Pricing Data-Modifications. (Alternate III)	2026-02	Alternate III	1997-10
-----------	---	---------	---------------	---------

Alternate III (Oct 1997). As prescribed in 15.408 (m), add the following paragraph (c) to the basic clause (if Alternate II is also used, redesignate the following paragraph as paragraph (d)):

(c) Submit the cost portion of the proposal via the following electronic media: ____ [Insert media format]

52.219-14	Limitations on Subcontracting (DEVIATION 2021-O0008)	2026-02	Deviation 2021- O0008	2023-02
-----------	---	---------	-----------------------------	---------

LIMITATIONS ON SUBCONTRACTING (FEB 2023) (DEVIATION 2021-O0008)

(a) This clause does not apply to the unrestricted portion of a partial set-aside.

(b) Definition. Similarly situated entity, as used in this clause, means a first-tier subcontractor, including an independent contractor, that--

(1) Has the same small business program status as that which qualified the prime contractor for the award (e.g., for a small business set-aside contract, any small business concern, without regard to its socioeconomic status); and

(2) Is considered small for the size standard under the North American Industry Classification System (NAICS) code the prime contractor assigned to the subcontract.

(c) Applicability. This clause applies only to--

(1) Contracts that have been set aside for any of the small business concerns identified in 19.000(a)(3);

(2) Part or parts of a multiple-award contract that have been set aside for any of the small business concerns identified in 19.000(a)(3);

(3) Contracts that have been awarded on a sole-source basis in accordance with subparts 19.8, 19.13, 19.14, and 19.15;

(4) Orders expected to exceed the simplified acquisition threshold and that are--

(i) Set aside for small business concerns under multiple-award contracts, as described in 8.405-5 and 16.505(b)(2)(i)(F); or

(ii) Issued directly to small business concerns under multiple-award contracts as described in 19.504(c)(1)(ii);

(5) Orders, regardless of dollar value, that are--

(i) Set aside in accordance with subparts 19.8, 19.13, 19.14, or 19.15 under multiple-award

contracts, as described in 8.405-5 and 16.505(b)(2)(i)(F); or

(ii) Issued directly to concerns that qualify for the programs described in subparts 19.8, 19.13, 19.14, or 19.15 under multiple-award contracts, as described in 19.504(c)(1)(ii); and

(6) Contracts using the HUBZone price evaluation preference to award to a HUBZone small business concern unless the concern waived the evaluation preference.

(d) Independent contractors. An independent contractor shall be considered a subcontractor.

(e) Limitations on subcontracting. By submission of an offer and execution of a contract, the Contractor agrees that in performance of a contract assigned a North American Industry Classification System (NAICS) code for--

(1) Services (except construction), it will not pay more than 50 percent of the amount paid by the Government for contract performance, excluding certain other direct costs and certain work performed outside the United States (see paragraph (e)(1)(i)), to subcontractors that are not similarly situated entities. Any work that a similarly situated entity further subcontracts will count towards the prime contractor's 50 percent subcontract amount that cannot be exceeded. When a contract includes both services and supplies, the 50 percent limitation shall apply only to the service portion of the contract. The following services may be excluded from the 50 percent limitation:

(i) Other direct costs, to the extent they are not the principal purpose of the acquisition and small business concerns do not provide the service. Examples include airline travel, work performed by a transportation or disposal entity under a contract assigned the environmental remediation NAICS code 562910), cloud computing services, or mass media purchases.

(ii) Work performed outside the United States on awards made pursuant to the Foreign Assistance Act of 1961, or work performed outside the United States required to be performed by a local contractor.

(2) Supplies (other than procurement from a nonmanufacturer of such supplies), it will not pay more than 50 percent of the amount paid by the Government for contract performance, excluding the cost of materials, to subcontractors that are not similarly situated entities. Any work that a similarly situated entity further subcontracts will count towards the prime contractor's 50 percent subcontract amount that cannot be exceeded. When a contract includes both supplies and services, the 50 percent limitation shall apply only to the supply portion of the contract;

(3) General construction, it will not pay more than 85 percent of the amount paid by the Government for contract performance, excluding the cost of materials, to subcontractors that

are not similarly situated entities. Any work that a similarly situated entity further subcontracts will count towards the prime contractor's 85 percent subcontract amount that cannot be exceeded; or

(4) Construction by special trade contractors, it will not pay more than 75 percent of the amount paid by the Government for contract performance, excluding the cost of materials, to subcontractors that are not similarly situated entities. Any work that a similarly situated entity further subcontracts will count towards the prime contractor's 75 percent subcontract amount that cannot be exceeded.

(f) The Contractor shall comply with the limitations on subcontracting as follows:

(1) For contracts, in accordance with paragraphs (c)(1), (2), (3) and (6) of this clause--

[Contracting Officer check as appropriate.]

By the end of the base term of the contract and then by the end of each subsequent option period; or

By the end of the performance period for each order issued under the contract.

(2) For orders, in accordance with paragraphs (c)(4) and (5) of this clause, by the end of the performance period for the order.

(g) A joint venture agrees that, in the performance of the contract, the applicable percentage specified in paragraph (e) of this clause will be performed by the aggregate of the joint venture participants.

(1) In a joint venture comprised of a small business protégé and its mentor approved by the Small Business Administration, the small business protégé shall perform at least 40 percent of the work performed by the joint venture. Work performed by the small business protégé in the joint venture must be more than administrative functions.

(2) In an 8(a) joint venture, the 8(a) participant(s) shall perform at least 40 percent of the work performed by the joint venture. Work performed by the 8(a) participants in the joint venture must be more than administrative functions.

(End of clause)

52.219-28 Postaward Small Business Program 2026-02
Rerepresentation.

Postaward Small Business Program Rerepresentation (Feb 2026)

(a) Definitions. As used in this clause-

Long-term contract means a contract of more than five years in duration, including options. However, the term does not include contracts that exceed five years in duration because the period of performance has been extended for a cumulative period not to exceed six months under the clause at 52.217-8, Option to Extend Services, or other appropriate authority.

Small business concern-

(1) Means a concern, including its affiliates, that is independently owned and operated, not dominant in its field of operation, and qualified as a small business under the criteria in 13 CFR part 121 and the size standard in paragraph (c) of this clause.

(2) Affiliates, as used in this definition, means business concerns, one of whom directly or indirectly controls or has the power to control the others, or a third party or parties control or have the power to control the others. In determining whether affiliation exists, consideration is given to all appropriate factors including common ownership, common management, and contractual relationships. SBA determines affiliation based on the factors set forth at 13 CFR 121.103.

(b) If the Contractor represented that it was a small business concern, a small disadvantaged business concern, or a joint venture that was any of the small business concerns identified in 19.000(a)(3) prior to award of this contract, the Contractor shall rerepresent its size and socioeconomic status according to paragraph (e) of this clause or, if applicable, paragraph (g) of this clause, upon occurrence of any of the following:

(1) Within 30 days after execution of a novation agreement or within 30 days after modification of the contract to include this clause, if the novation agreement was executed prior to inclusion of this clause in the contract.

(2) Within 30 days after a merger or acquisition that does not require a novation or within 30 days after modification of the contract to include this clause, if the merger or acquisition occurred prior to inclusion of this clause in the contract.

(3) For long-term contracts-

- (i) Within 60 to 120 days prior to the end of the fifth year of the contract; and
 - (ii) Within 60 to 120 days prior to the date specified in the contract for exercising any option thereafter.
- (c) The Contractor shall rerepresent its size status in accordance with the size standard in effect at the time of this rerepresentation that corresponds to the North American Industry Classification System (NAICS) code(s) assigned to this contract. The small business size standard corresponding to this NAICS code(s) can be found at <https://www.sba.gov/document/support-table-size-standards>.
- (d) The small business size standard for a Contractor providing an end item that it does not manufacture, process, or produce itself, for a contract other than a construction or service contract, is 500 employees, or 150 employees for information technology value-added resellers under NAICS code 541519, if the acquisition-
- (1) Was set aside for small business and has a value above the simplified acquisition threshold;
 - (2) Used the HUBZone price evaluation preference regardless of dollar value, unless the Contractor waived the price evaluation preference; or
 - (3) Was an 8(a), HUBZone, service-disabled veteran-owned, economically disadvantaged women-owned, or women-owned small business set-aside or sole-source award regardless of dollar value.
- (e) Except as provided in paragraph (g) of this clause, the Contractor shall make the representation(s) required by paragraph (b) of this clause by validating or updating all its representations in the Representations and Certifications section of the System for Award Management (SAM) and its other data in SAM, as necessary, to ensure that they reflect the Contractor's current status. The Contractor shall notify the contracting officer in writing within the timeframes specified in paragraph (b) of this clause, that the data have been validated or updated, and provide the date of the validation or update.
- (f) If the Contractor represented that it was other than a small business concern prior to award of this contract, the Contractor may, but is not required to, take the actions required by paragraphs (e) or (g) of this clause.
- (g) If the Contractor does not have representations and certifications in SAM, or does not have a representation in SAM for the NAICS code applicable to this contract, the Contractor is required to complete the following rerepresentation and submit it to the contracting office,

along with the contract number and the date on which the rerepresentation was completed:

(1) The Contractor represents that it is, is not a small business concern under ____NAICS Code assigned to ____contract number.

(2) [Complete only if the Contractor represented itself as a small business concern in paragraph (g)(1) of this clause.] The Contractor represents that it is, is not, a small disadvantaged business concern as defined in 13 CFR 124.1001.

(3) Women-owned small business (WOSB) joint venture eligible under the WOSB Program. The Contractor represents that it is, is not a joint venture that complies with the requirements of 13 CFR 127.506(a) through (c). [____The Contractor shall enter the name and unique entity identifier of each party to the joint venture: ____.]

(4) Economically disadvantaged women-owned small business (EDWOSB) joint venture. The Contractor represents that it is, is not a joint venture that complies with the requirements of 13 CFR 127.506(a) through (c). [____The Contractor shall enter the name and unique entity identifier of each party to the joint venture: ____.]

(5) Service-disabled veteran-owned small business (SDVOSB) joint venture eligible under the SDVOSB Program. The Contractor represents that it is, is not an SDVOSB joint venture eligible under the SDVOSB Program that complies with the requirements of 13 CFR 128.402. [____The Contractor shall enter the name and unique entity identifier of each party to the joint venture: ____.]

(6) HUBZone joint venture eligible under the HUBZone Program.[Complete only if the offeror is a HUBZone small business concern.] The offeror represents, as part of its offer, that It is, is not a HUBZone joint venture that complies with the requirements of 13 CFR 126.616(a) through (c). [____The Contractor shall enter the name and unique entity identifier of each party to the joint venture: .] Each HUBZone small business concern participating in the HUBZone joint venture must be certified as a HUBZone concern. [____Contractor to sign and date and insert authorized signer's name and title.]

(End of clause)

52.225-11 Buy American-Construction Materials 2026-02
under Trade Agreements.

Buy American-Construction Materials under Trade Agreements (Feb 2026)

(a) Definitions. As used in this clause-

Caribbean Basin country construction material means a construction material that-

- (1) Is wholly the growth, product, or manufacture of a Caribbean Basin country; or
- (2) In the case of a construction material that consists in whole or in part of materials from another country, has been substantially transformed in a Caribbean Basin country into a new and different construction material distinct from the materials from which it was transformed.

Commercially available off-the-shelf (COTS) item-

- (1) Means any item of supply (including construction material) that is-
 - (i) A commercial product (as defined in paragraph (1) of the definition of "commercial product" at Federal Acquisition Regulation (FAR) 2.101);
 - (ii) Sold in substantial quantities in the commercial marketplace; and
 - (iii) Offered to the Government, under a contract or subcontract at any tier, without modification, in the same form in which it is sold in the commercial marketplace; and
- (2) Does not include bulk cargo, as defined in 46 U.S.C. 40102(4), such as agricultural products and petroleum products.

Component means an article, material, or supply incorporated directly into a construction material.

Construction material means an article, material, or supply brought to the construction site by the Contractor or subcontractor for incorporation into the building or work. The term also includes an item brought to the site preassembled from articles, materials, or supplies. However, emergency life safety systems, such as emergency lighting, fire alarm, and audio evacuation systems, that are discrete systems incorporated into a public building or work and that are produced as complete systems, are evaluated as a single and distinct construction material regardless of when or how the individual parts or components of those systems are delivered to the construction site. Materials purchased directly by the Government are supplies, not construction material.

Cost of components means-

(1) For components purchased by the Contractor, the acquisition cost, including transportation costs to the place of incorporation into the construction material (whether or not such costs are paid to a domestic firm), and any applicable duty (whether or not a duty-free entry certificate is issued); or

(2) For components manufactured by the Contractor, all costs associated with the manufacture of the component, including transportation costs as described in paragraph (1) of this definition, plus allocable overhead costs, but excluding profit. Cost of components does not include any costs associated with the manufacture of the construction material.

Critical component means a component that is mined, produced, or manufactured in the United States and deemed critical to the U.S. supply chain. The list of critical components is at FAR 25.105.

Critical item means a domestic construction material or domestic end product that is deemed critical to U.S. supply chain resiliency. The list of critical items is at FAR 25.105.

Designated country means any of the following countries:

(1) A World Trade Organization Government Procurement Agreement (WTO GPA) country (Armenia, Aruba, Australia, Austria, Belgium, Bulgaria, Canada, Croatia, Cyprus, Czech Republic, Denmark, Estonia, Finland, France, Germany, Greece, Hong Kong, Hungary, Iceland, Ireland, Israel, Italy, Japan, Korea (Republic of), Latvia, Liechtenstein, Lithuania, Luxembourg, Malta, Moldova, Montenegro, Netherlands, New Zealand, North Macedonia, Norway, Poland, Portugal, Romania, Singapore, Slovak Republic, Slovenia, Spain, Sweden, Switzerland, Taiwan, Ukraine, or United Kingdom);

(2) A Free Trade Agreement (FTA) country (Australia, Bahrain, Chile, Colombia, Costa Rica, Dominican Republic, El Salvador, Guatemala, Honduras, Korea (Republic of), Mexico, Morocco, Nicaragua, Oman, Panama, Peru, or Singapore);

(3) A least developed country (Afghanistan, Angola, Bangladesh, Benin, Bhutan, Burkina Faso, Burundi, Cambodia, Central African Republic, Chad, Comoros, Democratic Republic of Congo, Djibouti, Equatorial Guinea, Eritrea, Ethiopia, Gambia, Guinea, Guinea-Bissau, Haiti, Kiribati, Laos, Lesotho, Liberia, Madagascar, Malawi, Mali, Mauritania, Mozambique, Nepal, Niger, Rwanda, Samoa, Sao Tome and Principe, Senegal, Sierra Leone, Solomon Islands, Somalia, South Sudan, Tanzania, Timor-Leste, Togo, Tuvalu, Uganda, Vanuatu, Yemen, or Zambia); or

(4) A Caribbean Basin country (Antigua and Barbuda, Aruba, Bahamas, Barbados, Belize,

Bonaire, British Virgin Islands, Curacao, Dominica, Grenada, Guyana, Haiti, Jamaica, Montserrat, Saba, St. Kitts and Nevis, St. Lucia, St. Vincent and the Grenadines, Sint Eustatius, Sint Maarten, or Trinidad and Tobago).

Designated country construction material means a construction material that is a WTO GPA country construction material, an FTA country construction material, a least developed country construction material, or a Caribbean Basin country construction material.

Domestic construction material means-

(1) For construction material that does not consist wholly or predominantly of iron or steel or a combination of both-

(i) An unmanufactured construction material mined or produced in the United States; or

(ii) A construction material manufactured in the United States, if-

(A) The cost of its components mined, produced, or manufactured in the United States exceeds 60 percent of the cost of all its components, except that the percentage will be 65 percent for items delivered in calendar years 2024 through 2028 and 75 percent for items delivered starting in calendar year 2029. Components of foreign origin of the same class or kind for which nonavailability determinations have been made are treated as domestic. Components of unknown origin are treated as foreign; or

(B) The construction material is a COTS item; or

(2) For construction material that consists wholly or predominantly of iron or steel or a combination of both, a construction material manufactured in the United States if the cost of foreign iron and steel constitutes less than 5 percent of the cost of all components used in such construction material. The cost of foreign iron and steel includes but is not limited to the cost of foreign iron or steel mill products (such as bar, billet, slab, wire, plate, or sheet), castings, or forgings utilized in the manufacture of the construction material and a good faith estimate of the cost of all foreign iron or steel components excluding COTS fasteners. Iron or steel components of unknown origin are treated as foreign. If the construction material contains multiple components, the cost of all the materials used in such construction material is calculated in accordance with the definition of "cost of components".

Fastener means a hardware device that mechanically joins or affixes two or more objects together. Examples of fasteners are nuts, bolts, pins, rivets, nails, clips, and screws.

Foreign construction material means a construction material other than a domestic construction material.

Foreign iron and steel means iron or steel products not produced in the United States. Produced in the United States means that all manufacturing processes of the iron or steel must take place in the United States, from the initial melting stage through the application of coatings, except metallurgical processes involving refinement of steel additives. The origin of the elements of the iron or steel is not relevant to the determination of whether it is domestic or foreign.

Free Trade Agreement country construction material means a construction material that-

(1) Is wholly the growth, product, or manufacture of a Free Trade Agreement (FTA) country; or

(2) In the case of a construction material that consists in whole or in part of materials from another country, has been substantially transformed in a FTA country into a new and different construction material distinct from the materials from which it was transformed.

Least developed country construction material means a construction material that-

(1) Is wholly the growth, product, or manufacture of a least developed country; or

(2) In the case of a construction material that consists in whole or in part of materials from another country, has been substantially transformed in a least developed country into a new and different construction material distinct from the materials from which it was transformed.

Predominantly of iron or steel or a combination of both means that the cost of the iron and steel content exceeds 50 percent of the total cost of all its components. The cost of iron and steel is the cost of the iron or steel mill products (such as bar, billet, slab, wire, plate, or sheet), castings, or forgings utilized in the manufacture of the product and a good faith estimate of the cost of iron or steel components excluding COTS fasteners.

Steel means an alloy that includes at least 50 percent iron, between 0.02 and 2 percent carbon, and may include other elements.

United States means the 50 States, the District of Columbia, and outlying areas.

WTO GPA country construction material means a construction material that-

(1) Is wholly the growth, product, or manufacture of a WTO GPA country; or

(2) In the case of a construction material that consists in whole or in part of materials from another country, has been substantially transformed in a WTO GPA country into a new and

different construction material distinct from the materials from which it was transformed.

(b) Construction materials.

(1) This clause implements 41 U.S.C. chapter 83, Buy American, by providing a preference for domestic construction material. In accordance with 41 U.S.C.1907, the domestic content test of the Buy American statute is waived for construction material that is a COTS item, except that for construction material that consists wholly or predominantly of iron or steel or a combination of both, the domestic content test is applied only to the iron and steel content of the construction material, excluding COTS fasteners. In addition, the Contracting Officer has determined that the WTO GPA and Free Trade Agreements (FTAs) apply to this acquisition. Therefore, the Buy American restrictions are waived for designated country construction materials.

(2) The Contractor shall use only domestic or designated country construction material in performing this contract, except as provided in paragraphs (b)(3) and (b)(4) of this clause.

(3) The requirement in paragraph (b)(2) of this clause does not apply to information technology that is a commercial product or to the construction materials or components listed by the Government as follows:

_____ [Contracting Officer is to list applicable excepted materials or indicate "none"]

(4) The Contracting Officer may add other foreign construction material to the list in paragraph (b)(3) of this clause if the Government determines that-

(i) The cost of domestic construction material would be unreasonable.

(A) For domestic construction material that is not a critical item or does not contain critical components.

(1) The cost of a particular domestic construction material subject to the restrictions of the Buy American statute is unreasonable when the cost of such material exceeds the cost of foreign material by more than 20 percent;

(2) [Reserved]

(3) [Reserved]

(B) For domestic construction material that is a critical item or contains critical components.

(1) The cost of a particular domestic construction material that is a critical item or contains

critical components, subject to the requirements of the Buy American statute, is unreasonable when the cost of such material exceeds the cost of foreign material by more than 20 percent plus the additional preference factor identified for the critical item or construction material containing critical components listed at FAR 25.105.

(2) [Reserved]

(3) [Reserved]

(ii) The application of the restriction of the Buy American statute to a particular construction material would be impracticable or inconsistent with the public interest; or

(iii) The construction material is not mined, produced, or manufactured in the United States in sufficient and reasonably available commercial quantities of a satisfactory quality.

(c) Request for determination of inapplicability of the Buy American statute.

(1)

(i) Any Contractor request to use foreign construction material in accordance with paragraph (b)(4) of this clause shall include adequate information for Government evaluation of the request, including-

(A) A description of the foreign and domestic construction materials;

(B) Unit of measure;

(C) Quantity;

(D) Price;

(E) Time of delivery or availability;

(F) Location of the construction project;

(G) Name and address of the proposed supplier; and

(H) A detailed justification of the reason for use of foreign construction materials cited in accordance with paragraph (b)(3) of this clause.

(ii) A request based on unreasonable cost shall include a reasonable survey of the market and a completed price comparison table in the format in paragraph (d) of this clause.

(iii) The price of construction material shall include all delivery costs to the construction site and any applicable duty (whether or not a duty-free certificate may be issued).

(iv) Any Contractor request for a determination submitted after contract award shall explain why the Contractor could not reasonably foresee the need for such determination and could not have requested the determination before contract award. If the Contractor does not submit a satisfactory explanation, the Contracting Officer need not make a determination.

(2) If the Government determines after contract award that an exception to the Buy American statute applies and the Contracting Officer and the Contractor negotiate adequate consideration, the Contracting Officer will modify the contract to allow use of the foreign construction material. However, when the basis for the exception is the unreasonable price of a domestic construction material, adequate consideration is not less than the differential established in paragraph (b)(4)(i) of this clause.

(3) Unless the Government determines that an exception to the Buy American statute applies, use of foreign construction material is noncompliant with the Buy American statute.

(d) Data. To permit evaluation of requests under paragraph (c) of this clause based on unreasonable cost, the Contractor shall include the following information and any applicable supporting data based on the survey of suppliers:

Foreign and Domestic Construction Materials Price Comparison			
Quantity	Construction material description	Unit of measure	
	Price (dollars)*		
	Item 1:		
	Foreign construction material.	_____	_____
	Domestic construction material.	_____	_____
	Item 2:		
	Foreign construction material.	_____	_____
	Domestic construction material.	_____	_____

[* Include all delivery costs to the construction site and any applicable duty (whether or not a duty-free entry certificate is issued)].

[List name, address, telephone number, and contact for suppliers surveyed. Attach copy of response; if oral, attach summary.]

[Include other applicable supporting information.]

(End of clause)

52.228-15	Performance and Payment Bonds- Construction (Deviation 2020-O0016)	2020-06	Deviation 2020- O0016	2020-04
-----------	---	---------	-----------------------------	---------

PERFORMANCE AND PAYMENT BONDS-CONSTRUCTION (APR 2020) (DEVIATION 2020-O0016)

(a) Definitions. As used in this clause-

Original contract price means the award price of the contract; or, for requirements contracts, the price payable for the estimated total quantity; or, for indefinite-quantity contracts, the price payable for the specified minimum quantity. Original contract price does not include the price of any options, except those options exercised at the time of contract award.

(b) Amount of required bonds. Unless the resulting contract price is \$150,000 or less, the successful offeror shall furnish performance and payment bonds to the Contracting Officer as follows:

(1) Performance bonds (Standard Form 25, except that no seal is required). The penal amount of performance bonds at the time of contract award shall be 100 percent of the original contract price.

(2) Payment bonds (Standard Form 25A, except that no seal is required). The penal amount of payment bonds at the time of contract award shall be 100 percent of the original contract price.

(3) Additional bond protection.

(i) The Government may require additional performance and payment bond protection if the contract price is increased. The increase in protection generally will equal 100 percent of the increase in contract price.

(ii) The Government may secure the additional protection by directing the Contractor to increase the penal amount of the existing bond or to obtain an additional bond.

(c) Furnishing executed bonds. The Contractor shall furnish all executed bonds, including

(ii) A listing of the amount included for work performed by each subcontractor under the contract.

(iii) A listing of the total amount of each subcontract under the contract.

(iv) A listing of the amounts previously paid to each such subcontractor under the contract.

(v) Additional supporting data in a form and detail required by the Contracting Officer.

(2) In the preparation of estimates, the Contracting Officer may authorize material delivered on the site and preparatory work done to be taken into consideration. Material delivered to the Contractor at locations other than the site also may be taken into consideration if-

(i) Consideration is specifically authorized by this contract; and

(ii) The Contractor furnishes satisfactory evidence that it has acquired title to such material and that the material will be used to perform this contract.

(c) Contractor certification. Along with each request for progress payments, the Contractor shall furnish the following certification, or payment shall not be made: (However, if the Contractor elects to delete paragraph (c)(4) from the certification, the certification is still acceptable.)

I hereby certify, to the best of my knowledge and belief, that-

(1) The amounts requested are only for performance in accordance with the specifications, terms, and conditions of the contract;

(2) All payments due to subcontractors and suppliers from previous payments received under the contract have been made, and timely payments will be made from the proceeds of the payment covered by this certification, in accordance with subcontract agreements and the requirements of Chapter 39 of Title 31, United States Code;

(3) This request for progress payments does not include any amounts which the prime contractor intends to withhold or retain from a subcontractor or supplier in accordance with the terms and conditions of the subcontract; and

(4) This certification is not to be construed as final acceptance of a subcontractor's performance.

_____(Name)

_____(Title)

_____(Date)

(d) Refund of unearned amounts. If the Contractor, after making a certified request for progress payments, discovers that a portion or all of such request constitutes a payment for performance by the Contractor that fails to conform to the specifications, terms, and conditions of this contract (hereinafter referred to as the "unearned amount"), the Contractor shall-

(1) Notify the Contracting Officer of such performance deficiency; and

(2) Be obligated to pay the Government an amount (computed by the Contracting Officer in the manner provided in paragraph (j) of this clause) equal to interest on the unearned amount from the 8 thday after the date of receipt of the unearned amount until-

(i) The date the Contractor notifies the Contracting Officer that the performance deficiency has been corrected; or

(ii) The date the Contractor reduces the amount of any subsequent certified request for progress payments by an amount equal to the unearned amount.

(e) Retainage. If the Contracting Officer finds that satisfactory progress was achieved during any period for which a progress payment is to be made, the Contracting Officer shall authorize payment to be made in full. However, if satisfactory progress has not been made, the Contracting Officer may retain a maximum of 10 percent of the amount of the payment until satisfactory progress is achieved. When the work is substantially complete, the Contracting Officer may retain from previously withheld funds and future progress payments that amount the Contracting Officer considers adequate for protection of the Government and shall release to the Contractor all the remaining withheld funds. Also, on completion and acceptance of each separate building, public work, or other division of the contract, for which the price is stated separately in the contract, payment shall be made for the completed work without retention of a percentage.

(f) Title, liability, and reservation of rights. All material and work covered by progress payments made shall, at the time of payment, become the sole property of the Government, but this shall not be construed as-

(1) Relieving the Contractor from the sole responsibility for all material and work upon which payments have been made or the restoration of any damaged work; or

(2) Waiving the right of the Government to require the fulfillment of all of the terms of the contract.

(g) Reimbursement for bond premiums. In making these progress payments, the Government shall, upon request, reimburse the Contractor for the amount of premiums paid for performance and payment bonds (including coinsurance and reinsurance agreements, when applicable) after the Contractor has furnished evidence of full payment to the surety. The retainage provisions in paragraph (e) of this clause shall not apply to that portion of progress payments attributable to bond premiums.

(h) Final payment. The Government shall pay the amount due the Contractor under this contract after-

(1) Completion and acceptance of all work;

(2) Presentation of a properly executed voucher; and

(3) Presentation of release of all claims against the Government arising by virtue of this contract, other than claims, in stated amounts, that the Contractor has specifically excepted from the operation of the release. A release may also be required of the assignee if the Contractor's claim to amounts payable under this contract has been assigned under the Assignment of Claims Act of 1940 (31 U.S.C.3727 and 41 U.S.C.6305).

(i) Limitation because of undefinitized work. Notwithstanding any provision of this contract, progress payments shall not exceed 80 percent on work accomplished on undefinitized contract actions. A "contract action" is any action resulting in a contract, as defined in FAR subpart 2.1, including contract modifications for additional supplies or services, but not including contract modifications that are within the scope and under the terms of the contract, such as contract modifications issued pursuant to the Changes clause, or funding and other administrative changes.

(j) Interest computation on unearned amounts. In accordance with 31 U.S.C.3903(c)(1), the amount payable under paragraph (d)(2) of this clause shall be-

(1) Computed at the rate of average bond equivalent rates of 91-day Treasury bills auctioned at the most recent auction of such bills prior to the date the Contractor receives the unearned amount; and

(2) Deducted from the next available payment to the Contractor.

(End of clause)

52.248-3 Value Engineering-Construction. 2025-10

Value Engineering-Construction (Oct 2025)

(a) General. The Contractor is encouraged to develop, prepare, and submit value engineering change proposals (VECP's) voluntarily. The Contractor shall share in any instant contract savings realized from accepted VECP's, in accordance with paragraph (f) of this clause.

(b) Definitions. "Collateral costs," as used in this clause, means agency costs of operation, maintenance, logistic support, or Government-furnished property.

Collateral savings, as used in this clause, means those measurable net reductions resulting from a VECP in the agency's overall projected collateral costs, exclusive of acquisition savings, whether or not the acquisition cost changes.

Contractor's development and implementation costs, as used in this clause, means those costs the Contractor incurs on a VECP specifically in developing, testing, preparing, and submitting the VECP, as well as those costs the Contractor incurs to make the contractual changes required by Government acceptance of a VECP.

Government costs, as used in this clause, means those agency costs that result directly from developing and implementing the VECP, such as any net increases in the cost of testing, operations, maintenance, and logistic support. The term does not include the normal administrative costs of processing the VECP.

Instant contract savings, as used in this clause, means the estimated reduction in Contractor cost of performance resulting from acceptance of the VECP, minus allowable Contractor's development and implementation costs, including subcontractors' development and implementation costs (see paragraph (h) of this clause).

Value engineering change proposal (VECP) means a proposal that-

- (1) Requires a change to this, the instant contract, to implement; and
- (2) Results in reducing the contract price or estimated cost without impairing essential

functions or characteristics; provided, that it does not involve a change-

(i) In deliverable end item quantities only; or

(ii) To the contract type only.

(c) VECF preparation. As a minimum, the Contractor shall include in each VECF the information described in paragraphs (c)(1) through (7) of this clause. If the proposed change is affected by contractually required configuration management or similar procedures, the instructions in those procedures relating to format, identification, and priority assignment shall govern VECF preparation. The VECF shall include the following:

(1) A description of the difference between the existing contract requirement and that proposed, the comparative advantages and disadvantages of each, a justification when an item's function or characteristics are being altered, and the effect of the change on the end item's performance.

(2) A list and analysis of the contract requirements that must be changed if the VECF is accepted, including any suggested specification revisions.

(3) A separate, detailed cost estimate for (i) the affected portions of the existing contract requirement and (ii) the VECF. The cost reduction associated with the VECF shall take into account the Contractor's allowable development and implementation costs, including any amount attributable to subcontracts under paragraph (h) of this clause.

(4) A description and estimate of costs the Government may incur in implementing the VECF, such as test and evaluation and operating and support costs.

(5) A prediction of any effects the proposed change would have on collateral costs to the agency.

(6) A statement of the time by which a contract modification accepting the VECF must be issued in order to achieve the maximum cost reduction, noting any effect on the contract completion time or delivery schedule.

(7) Identification of any previous submissions of the VECF, including the dates submitted, the agencies and contract numbers involved, and previous Government actions, if known.

(d) Submission. The Contractor shall submit VECF's to the Resident Engineer at the worksite, with a copy to the Contracting Officer.

(e) Government action.

(1) The Contracting Officer will notify the Contractor of the status of the VECP within 45 calendar days after the contracting office receives it. If additional time is required, the Contracting Officer will notify the Contractor within the 45-day period and provide the reason for the delay and the expected date of the decision. The Government will process VECP's expeditiously; however, it will not be liable for any delay in acting upon a VECP.

(2) If the VECP is not accepted, the Contracting Officer will notify the Contractor in writing, explaining the reasons for rejection. The Contractor may withdraw any VECP, in whole or in part, at any time before it is accepted by the Government. The Contracting Officer may require that the Contractor provide written notification before undertaking significant expenditures for VECP effort.

(3) Any VECP may be accepted, in whole or in part, by the Contracting Officer's award of a modification to this contract citing this clause. The Contracting Officer may accept the VECP, even though an agreement on price reduction has not been reached, by issuing the Contractor a notice to proceed with the change. Until a notice to proceed is issued or a contract modification applies a VECP to this contract, the Contractor shall perform in accordance with the existing contract. The decision to accept or reject all or part of any VECP is a unilateral decision made solely at the discretion of the Contracting Officer.

(f) Sharing-

(1) Rates. The Government's share of savings is determined by subtracting Government costs from instant contract savings and multiplying the result by-

(i) 45 percent for fixed-price contracts; or

(ii) 75 percent for cost-reimbursement contracts.

(2) Payment. Payment of any share due the Contractor for use of a VECP on this contract shall be authorized by a modification to this contract to-

(i) Accept the VECP;

(ii) Reduce the contract price or estimated cost by the amount of instant contract savings; and

(iii) Provide the Contractor's share of savings by adding the amount calculated to the contract price or fee.

(g) Collateral savings. If a VECP is accepted, the Contracting Officer will increase the instant contract amount by 20 percent of any projected collateral savings determined to be realized in a typical year of use after subtracting any Government costs not previously offset. However, the Contractor's share of collateral savings will not exceed the contract's firm-fixed-price or estimated cost, at the time the VECP is accepted, or \$100,000, whichever is greater. The Contracting Officer is the sole determiner of the amount of collateral savings.

(h) Subcontracts. The Contractor shall include an appropriate value engineering clause in any subcontract of \$90,000 or more and may include one in subcontracts of lesser value. In computing any adjustment in this contract's price under paragraph (f) of this clause, the Contractor's allowable development and implementation costs shall include any subcontractor's allowable development and implementation costs clearly resulting from a VECP accepted by the Government under this contract, but shall exclude any value engineering incentive payments to a subcontractor. The Contractor may choose any arrangement for subcontractor value engineering incentive payments; provided, that these payments shall not reduce the Government's share of the savings resulting from the VECP.

(i) Data. The Contractor may restrict the Government's right to use any part of a VECP or the supporting data by marking the following legend on the affected parts:

These data, furnished under the Value Engineering-Construction clause of contract _____, shall not be disclosed outside the Government or duplicated, used, or disclosed, in whole or in part, for any purpose other than to evaluate a value engineering change proposal submitted under the clause. This restriction does not limit the Government's right to use information contained in these data if it has been obtained or is otherwise available from the Contractor or from another source without limitations.

If a VECP is accepted, the Contractor hereby grants the Government unlimited rights in the VECP and supporting data, except that, with respect to data qualifying and submitted as limited rights technical data, the Government shall have the rights specified in the contract modification implementing the VECP and shall appropriately mark the data. (The terms "unlimited rights" and "limited rights" are defined in part 27 of the Federal Acquisition Regulation.)

(End of clause)

52.252-2 Clauses Incorporated by Reference. 1998-02

Clauses Incorporated By Reference (Feb 1998)

This contract incorporates one or more clauses by reference, with the same force and effect as if they were given in full text. Upon request, the Contracting Officer will make their full text available. Also, the full text of a clause may be accessed electronically at this/these address (es):

www.acquisition.gov

(End of clause)

52.252-4 Alterations in Contract. 1984-04

Alterations in Contract (Apr 1984)

Portions of this contract are altered as follows:

(End of clause)

52.252-6 Authorized Deviations in Clauses. 2020-11

Authorized Deviations in Clauses (Nov 2020)

(a) The use in this solicitation or contract of any Federal Acquisition Regulation (48 CFR Chapter 1) clause with an authorized deviation is indicated by the addition of "(DEVIATION)" after the date of the clause.

(b) The use in this solicitation or contract of any DFARS (48 CFR Chapter 2) clause with an authorized deviation is indicated by the addition of "(DEVIATION)" after the name of the regulation.

(End of clause)

DFARS Clauses Incorporated by Full Text

Number	Title	Effective Date	Alternate Deviation	Variation Effective Date
252.204-7021	Contractor Compliance with the Cybersecurity Maturity Model Certification Level Requirements.	2025-11		

CONTRACTOR COMPLIANCE WITH THE CYBERSECURITY MATURITY MODEL CERTIFICATION LEVEL REQUIREMENTS (NOV 2025)

(a) Definitions. As used in this clause-

"Controlled unclassified information" means information the Government creates or possesses, or information an entity creates or possesses for or on behalf of the Government, that a law, regulation, or Governmentwide policy requires or permits an agency to handle using safeguarding or dissemination controls (32 CFR 2002.4(h)).

"Current" means-

(1) With regard to Conditional Cybersecurity Maturity Model Certification (CMMC) Status-

(i) Not older than 180 days for Conditional Level 2 (Self) assessments and Conditional Level 2 (certified third-party assessment organization (C3PAO)) assessments, with-

(A) No changes in compliance with the requirements at 32 CFR part 170 since the Conditional CMMC Status date (see 32 CFR 170.16 and 170.17); and

(B) A corresponding affirmation of continuous compliance by an affirming official (see 32 CFR 170.4); and

(ii) Not older than 180 days for Conditional Level 3 (Defense Industrial Base Cybersecurity Assessment Center (DIBCAC)) assessments, with-

(A) No changes in compliance with the requirements at 32 CFR part 170 since the Conditional CMMC Status date (see 32 CFR 170.18); and

(B) A corresponding affirmation of continuous compliance by an affirming official;

(2) With regard to Final CMMC Status-

(i) Not older than 1 year for Final Level 1 (Self), with-

(A) No changes in compliance with the requirements at 32 CFR part 170 since the Final CMMC Status date (see 32 CFR 170.15); and

(B) A corresponding affirmation of continuous compliance, not older than 1 year, by an affirming official;

(ii) Not older than 3 years for Final Level 2 (Self) assessments and Final Level 2 (C3PAO) assessments, with-

(A) No changes in compliance with the requirements at 32 CFR part 170 since the Final CMMC Status date (see 32 CFR 170.16 and 170.17); and

(B) A corresponding affirmation of continuous compliance, not older than 1 year, by an affirming official; and

(iii) Not older than 3 years for Final Level 3 (DIBCAC) assessments, with-

(A) No changes in compliance with the requirements at 32 CFR part 170 since the Final CMMC Status date (see 32 CFR 170.18); and

(B) A corresponding affirmation of continuous compliance, not older than 1 year, by an affirming official; and

(3) With regard to affirmation of continuous compliance (32 CFR 170.22), not older than 1 year with no changes in compliance with the requirements at 32 CFR part 170.

"Cybersecurity Maturity Model Certification (CMMC) status" means the result of meeting or exceeding the minimum required score for the corresponding assessment. The potential statuses are as follows:

(1) Final Level 1 (Self).

(2) Conditional Level 2 (Self).

(3) Final Level 2 (Self).

(4) Conditional Level 2 (C3PAO).

(5) Final Level 2 (C3PAO).

(6) Conditional Level 3 (DIBCAC).

(7) Final Level 3 (DIBCAC).

"Cybersecurity Maturity Model Certification unique identifier (CMMC UID)" means 10 alphanumeric characters assigned to each CMMC assessment and reflected in the Supplier Performance Risk System (SPRS) for each contractor information system.

"Federal contract information (FCI)" means information, not intended for public release, that is provided by or generated for the Government under a contract to develop or deliver a product or service to the Government. It does not include information provided by the Government to the public, such as on public websites, or simple transactional information, such as information necessary to process payments.

"Plan of action and milestones" means a document that identifies tasks to be accomplished. It details resources required to accomplish the elements of the plan, any milestones in meeting the tasks, and scheduled completion dates for the milestones, as defined in National Institute of Standards and Technology Special Publication 800-115 (32 CFR 170.21).

(b) Framework. The Cybersecurity Maturity Model Certification (CMMC) is a framework for assessing a contractor's compliance with applicable information security protections (see 32 CFR part 170).

(c) Duplication. The CMMC assessments will not duplicate efforts from any other comparable DoD assessment, except for rare circumstances when a reassessment may be necessary, for example, when there are indications of issues with cybersecurity and/or compliance with CMMC requirements.

(d) Requirements. The Contractor shall-

(1)(i) Have and maintain for the duration of the contract a current CMMC status at the following CMMC level, or higher: _____ Contracting Officer insert: CMMC Level 1 (Self); CMMC Level 2 (Self); CMMC Level 2 (C3PAO); or CMMC Level 3 (DIBCAC) for all information systems used in performance of the contract, task order, or delivery order that process, store, or transmit FCI or CUI; and

(ii) Consult 32 CFR 170.23 related to the flowdown of the CMMC requirements, and flow down the correct CMMC level to subcontracts and other contractual instruments;

(2) Only process, store, or transmit FCI or CUI on contractor information systems that have a CMMC status at the CMMC level required in paragraph (d)(1) of this clause, or higher;

(3) Complete on an annual basis, and maintain as current, an affirmation, by the affirming official (see 32 CFR 170.4), of continuous compliance with the requirements associated with the CMMC level required in paragraph (d)(1) of this clause in the Supplier Performance Risk System (SPRS) (<https://piee.eb.mil>) for each CMMC UID applicable to each of the contractor information systems that process, store, or transmit FCI or CUI and that are used in performance of the contract;

(4) Ensure all subcontractors and suppliers complete prior to subcontract award, and maintain on an annual basis, an affirmation, by the affirming official (see 32 CFR 170.4), of continuous compliance with the requirements associated with the CMMC level required for the subcontract or other contractual instrument for each of the subcontractor information systems that process, store, or transmit FCI or CUI and that are used in performance of the subcontract; and

(5) If the Contractor has a CMMC Status of Conditional, successfully close out a valid plan of action and milestones (32 CFR 170.21) to achieve a CMMC Status of Final.

(e) Reporting. The Contractor shall-

(1) Submit to the Contracting Officer-

(i) The CMMC UID(s) issued by SPRS for contractor information systems that will process, store, or transmit FCI or CUI during performance of the contract; and

(ii) Any changes in the CMMC UIDs generated in SPRS throughout the life of the contract, task order, or delivery order, if applicable;

(2) Enter into SPRS the results of a current self-assessment for each CMMC UID, not covered by a C3PAO assessment or DIBCAC assessment, applicable to each of the contractor information systems that process, store, or transmit FCI or CUI and that are used in performance of the contract; and

(3) Complete in SPRS on an annual basis and maintain as current an affirmation of continuous compliance by the affirming official (see 32 CFR 170.4) for each self-assessment, C3PAO assessment, or DIBCAC assessment required under the contract in SPRS.

(f) Subcontracts. The Contractor shall-

(1) Insert the substance of this clause, including this paragraph (f) and excluding paragraph (e)(1), in subcontracts and other contractual instruments, including those for the acquisition of commercial products or commercial services, excluding commercially available off-the-shelf items, if the subcontract or other contractual instrument will contain a requirement to process, store, or transmit FCI or CUI; and

(2) Prior to awarding a subcontract or other contractual instrument, ensure that the subcontractor has a current CMMC certificate or current CMMC status at the CMMC level that is appropriate for the information that is being flowed down to the subcontractor based on the requirements at 32 CFR 170.23.

(End of clause)

252.236-7001 Contract Drawings and Specifications. 2000-08

CONTRACT DRAWINGS AND SPECIFICATIONS (AUG 2000)

(a) The Government will provide to the Contractor, without charge, one set of contract drawings and specifications, except publications incorporated into the technical provisions by reference, in electronic or paper media as chosen by the Contracting Officer.

(b) The Contractor shall-

(1) Check all drawings furnished immediately upon receipt;

(2) Compare all drawings and verify the figures before laying out the work;

(3) Promptly notify the Contracting Officer of any discrepancies;

(4) Be responsible for any errors that might have been avoided by complying with this paragraph (b); and

(5) Reproduce and print contract drawings and specifications as needed.

(c) In general--

(1) Large-scale drawings shall govern small-scale drawings; and

(2) The Contractor shall follow figures marked on drawings in preference to scale measurements.

(d) Omissions from the drawings or specifications or the misdescription of details of work that are manifestly necessary to carry out the intent of the drawings and specifications, or that are customarily performed, shall not relieve the Contractor from performing such omitted or misdescribed details of the work. The Contractor shall perform such details as if fully and correctly set forth and described in the drawings and specifications.

(e) The work shall conform to the specifications and the contract drawings identified on the following index of drawings:

Title	File	Drawing No.
_____	_____	_____
_____	_____	_____
_____	_____	_____
_____	_____	_____
_____	_____	_____

(End of clause)

SECTION 01 00 00

ADDITIONAL SPECIAL CONTRACT REQUIREMENTS
EGLIN AFB

PART 1 GENERAL

Amendment 0001

1.1 COMMENCEMENT, PROSECUTION, AND COMPLETION OF WORK

The Contractor shall be required to (1) commence work under this contract within 8 calendar days after the date the Contractor receives Notice To Proceed (NTP), (2) prosecute the work diligently, and (3) complete the entire work ready for use not later than 600 ~~547~~ calendar days after receipt of Notice To Proceed (NTP). This time stated for completion shall include final cleanup of the premises. Provisions stipulated for planting and maintenance of grass are excluded from the completion time.

Amendment 0001

1.2 LIQUIDATED DAMAGES - CONSTRUCTION

(a) If the Contractor fails to complete the work within the time specified in the contract, or any extension, the Contractor shall pay to the Government as liquidated damages, the sum of \$1,082.00 for each calendar day of delay.

(b) If the Government terminates the Contractor's right to proceed, the resulting damage will consist of liquidated damages until such reasonable time as may be required for final completion of the work together with any increased costs occasioned the Government in completing the work.

(c) If the Government does not terminate the Contractor's right to proceed, the resulting damage will consist of liquidated damages until the work is completed or accepted.

1.3 SUBMITTALS

Government approval is required for submittals with a "G" designation; submittals not having a "G" designation are for information only. When used, a designation following the "G" designation identifies the office that will review the submittal for the Government. The following shall be submitted in accordance with Section 01 33 00 SUBMITTAL PROCEDURES:

SD-01 Preconstruction Submittals

Hazard Analysis; G, RO

AF Form 103, Base Civil Engineering Work Clearance Request; G, RO

Contractor's Area Use Plan; G, RO.

SD-07 Certificates

Asbestos and Lead Based Paint Certification Letter; G, RO

SD-11 Closeout Submittals

Redlined As-Built Drawings; G, RO

Progress As-Built Building Information Model (BIM); G, RO

Final As-Built BIM; G, RO

As-Built Drawings; G, RO

1.4 JOINT OCCUPANCY

The Contractor is hereby made aware that Joint Occupancy will be required for 90 calendar days prior to the construction completion date for example: "to allow the installation of the following Government Furnished/Government Installed (GFGI) systems and equipment by Base personnel and other Contractors; intrusion detection system (IDS), and access control system (ACS). Contractor shall cooperate to enable the GFGI work to be installed during the construction contract duration."

Amendment 0003

1.5 NOT USED ~~GOVERNMENT FIELD OFFICE~~

~~FOR EXAMPLE: The contractor shall provide an on the jobsite temporary office facility with appropriate square footage and useful floor area for the exclusive use of #### (#) USACE personnel. Provide a weathertight structure with adequate heating and cooling, toilet facilities, lighting and ventilation. Provide an exterior door with a cylinder lock and windows with locking hardware. Contractor shall provide temporary utility services (water, electricity and sewage), as required. Within the USACE Field Office, provide four private offices, approximately 200 square feet in floor area. Include a standard size office desk and chair, 4 by 8 foot table, one visitor chair, and one file cabinet in each private office. Within the remaining office facility, provide two 4 by 8 foot plan table with 14 chairs and 2 file cabinets. At completion of the project, the office will remain the property of the Contractor and be removed from the site. Utilities will be connected and disconnected in accordance with local codes and to the satisfaction of the Contracting Officer.~~

Amendment 0003

1.6 CONTRACTOR RESPONSIBILITY

The Contractor is responsible for the construction of all work. In order to ensure quality, the Contractor shall develop a Quality Control Plan in accordance with Section: 01 45 00 QUALITY CONTROL. In order to allow the Government to monitor the Contractor's progress and review his work, the Contractor shall develop a submittal register as specified in Section: 01 33 00 SUBMITTAL PROCEDURES.

1.7 FACTORY EQUIPMENT TESTS

All pieces of equipment that require factory testing will be witnessed by the Contracting Officer representative (COR). The Contractor shall notify

the COR prior to any tests.

1.8 CONTRACT DRAWINGS, MAPS AND SPECIFICATIONS

a) The Contractor will be furnished on CD ROM/DVD one electronic set of: a reproducible set of the advertised solicitation, including contract clauses, plans, and specifications; solicitation drawing and model file(s); and all amendments. The work shall conform to the specifications and the contract drawings listed in the technical provisions. The solicitation drawings serve as the Contract Documents that such functions shall be based upon.

b) The building design was developed using Autodesk Revit and civil/sitework design was developed using AutoCAD Civil 3D. The Government BIM model was utilized to develop the contract drawings. Model elements were generally developed to a minimum "Level of Development 200" which is defined as "graphically represented within the BIM as a system, object, or assembly in terms of quantity, size, shape, location, and orientation. Non-Graphic information may also be attached to the model elements." Level of Development may vary slightly for some elements. The model elements were developed using the basis of design systems and do not reflect actual systems that were selected, procured, and installed by the Contractor. The models were the Government's instruments of service and as such no guarantee or warranty is provided as to the accuracy or level of development contained therein. The Government furnished BIM model shall not be utilized for shop drawings, fabrication, coordination studies, layout or relied upon or utilized for any other design or construction related purposes. The site and facility shall be constructed as required by the contract documents; 2D drawings and specifications.

c) Omissions from the drawings or specifications, the mis-description of details of work which are manifestly necessary to carry out the intent of the drawings and specifications which are customarily performed shall not relieve the Contractor from performing such omitted or mis-described details of the work but they shall be performed as if fully and correctly set forth and described in the drawings and specifications.

d) The Contractor shall check all drawings furnished him immediately upon their receipt and shall promptly notify the Contracting Officer's Representative of any discrepancies. Figures marked on drawings shall in general be followed in preference to scale measurements. Large scale drawings shall in general govern small scale drawings. The Contractor shall compare all drawings and verify the figures before laying out the work and will be responsible for any errors which might have been avoided thereby.

e) The drawings and maps for this solicitation are hereby incorporated by reference into these specifications. Any schedules included in the drawings are for the purpose of defining requirements other than quantities.

1.9 HAZARD ANALYSIS

A hazard analysis plan, as described in Section 1, Article 01.A.11 of the Corps of Engineers Safety and Health Requirements Manual, EM 385-1-1, latest edition, is required for this contract and shall be submitted

within ten (10) days after Notice To Proceed (NTP).

1.10 PHYSICAL DATA

a. Data and information furnished or referred to below is for the Contractor's information. The Government shall not be responsible for any interpretation of or conclusion drawn from the data or information by the Contractor.

(1) The indications of physical conditions on the drawings and in the specifications are the result of site investigations by surveys.

(2) Weather Conditions. The location is subject to atmospheric temperature ranging from plus 7 degrees to plus 103 degrees Fahrenheit as determined from the U.S. Weather Bureau Station at Pensacola, Florida. The mean annual precipitation at Niceville, Florida is 58.85 inches and the mean monthly precipitation varies from a low of 3.12 inches in May to a high of 8.05 inches in July.

(3) Transportation facilities.

(a) Railroads. The Seaboard System Railroad and the Burlington Northern Railroad serve Pensacola, Florida, the nearest railhead. The Contractor shall investigate the availability of sidings, and shall make all arrangements for use of any sidings for the delivery of any materials and equipment to be used on the work.

(b) Highways. The site is served by U.S. Highway 85. Highway 85 connects the City of Crestview, Interstate 10, and finally the City of Fort Walton Beach. U.S. Highway No. 98 connects Pensacola and Fort Walton Beach, Florida, and runs along the mainland adjacent and parallel to Santa Rosa Island. The site of the work is accessible from Crestview and Fort Walton Beach by bridge and paved road. The Contractor shall make his own investigation of available roads for transportation, load limits for bridges and roads, and other conditions affecting the transportation of materials and equipment to the site. Highway 85 is the main north/south corridor for Crestview/Eglin/ Fort Walton Beach. As such, traffic will be extremely heavy between 6:00-8:00 AM, and 4:00 to 6:00 PM. This could delay access to the site during these periods.

(c) Waterways. The Fort Walton Beach, FL. area is served by the Gulf Intracoastal Waterway. If the Contractor desires to use barge transportation for materials shipment, he shall make his own arrangements with commercial concerns for loading/off loading facilities. Government barge facilities at Eglin Air Force Base are not available for Contractor use.

1.11 TIME EXTENSIONS FOR UNUSUALLY SEVERE WEATHER

a. This provision specifies the procedure for determination of time extensions for unusually severe weather in accordance with the contract clause entitled "Default: (Fixed Price Construction)". In order for the Contracting Officer to award a time extension under this clause, the following conditions must be satisfied:

(1) The weather experienced at the project site during the contract period must be found to be unusually severe. Unusually severe weather is defined as hurricanes, floods, tornados, or earthquakes.

(2) The unusually severe weather must actually cause a delay to the completion of the project. The delay must be beyond the control and without the fault or negligence of the Contractor.

(3) The Contractor's progress schedule must reflect completion of the project within the specified contract duration including all weather except that as defined as unusually severe in (a)(1).

b. The following schedule of monthly anticipated adverse weather delays is based on National Oceanic and Atmospheric Administration (NOAA) or similar data for the project location and will constitute the base line for monthly weather time evaluations. The Contractor's progress schedule must reflect these anticipated adverse weather delays in all weather dependent activities.

MONTHLY ANTICIPATED ADVERSE WEATHER DELAY
WORK DAYS BASED ON (5) DAY WORK WEEK

JAN	FEB	MAR	APR	MAY	JUN	JUL	AUG	SEP	OCT	NOV	DEC
5	5	5	3	3	5	8	6	5	3	4	5

c. Upon acknowledgement of the Notice to Proceed and continuing throughout the contract, the Contractor will record on its daily Contractor Quality Control report, the occurrence of adverse weather and resultant impact to normally scheduled work. Actual adverse weather delay days must prevent work on critical activities for 50 percent or more of the Contractor's scheduled work day.

d. The number of actual adverse weather delay days shall include days impacted by actual adverse weather (even if adverse weather occurred in previous month), be calculated chronologically from the first to the last day of each month, and be recorded as full days. If the number of actual adverse weather delay days exceeds the number of days anticipated in paragraph b, above, the Contracting Officer will convert any qualifying delays to calendar days, giving full consideration for equivalent fair weather work days, and issue a modification in accordance with the Contract Clause entitled "Default (Fixed Price Construction)".

1.12 INTERRUPTION OF UTILITY SERVICES

a. Planned interruptions of utility services (electrical power, water, natural gas, etc.) shall be detailed and coordinated by the Contractor. Requests for interruptions shall be submitted in writing by the Contractor to the Contracting Officer's Representative at least 10 (ten) working days before the planned outage. This request shall also be shared with the U.S. Army Corps of Engineers project representative.

Contractor shall not interrupt service(s) until approval has been granted. Requests shall include facility/facilities affected, date of scheduled outage, and duration. Requests for interruption of service(s) will not be approved until all equipment and materials required for that particular phase of work are on the job site. Interruptions will be allowed Monday through Friday for the following times: 7:15 A.M. until 11:00 A.M. and 12:30 P.M. until 4:00 P.M. and will be limited to 4 hours. If weekend (Saturday and Sunday) outages are required or are preferred, they shall be coordinated as specified above and may result in additional charges by the utility provider.

1.13 CONTRACTOR INITIATED ROAD CLOSURES

Planned road closures shall be detailed and coordinated by the Contractor. Requests for road closures shall be submitted in writing by the Contractor to the Contracting Officer's Representative at least 10 (ten) working days before the planned closure. When it becomes necessary to close roads for construction, the Contractor shall immediately put in place the necessary signs and barricades required. All traffic control devices (signs, barricades, pavement markings, traffic signals, intersection control beacons, delineators, etc.) shall conform to the FHWA Manual on Uniform Traffic Control Devices and the FHWA publication Standard Highway Signs, most current edition. These include, but are not limited to, begin/end construction signs, standard traffic control signs, including clearly marked detours and barricades with yellow flashing caution lights. Hand painted plywood signs (or other materials) are not allowed or acceptable. Upon completion of road work, all signs and barricades shall be immediately removed and all normal traffic control devices and signs returned to their original condition. Signs and barricades shall not be left along sides of roadways.

1.14 CONTRACTOR PREPARED AS-BUILT BUILDING INFORMATION MODELING (BIM) AND DRAWINGS

a. Redlined As-Built Drawings: Copies of the drawings will be the responsibility of the Contractor. The as-built drawings shall be a record of the construction as installed and completed by the Contractor. They shall include all the information shown on the contract set of drawings and a record of all deviations, modifications, or changes from those drawings which were incorporated in the work; all additional work not appearing on the contract drawings; and all changes which are made after final inspection of the contract work. In the event the Contractor accomplishes additional work which changes the as-built conditions of the facility after submission of the as-built drawings, the Contractor shall furnish revised and/or additional drawings as required to depict as-built conditions. The requirements for these additional drawings will be the same as for the as-built drawings included in the original submittal.

The Contractor shall have on his staff, personnel to mark up a set of paper copy construction drawings to show the as-built conditions. These as-built marked copies shall be kept current and available on the job site at all times. All changes from the contract plans which are made in the work or additional information which might be uncovered in the course of construction shall be accurately and neatly recorded, as the events occur, by means of details and notes. The Contractor shall call attention to entries by redlining areas affected. The red line as-built will be jointly inspected for accuracy and completeness by the Contracting Officer's representative and a responsible representative of the Contractor prior to submittal of each request for payment. The Contracting Officer's approval of the current status of the as-built drawings shall be a prerequisite to the Contracting Officer's approval of request for progress payment and request for final payment under the contract. The drawings shall show the following information, but not be limited thereto:

(1) The location and description of any utility lines or other installations of any kind or description known to exist within the construction area. The location includes dimensions to permanent features.

(2) The location and dimensions of any changes within the building

or structures.

(3) Correct grade or alignment of roads, structures or utilities if any changes were made from contract plans.

(4) Changes in details of design or additional information obtained from working drawings specified to be prepared and/or furnished by the Contractor including but not limited to fabrication, erection, installation plans and placing details, pipe sizes, insulation material, dimensions of equipment foundations, etc.

(5) All changes or modifications which result from the final inspection.

(6) Options: Where contract drawings or specifications allow options, only the option selected for construction shall be shown on the as-built drawings.

(7) Extensions of Design: Although Fire suppression and fire alarm systems shall be added to the BIM model and subject to all of the submission requirements below (including native file submission on CD-ROM), shop Drawings such as structural fabrication and erection drawings and fire alarm systems that will require extensive redrafting effort in order to create an electronic set will not be required to be incorporated into the electronic set. They will be included as an Appendix to the paper copy set and scanned into .PDF format for inclusion on the same CD-ROM as the other electronically submitted set of drawings.

The Contractor shall participate in monthly review meetings with the Contracting Officer's Representative to show the progress made the preceding month and make all required changes. Prior to final construction inspection, the Contractor shall submit one copy of the red lined as-built drawings to the Contracting Officer's Representative for review and approval. The as-built drawings shall be certified as to their correctness by the signature of an authorized representative of the Contractor.

b. AS-BUILT BIM AND DRAWINGS: During construction, the BIMs (in their native format) shall be updated with the contractor provided extensions of design and changes made during construction. Upon Government approval of the Contractor's redlined copy of the as-built drawings, the revisions indicated on the approved paper set of red-lined construction drawings shall be finalized into the BIMs in addition to 2D AutoCAD drawings. Revise/redraft BIMs and AutoCAD drawings for each solicitation drawing and/or amendment drawing to reflect all changes made during construction as indicated by the approved paper red lined notations on the construction drawings. The information contained with the BIMs and AutoCAD drawings must be consistent.

Revisions/redrafting shall match the font styles, sizes, and formats; line weights/thicknesses and styles/types; and all other drafting elements used on the solicitation drawing/amendments. BIMs and AutoCAD drawings shall be updated per the red-lined construction drawings.

Although the contractor is allowed to independently update the model and drawings, the as-built model shall include all necessary intelligence to produce the as-built construction drawings (including but not limited to accurate plans, elevations, building/wall sections and schedules). Contractor shall utilize the original native BIM applications to generate the as-built models. All submitted BIM Models and associated Facility Data

shall be fully compatible with the originally furnished model and its corresponding version (e.g., Autodesk Revit 2016). Reference files ARE permitted for BIM models to ensure manageable file sizes.

BIM submittals and content shall conform to the following criteria:

U.S. AIR FORCE BUILDING INFORMATION MODELING MINIMUM REQUIREMENTS
VERSION 2.1. Available at:
https://www.wbdg.org/FFC/AF/AFBIM/AF_Minimum_BIM_Requirements_V2.1.pdf.

The following BIM reviews and BIM and drawing submittals are required:

(1) Progress As-Built Building Information Model (BIM): Periodic quality control meetings or construction progress review meetings shall occur, at a minimum, prior to construction of extension of design elements and draft final model submission 60 days prior to construction completion. Submittal requirements include: 3-D interactive visualization from the Model in Navisworks, Adobe 3D PDF 7.0 (or later), Google Earth KMZ or equivalent format; Contractor-certified written report confirming that consistency checks have been completed, and shall include contract change tracking information; and progress updated BIM model(s). At the review meetings, perform a review of the development of the Model components and Facility Data via a 3-D interactive visualization demonstration from the Model to the user, USACE, and BCE personnel using data format of choice. The redlined drawings shall be available at the review meeting for identification of the changes to clearly demonstrate that the as-built changes have been made in the model. Updated drawing files shall be available for review at progress review meeting as well to illustrate conformance with final as-built requirements.

(2) Final As-Built BIM: Submit two (2) sets of electronic copies (CD-ROM/DVD) of the final Model(s) files reflecting as-built conditions for Government Approval. Submittal shall be provided to the Contracting Officer's Representative not later than ten (10) calendar days after project completion date. Final 3-D visualization submittal in Navisworks shall be provided on th CD-ROM/DVD as part of this submittal.

(3) As-Built Drawings: The contractor shall provide 1 hard copy of as-built construction drawings on Mylar on an ANSI D sheet size and 2 CD ROMs in AutoCAD and PDF. Submittals are to be to the Contracting Officer's Representative not later than ten (10) calendar days after project completion date.

The Contractor shall coordinate with the Eglin AFB 96 CEG drafting section, through the COR, for the version of AutoCAD to provide. All elements shall be incorporated into each as-built drawing file; the use of reference files shall not be permitted for DWG sheet files. Scaled drawings shall provide a bar scale and shall be in Imperial units and not metric. The as-built DWG files shall have the Design model physical features such as floor plans and civil site plans in Model Space. Sheet features such as title blocks, notes, north arrows and scale bar will be in the Layout View (Paper Space). In addition, the Contractor shall include the assigned building number issued by Eglin AFB in the title block and AF FTFA number beneath the word "AS-BUILT" on each sheet.

AutoCAD drawings shall have correct geometry. Segmented lines and arcs shall be made continuous and free of self-overlapping sections, thus decreasing the file size and increasing efficiency within the AutoCAD platform. All AutoCAD data shall be free of topological errors such as

slivers, undershoots, overshoots dangles, overlaps, intersections, etc. Area features such as building footprints, parking lots, roadways, and airfield pavements shall be true polyline polygons. Adjacent polygons shall not have gaps or overlaps.

AutoCAD drawings shall be checked for correct spatial projection to one of the following: North American Datum 1983 Florida State Plane North FIPS 0903 Feet (AutoCAD Code FL83-NF) or Universal Transverse Mercator 1984, Zone 16 North (AutoCAD Code UTM84-16N).

Drawings submitted for approval as-builts shall have all changes incorporated into the final drawings. Drawings shall be free of revision clouds, hand-written notes, scanned in change orders, etc. Each sheet shall be annotated in bold letters near the title block with the date the as-builts were accepted (i.e. AS-BUILT DRAWING 12 APR 2012).

The Contractor shall also furnish a revised index of drawings to match the actual design drawings. The drawing title blocks shall be in a uniform format to match the requirements as presented in the solicitation drawings.

A copy of the final contract specifications shall be provided, in PDF format, on final as-built CDs.

c. Payment: Reference Section 01 32 01.00 10 for as-built cost loading requirements. As-built requirements shall include all requirements of this Appendix, to include all drawing files, BIM Models, and Facility Data.

1.15 CONTRACTOR'S AREA USE PLAN

The Contractor shall submit an Area Use Plan to the Contracting Officer's Representative, for approval, within ten (10) days after receipt of Notice to Proceed. The Area Use Plan shall show the following:

- a. Location of Contractor's sheds and trailers.
- b. Location of all Contractor storage areas.
- c. Location of Contractor staging areas.
- d. Temporary utility tie-ins.
- e. Location of Contractor security fencing.
- f. Location of project sign.
- g. Required telephone service and locations.

1.16 AIR FORCE PROJECT SIGN

The Contractor shall furnish and install a project sign at the location designated by the Contracting Officer's Representative within thirty (30) days after notice to proceed in accordance with EP310-1-6a, attached following this section. Example sign provided, final sign layout to be coordinated with the Contracting Officer's Representative through the Submittal Process.

1.17 SHOP DRAWINGS

Shop Drawings shall be submitted in accordance with Specification Section 01 33 00. Unless otherwise stated, all documents shall be printed or scanned to Portable Document Format (PDF) files of a size suitable for emailing. Files shall be named in accordance with the Unified Guide Specification (UFGS) numbering system. All information including drawings, manufacturer's data, catalog cut sheets, and calculations output from computer program software shall be printed or scanned to be clearly legible, and capable of being reproduced using a standard desktop or office printer. Manufacturer's data, catalog cut sheets, and calculations output from computer program software shall be configured to print to 8 ½" x 11" paper. Scaled drawings shall be configured to print half-size to 11" x 17". The scale for drawings generated from floor plans shall be no less than 1/8" per foot (1/16" per foot when printed half-size).

1.18 SCHEDULE OF AVAILABLE UTILITIES

Existing utilities are available in the Project area. The utilities are privatized at Eglin AFB. For water, sewer, and power, the Contractor shall provide temporary service back to the connection to the water and sewer, or transformer for power, and the privatization Contractor will connect and later disconnect the temporary utility to the existing system. If medium voltage line extension is required, the Privatization Contractor will perform at a cost to the Contractor. The Privatization Contractor would later retire any pole or transformer that was just for temporary use.

As such, the Contractor is responsible for formally requesting temporary service connection 30 days in advance from the privatization contractors through the COR to obtain these temporary utility connections until permanent utility connections are made. The Contractor is required to provide certified backflow preventers for the water and meters for all utilities, as well as pay all connection charges for temporary utilities and notify each utility provider through the COR when the Contractor is ready to remove the temporary connections distribution lines, meters, and associated paraphernalia. The contact information for connection pricing from these utility providers is as follows:

- a. Water/Sewer: ASUS - POC: Roger Ivison; Telephone (850) 377-0924; Email: roger.ivison@asusinc.com.
- b. Electric: CHELCO - POC: Chris Eddy; Telephone: (850) 307-1229; Email: ceddy@chelco.com.

Once utility connections are made, the amount of each utility service consumed shall be charged to or paid for by the Contractor at prevailing rates charged to the Government, as indicated herein or, where the utility is produced by the Government, at reasonable rates determined by the Contracting Officer. The current utility rates are as follows:

- a. Electric: \$0.0953 per KWh.
- b. Natural Gas: \$6.37 per Dekatherms.
- c. Sewer: \$5.04 per kilo gallons.
- d. Water: \$2.733 per kilo gallons.

1.19 CONTRACTOR SITE ACCESS

All contractors and their employees that require access to any Eglin Air Force Base property, to include all ranges, D51/NAVSCOLEOD, site C-6, Camp Rudder, Duke Field, and 7th Special Forces Group complex, will be required to obtain a picture ID from the Base Pass and ID Office, and wear the ID at all times.

Eglin has implemented a requirement for background checks for all contractors and their employees to obtain Base Passes. Background checks will be performed by 96 Security Forces Squadron (SFS) at the Visitor's Center when the individual arrives to pick up their base pass.

The prime contractor will be required to submit the attached memorandum and unescorted access request of personnel indicating days and hours of access, date of birth and country, driver's license number and state to the US Army Corps of Engineers - Eglin AFB Resident Office. This must be accomplished a minimum of 7 (seven) calendar days before access is required. Contractors may use DoD SAFE to submit base passes to USACE and this is preferred, or via email to the project email address. This process will take a full 7 (seven) days and cannot be expedited in any manner.

For individuals that are not local to the Panhandle area, a background check can be performed by 96 SFS prior to arriving to Eglin AFB. Additional information will need to be provided to USACE/96 SFS and an additional 7 calendar days should be anticipated for performing background checks prior to arrival. Coordinate with USACE Eglin Resident Office for information required.

Sample forms are found at the end of this section.

Note: These procedures are subject to change at the directive of the 96 Security Forces command.

All deliveries, to include concrete, asphalt, and construction material, will be subject to inspection and are required to enter the installation and ranges through the Commercial Vehicle Inspection Gate.

1.20 CONSTRUCTION AND DIG PERMITS

A local permitting procedure is in effect at Eglin AFB for any work which may disrupt aircraft or vehicular traffic flow, base utility services, routine activities of the installation or which may involve subsurface excavation. Contractor must plan and detail any work of this nature sufficiently in advance of the proposed work. An AF Form 103, Base Civil Engineering Work Clearance Request (Appendix U), must be submitted at least 10 (ten) working days in advance of the proposed performance date to the Contracting Officer. Work will not begin until approval has been granted. Forms will be made available to the Contractor at Building 696 on Eglin AFB. This includes soil borings.

1.21 SAFETY MARKINGS ON CRANE BOOMS

All cranes shall have a red strobe light and two flags attached to the end of the boom. The flags shall be 18-inches square and international orange in color. The strobe does not need to be flashing during daylight hours

or when the boom is lowered to the ground at night. The strobe shall be flashing when operating during weather in which visibility is reduced or when operating at night. The strobe shall remain flashing if the boom remains elevated at night.

1.22 REQUIREMENTS FOR TEMPORARY CRANES

All cranes used by the Contractor for construction purposes will require written acceptance for their use by the Contracting Officer's Representative. All requests shall be made seven (7) days in advance of the crane's arrival on the job site and shall include such information as latitude and longitude of the crane location, total operating height, mode of transportation and delivery to the project site, period of use and methods of conforming to all safety and airfield operations procedures. Cranes operating at night shall require a red blinking light at the highest point on the crane boom which conforms to Federal Aviation Administration (FAA) requirements and the SPECIAL CONTRACT REQUIREMENT CLAUSE: AIRFIELD SAFETY PRECAUTIONS. FAA Form 7460-1 shall be completed by the Contractor and filed with the FAA. A copy of Form 7460-1 shall also be submitted to the Contracting Officer's representative.

An FAA Form 7460-1 may be required to be completed by the Contractor and filed with the FAA. If required, a copy of Form 7460-1 shall also be submitted to the Contracting Officer's representative. Contractor is responsible for obtaining all necessary FAA Permits for erection of temporary structures.

Address to submit FAA Form 7460-1 is:

Federal Aviation Administration
Southern Regional Office
Air Traffic Division, ASO-530
P.O. Box 20636
Atlanta, GA 30320

Address of the Southern Region Office is:

Southern Region Office
Air Traffic Division, ASO-530
1710 Columbia Avenue
College Park, GA 30337
Tel. 404-305-5585

1.23 CONSTRUCTION MATERIALS

All construction materials shall remain in the designated staging area until ready for use. Storage of materials in areas other than the designated area will not be allowed.

1.24 EQUIPMENT LAYOUT DRAWINGS

The Contractor shall submit "layout drawings" in plan and necessary elevation, of all mechanical, electrical, heating, and ventilating equipment space(s) showing the proposed equipment, ductwork, piping, conduits, etc., with clearances, for approval of the Contracting Officer, whether or not such layout drawings are specified under the various technical sections of the specifications. In spaces having more than one type of equipment, the layout drawings shall indicate the composite arrangement of all types of equipment and all associated work with all

clearances. The layouts of equipment and associated work shall provide adequate and acceptable clearances for entry, servicing, and maintenance. The submittal and approval of equipment layout drawings shall conform to the requirements as herein before specified for shop drawings. Should the Contractor propose to furnish any equipment or standard products requiring allocations of space, or electrical, mechanical, or piping connections thereto, or supports different from those shown or indicated on the plans or in the specifications, he shall prepare and submit full detail drawings to the Contracting Officer for approval showing all changes. The approved detailed drawings shall become a part of the contract and any changes in the construction resulting from revisions in the details and dimensions on the drawings which are required by the substitution of alternate equipment and/or products shall be made at the expense of the Contractor.

1.25 CERTIFICATES OF COMPLIANCE

Each certificate shall be signed by an official authorized to certify on behalf of the manufacturing company and shall contain the name and address of the Contractor, the project name and location, and the quantity and date or dates of shipment or delivery to which the certificates apply. Copies of laboratory test reports submitted with certificates shall contain the address of the testing laboratory and the date or dates of the tests to which the report applies. Certification shall not be construed as relieving the Contractor from furnishing satisfactory material, if, after tests are performed on selected samples, the material is found not to meet the specific requirements.

1.26 EQUIPMENT DATA

(a) Major Equipment. The Contractor shall be required to make a list of all installed new equipment furnished under this contract. This list shall include but not be limited to each piece of equipment which has a serial number. This list shall include all information usually listed on the manufacturer's name plate, so as to positively identify the piece of property. This list shall also include the cost of each piece of installed property (less installation costs) F.O.B. construction site. The above referenced list shall be furnished as soon as possible after equipment is purchased. The list shall be furnished as one (1) electronic copy and shall be furnished to Contracting Officer not later than thirty calendar days prior to completion of any segment of the contract work which has an incremental completion date. Listing will be on Government furnished MOB Form 897, available from the Contracting Officer.

(b) Other Equipment. The Contractor will be required to furnish a brochure, catalog cut, parts list, manufacturer's data sheet or other publication (including the manufacturer's name and address) which will show detailed parts data on all other equipment, such as hardware, plumbing and lighting fixtures, etc., subject to repair and maintenance procedures. The data shall be furnished in one (1) electronic copy to the Contracting Officer not later than thirty calendar days prior to completion of any segment of the contract work which has an incremental completion date.

1.27 FACILITY ENVIRONMENTAL REQUIREMENTS

Acceptable environmental conditions shall be established prior to installation of any temperature or humidity sensitive finishes, such as but not limited to drywall, paint, casework, carpet and tile, acoustical ceiling tile, etc. Acceptable environmental conditions shall be

established at least 24 hours prior to the start of finish installation. Monitor, document, and maintain environmental conditions daily, or more frequently as needed, throughout the remainder of construction to ensure that there is no damage to installed work due to unacceptable temperature or humidity levels. Where requirements vary for different finishes the most stringent shall be maintained. Minimum standards shall be maintained to ensure that mold growth does not occur. Finishes damaged due to unacceptable temperature or humidity levels shall be replaced in their entirety at no additional cost to the Government.

1.28 ASBESTOS MATERIALS AND LEAD BASED PAINTS

The Contractor shall not use materials containing Asbestos or Lead Based Paints in the construction of this facility. Upon completion of the construction, the Contractor shall submit one (1) electronic copy of an Asbestos and Lead Based Paint Certification Letter to the Contracting Officer's Representative (COR) stating that no lead based paints or materials containing asbestos were used in the construction of the new facilities.

1.29 ELECTRONIC MAIL SYSTEM

The Contractor shall provide and maintain for the life of this contract an electronic mail system which shall interface, connect to and be compatible with the existing electronic mail system in the Corps of Engineers Resident Office at Eglin AFB, FL. The Contractors electronic mail system shall transfer and receive correspondence between the Resident Office without loss or modification of formatting codes or special characters.

The Resident Office is currently utilizing Exchange/MS Outlook for Windows and is Internet accessible. The Corps Internet E-mail gateway accepts binary files in uuencoded format. Any files that cannot be sent via email due to file size should be sent via DoD Safe. .

During construction, all Requests For Information (RFIs) and contract correspondence including field sketched drawings shall be transmitted to the Corps of Engineers Resident Office at Eglin AFB, FL. in an electronic format. The RFIs shall be saved into a ".pdf" format using Adobe Acrobat software, latest version. A project-specific email inbox will be provided at the beginning of the contract. All official email traffic should be sent to this inbox.

The Contractor's electronic mail system shall have the capability of sending and receiving text, graphic, and drawing files developed on the following software:

- 1) Microsoft Word, Version 2003 or newer
- 2) WordPerfect, Version 12.0
- 3) AutoCAD, Version 2008 or newer
- 4) Adobe Acrobat, Version 6.0 or newer

The Contractor shall bear the responsibility to ensure total hardware and software compatibility with the Government's system when transferring and receiving information.

1.30 TESTING AND BALANCING FOR HVAC SYSTEMS

The Construction Contractor shall retain the services of an Independent Firm for Testing and Balancing (TAB) HVAC Systems as specified in

SECTION: TESTING, ADJUSTING, AND BALANCING. Firm shall be either a member of the Associated Air Balance Council (AABC) or certified by the National Environmental Balancing Bureau (NEBB). The TAB Firm shall be a subcontractor of the prime contractor, and shall report to and be paid by the prime contractor.

1.31 LAYOUT OF WORK

The Contractor shall lay out its work from Government-established base lines and bench marks indicated on the drawings, and shall be responsible for all measurements in connection with the layout. The Contractor shall furnish, at its own expense, all stakes, templates, platforms, equipment, tools, materials, and labor required to lay out any part of the work. The Contractor shall be responsible for executing the work to the lines and grades that may be established or indicated by the Contracting Officer. The Contractor shall also be responsible for maintaining and preserving all stakes and other marks established by the Contracting Officer until authorized to remove them. If such marks are destroyed by the Contractor or through its negligence before their removal is authorized, the Contracting Officer may replace them and deduct the expense of the replacement from any amounts due or to become due to the Contractor.

1.32 PAYMENT FOR MATERIALS DELIVERED OFFSITE

a. Pursuant to FAR Clause 52.232-5, "Payment Under Fixed-Price Construction Contracts," materials delivered to the Contractor at locations other than the site of the work may be taken into consideration in making payments if included in payment estimates and if all the conditions of the contract clauses are fulfilled. Payment for items delivered to locations other than the work site will be limited to (1) materials required by the technical provisions; or (2) materials that have been fabricated to the point where they are identifiable to an item of work required under this contract.

b. Such payment will be made only after receipt of paid or receipted invoices or invoices with canceled check showing title to the items in the prime contractor and including the value of materials and labor incorporated into the item. Petroleum products, including fuel, will be considered for payment as a material delivered offsite.

1.33 COORDINATION CONFERENCES

Weekly coordination conferences will be held by the Contracting Officer's Representative and the Contractor throughout the life of this contract. Coordination conferences will be held to discuss contract administration, Contractor quality control, phasing, scheduling, and other aspects relating to this construction. The Using Agency, Corps of Engineers and the Contractor will be represented at each of these meetings. Similar information concerning replacement personnel shall be forwarded to the Contracting Officer's Representative, should any replacement be required at any time during the life of this contract. Coordination conferences will be scheduled to occur on a weekly basis. The Contractor shall develop the Meeting Minutes for each Coordination conference. A copy of the meeting minutes shall be provided to the Corps and all attendees via e-mail no later than 48 hours after each meeting. The Contractor shall develop and maintain a list of action items that arise during construction or at each Coordination Conference. The Action Items list shall describe each Issue/Action Item and state what organization/person is tasked with its resolution. Blanks, or cells, shall be provided for dates when the

Issue/Action Item was first raised, the due date for its resolution, and the date of actual resolution.

1.34 PERMITS AND RESPONSIBILITIES

The Government has obtained the following applicable permits/permit applications related to the design and construction of this project:

- a). FDEP 10-2 Stormwater Permit.
- b). Joint Application for Individual and Conceptual Environmental Resource Permit/Authorization to Use State-Owned Submerged Lands/Federal Dredge and Fill Permit, submitted to FDEP/Water Management Districts/U.S. Army Corps of Engineers.

The contractor will be required to obtain the as-built certifications for the permits identified above and submitting to the district/FDEP for permit closeout/transfer. The Contractor shall utilize a professional engineer to monitor the construction activities for stormwater improvements per the conditions of the approved permit. A professional engineer is required by permit conditions to submit the construction completion permits to the permitting agency. Accordingly, the contractor will be responsible for fully coordinating with the Contracting Officer regarding information for as-built certifications, properly executed, as required by each individual permit.

ASUS will obtain and close-out, upon completion, the following permits/permit applications related to the design and construction of this permit:

- a) Notice of Intent to Use the General Permit for Construction of Water Main Extensions for PWSs.
- b) Notification/Application for Constructing a Domestic Wastewater Collection/Transmission System.

The construction contractor will obtain and close-out, upon completion, the following applicable permits/permit applications related to the design and construction of this project:

- a) NPDES Notice of Intent

1.35 CONSTRUCTION DEBRIS DISPOSALS

Cleared trees, limbs and other vegetation shall be disposed of at an approved disposal site off Government controlled lands.

All other construction debris shall be disposed of at an approved disposal site off Government controlled lands.

1.36 HAZARDOUS MATERIALS AND WASTES MANAGEMENT

All hazardous materials and waste resulting from the construction of this project shall be managed in accordance with local, state, federal and Eglin AFB rules and regulations. All universal waste such as spent fluorescent lamps, batteries, mercury thermostats, smoke detectors, and mercury switches must be managed and handled in accordance with the above-mentioned directives. Hazardous materials and waste such as fuels and oils of all types, used tires, computer monitors, all electronic

devices, aerosol spray cans (including empties), paints, adhesives, corrosives, nonflammable and noncorrosive cleaners, hydraulic fluid, antifreeze, etc. must be managed in accordance with above-mentioned compliance agencies. The Contractor's Quality Control Manager shall contact COR and 96 CEG/CEV if handling procedures for hazardous waste and materials is unclear.

The use of fuel storage tanks on Base must be approved by the 96 CEG/CEV. Temporary gasoline storage will NOT be permitted on Base. Any tank, container, or equipment with an oil or fuel capacity of 55 gallons or more approved for use on Eglin AFB shall have a means of secondary containment, spill containment (spill kits), and/or spill procedures in place that prevents the flow of spilled oil or hazardous materials into navigable waters.

Contractor vehicle and heavy equipment maintenance (including oil changing, lubrication, and vehicle washing) is not authorized on base.

1.37 HAZARDOUS OR TOXIC MATERIAL SPILLS

Within ten (10) days of Notice To Proceed (NTP), the Contractor shall prepare a Spill Prevention Control and Countermeasures (SPCC) Plan in accordance with CFR 40 Part 112 to address spill prevention and countermeasures for tanks and heavy equipment used on Base.

Any fuel, oil, hydraulic fluid, chemical, or other hazardous or toxic material spill on Eglin AFB shall be reported to the Base Fire Department by phoning "911", or to 96 CEG/CEV through the Contracting Officer's Representative regardless of the amount.

1.38 RECYCLING OF HAZARDOUS OR TOXIC MATERIALS

All fluorescent, metal halide, mercury, or high pressure sodium lighting bulbs or tubes, fluorescent ballasts, smoke detectors, and mercury switches/thermostats identified for disposal shall be turned in to 96 CEG/CEV for recycling. The contractor shall call 96 CEG/CEV for a turn-in appointment (normally Tuesdays and Thursdays). Each type of the items listed above shall be separated and placed in containers capable of being closed properly. Fluorescent tubes shall not be taped together. If the original container is not available, the Contractor shall use a box as close as possible to the size of the original container. A stick-on label must be placed on each box describing the contents. The labels can be hand-written or computer generated. The Contractor shall refrain from breaking lamps, however, broken lamps should be collected as well.

1.39 BURIED PIPING AND UTILITIES

The Contractor shall provide a tracer wire on the top of all non-metallic piping, conduit or other underground utilities buried 6-inches below finished grade or deeper. The tracer wire shall be magnetic detectable conductor, brightly colored plastic covering, imprinted with the type of service in large letters. Contractor shall submit for approval product data on the tracer wire to be used.

1.40 EXISTING ROADWAYS

The construction contractor shall limit construction loads as necessary to avoid damaging the existing roads. Prior to starting construction, the Contractor shall make a joint inspection of existing roads with

Contracting Officer's Representative and document the condition of these roads in a report and a video tape. Video tape shall be provided to COR within 10 days of inspection. Damage to existing roads caused by contractor equipment during construction shall be repaired by the construction contractor at the conclusion of construction at no additional cost to the Government.

1.41 PROTECTION OF ENVIRONMENTALLY SENSITIVE AREAS/ENDANGERED SPECIES

The construction site, as well as the surrounding area, contains species currently considered endangered. These include, but are not limited to Red Cockaded Woodpeckers. The contractor's project manager, superintendent, quality control manager and back-up to the Q/C manager shall attend a briefing at the Jackson Guard to learn to identify these endangered species. Points of Contact are Mr. Jeremy Preston, (850)883-1153, and Ms. Amanda Robydek, (850) 882-8395, or the Contracting Officer.

1.41.1 Gopher Tortoise Survey

A gopher tortoise survey shall be required. The General Contractor shall contact Eglin Natural Resources (Jackson Guard) to arrange for the survey to take place within 30 days of ground disturbing activities. The Survey shall be conducted by Eglin Natural Resources staff. Point of Contact is Wayne Pittman, 96 CEG/CEIEA, 978-1260 or Rodney Felix, 96 CEG/CEIEA, 883-1153. If contact cannot be made, consult with the Contracting Officer's Representative. If tortoise burrows are found to conflict with the proposed project site, and burrows cannot be avoided by at least 25 feet, the tortoise(s) must be relocated. Note that tortoises cannot be relocated if the forecasted low temperature is below 50 degrees for 3 consecutive days. The actual tortoise relocation will be executed by Eglin Natural Resources staff.

1.42 TESTING AND INSPECTING

The following statement replaces paragraphs found in the technical specifications for all buildings and aspects of the project calling for the Government or Owner to engage and pay for Testing and Inspecting:

Contractor will engage and pay for qualified independent testing and inspecting agencies to perform field tests and inspections and prepare reports as required in specification sections that require such tests. The Contracting Officer or their Representative shall not be responsible for engaging the services.

1.43 BRAND NAMES OR EQUAL PRODUCTS

The Contractor may provide alternate products equal to those specifically referenced by brand name in the specifications. The alternate products shall fully meet the salient characteristics of the brand name products as described in the specifications to be considered equal. The Contractor shall submit the alternate products showing the salient characteristics for Government Approval after award in accordance with Section 01 33 00 Submittal Procedures.

1.44 RED ZONE MEETINGS

The contractor shall have a series of pre-final construction Red Zone Meetings to discuss, define and achieve consensus on the construction and financial status of the project. The ultimate goal is to build a schedule

of events necessary to achieve project completion and financial closeout in keeping with Air Force Execution Goals. These goals are to complete projects within original budget, complete projects within original schedule, physical completion within 90 days of BOD and financial closeout within 180 days of BOD.

a. Red Zone Meetings shall be started 90 days prior to the expected completion of a facility, or when the facility reaches 80% completion.

b. The Red Zone process initiates the Enterprise Business Process (EBP), which the Corps of Engineers utilizes for the closeout of MILCON projects (USACE MILCON Project Closeout, Enterprise Business Process, October 2007, Final Version.).

c. Completion Milestones. The red zone meeting establishes milestone estimated completion dates and OPRs for all the actions necessary to complete the project. It indicates all remaining activities including the Action Officer, the date due, the status, the actual completion date and any comments.

1.45 SUBMISSION OF INTERIM DD FORM 1354 - TRANSFER AND ACCEPTANCE OF MILITARY REAL PROPERTY

Using the blank DD Form 1354 provided at the end of this section, the Contractor shall submit an Interim DD Form 1354. Using this Interim DD Form 1354, the Contractor shall submit the Interim DD Form 1354 for the project no later than thirty (30) days prior to the Beneficial Occupancy Date (BOD). Category Code numbers found on the DD Form 1354 Checklist provided at the end of this section shall be used in completing the Final DD Form 1354. Additional Category Codes can be found in the publication entitled "Air Force Real Property Category Code Descriptions" which can be obtained from the Directorate of Technical Support, Air Force Civil Engineer Support Agency, Tyndall AFB, FL 32403-5319.

1.46 CORRESPONDENCE AND ELECTRONIC COMMUNICATION

For ease and speed of communications, both the Government and Contractor shall exchange correspondence and all other documents in electronic format unless otherwise stated in the specifications. Electronic submission will be accomplished by the following methods: email and through the Resident Management System - Contractor Mode (RMS-CM) software. Format for electronic submissions will be in portable document format (.pdf). Documents include all general correspondence, administrative plans, all material submittals including shop drawings, progress schedules, submittal registers, requests for information (RFIs), Quality Control (QC) test results, pay requests, etc. Anything submitted via RMS-CM shall be emailed to the corresponding project email inbox.

Where effective receipt dates are required, the date the submission is received in the project email inbox and through RMS-CM will be the receipt date. Correspondence, submittals, pay requests, etc. will not be marked received until it is received in both locations.

1.47 RATES OF WAGES

Wage rates are included at the end of this section.

LRSO HARDWARE SOFTWARE DEVELOPMENT FACILITY
EGLIN AIR FORCE BASE, FLORIDA

W9127826RA012
MEF22007

PART 2 PRODUCTS (NOT APPLICABLE)

PART 3 EXECUTION (NOT APPLICABLE)

-- End of Section --

SUBMITTAL REGISTER

CONTRACT NO.

TITLE AND LOCATION
 LRSO Hardware Software Development Facility

CONTRACTOR

ACTIVITY NO	TRANSMITTAL NO	SPEC SECT	DESCRIPTION ITEM SUBMITTED	PARAGRAPH	GOVT CLASSIFICATION	CONTRACTOR: SCHEDULE DATES			CONTRACTOR ACTION		APPROVING AUTHORITY				MAILED TO CONTR/ DATE RCD FRM APPR AUTH	REMARKS		
						SUBMIT	APPROVAL NEEDED BY	MATERIAL NEEDED BY	ACTION CODE	DATE OF ACTION	DATE FWD TO APPR AUTH/	DATE RCD FROM CONTR	DATE FWD TO OTHER REVIEWER	DATE RCD FROM OTH REVIEWER			ACTION CODE	DATE OF ACTION
		01 00 00	SD-01 Preconstruction Submittals															
			Hazard Analysis	1.9	G RO													
			AF Form 103, Base Civil	1.20	G RO													
			Engineering Work Clearance Request															
			Contractor's Area Use Plan	1.15	G RO													
			SD-07 Certificates															
			Asbestos and Lead Based Paint Certification Letter	1.28	G RO													
			SD-11 Closeout Submittals															
			Redlined As-Built Drawings	1.14	G RO													
			Progress As-Built Building Information Model (BIM)	1.14	G RO													
			Final As-Built BIM	1.14	G RO													
			As-Built Drawings	1.14	G RO													
		01 32 01.00 10	SD-01 Preconstruction Submittals															
			Project Scheduler Qualifications	1.3	G													
			Preliminary Project Schedule	3.4.1	G													
			Initial Project Schedule	3.4.2	G													
			Periodic Schedule Update	3.6.2	G													
		01 33 00	SD-01 Preconstruction Submittals															
			Submittal Register	1.8	G													
		01 33 29	SD-05 Design Data															
			Final Design High Performance and Sustainable Building Checklist	1.5.3.2	G													

SUBMITTAL REGISTER

CONTRACT NO.

TITLE AND LOCATION

LRSO Hardware Software Development Facility

CONTRACTOR

ACTIVITY NO	TRANSMITTAL NO	SPEC SECT	DESCRIPTION ITEM SUBMITTED	PARAGRAPH	GOVT CLASSIFICATION	CONTRACTOR: SCHEDULE DATES			CONTRACTOR ACTION		APPROVING AUTHORITY				MAILED TO CONTR/ DATE RCD FRM APPR AUTH	REMARKS		
						SUBMIT	APPROVAL NEEDED BY	MATERIAL NEEDED BY	ACTION CODE	DATE OF ACTION	DATE FWD TO APPR AUTH/	DATE RCD FROM CONTR	DATE FWD TO OTHER REVIEWER	DATE RCD FROM OTH REVIEWER			ACTION CODE	DATE OF ACTION
		01 33 29	Final Design Sustainability eNotebook	1.5.3.2	G													
			SD-11 Closeout Submittals															
			Final High Performance and Sustainable Building Checklist	1.5.3.2	G													
			Final Sustainability eNotebook	1.5.3.2	G													
		01 35 26	SD-01 Preconstruction Submittals															
			Accident Prevention Plan (APP)	1.8.1	G													
			Final IAQ Management Plan	1.15	S													
			Indoor Air Quality (IAQ) Management Plan	1.15	G													
			SD-06 Test Reports															
			LHE Inspection Reports	1.12.2														
			Monthly Exposure Reports	1.5	G													
			SD-07 Certificates															
			Activity Hazard Analysis (AHA)	1.9	G													
			Certificate of Compliance	1.12.3														
			Hot Work Permit	1.13														
			Standard Lift Plan	1.12.3.2	G													
			Critical Lift Plan	1.12.3.2	G													
		01 45 00	SD-01 Preconstruction Submittals															
			Contractor Quality Control (CQC) Plan	1.5.2	G													
			SD-06 Test Reports															
			Verification Statement	1.12.3														
		01 45 35	SD-01 Preconstruction Submittals															

SUBMITTAL REGISTER

CONTRACT NO.

TITLE AND LOCATION

LRSO Hardware Software Development Facility

CONTRACTOR

ACTIVITY NO	TRANSMITTAL NO	SPEC SECT	DESCRIPTION ITEM SUBMITTED	PARAGRAPH	GOVT CLASSIFICATION	CONTRACTOR: SCHEDULE DATES			CONTRACTOR ACTION		APPROVING AUTHORITY				MAILED TO CONTR/ DATE RCD FRM APPR AUTH	REMARKS	
						SUBMIT	APPROVAL NEEDED BY	MATERIAL NEEDED BY	ACTION CODE	DATE OF ACTION	DATE FWD TO APPR AUTH/ DATE RCD FROM CONTR	DATE FWD TO OTHER REVIEWER	DATE RCD FROM OTH REVIEWER	ACTION CODE			DATE OF ACTION
		01 45 35	SIOR Letter of Acceptance	3.1.1	G												
			Project Manual	3.1.1	G												
			Project Manual	3.1.1	G												
			Contractor's Statement of Responsibility	1.2	G												
			SD-06 Test Reports														
			Daily Reports	3.1.1													
			Daily Reports	3.1.3													
			Biweekly Reports	3.1.1													
			SD-07 Certificates														
			Steel Truss Plant Quality Assurance Program	2.1													
			Certificate of Compliance	2.1													
			Special Inspector of Record	1.5.10	G												
			Special Inspector	1.5	G												
			SD-11 Closeout Submittals														
			Comprehensive Final Report	3.1.1	G												
			Comprehensive Final Report	3.1.3	G												
		01 50 00	SD-01 Preconstruction Submittals														
			Construction Site Plan	1.3	G												
			Traffic Control Plan	3.2.1	G												
			Haul Road Plan	2.2.1	G												
			Contractor Computer Cybersecurity Compliance Statements	1.6.1.4	G												

SUBMITTAL REGISTER

CONTRACT NO.

TITLE AND LOCATION

LRSO Hardware Software Development Facility

CONTRACTOR

ACTIVITY NO	TRANSMITTAL NO	SPEC SECT	DESCRIPTION ITEM SUBMITTED	PARAGRAPH	GOVT CLASSIFICATION	CONTRACTOR: SCHEDULE DATES			CONTRACTOR ACTION		APPROVING AUTHORITY				MAILED TO CONTR/ DATE RCD FRM APPR AUTH	REMARKS		
						SUBMIT	APPROVAL NEEDED BY	MATERIAL NEEDED BY	ACTION CODE	DATE OF ACTION	DATE FWD TO APPR AUTH/	DATE RCD FROM CONTR	DATE FWD TO OTHER REVIEWER	DATE RCD FROM OTH REVIEWER			ACTION CODE	DATE OF ACTION
		01 50 00	Contractor Temporary Network Cybersecurity Compliance Statements	1.6.6	G													
			SD-03 Product Data Backflow Preventers	1.4	G													
			SD-06 Test Reports Backflow Preventer Tests	3.3														
			SD-07 Certificates Backflow Tester	1.4.1														
			Backflow Preventers	1.4														
		01 57 19	SD-01 Preconstruction Submittals UXO Recognition Plan and Training	1.6	G													
			Preconstruction Survey	1.5.1														
			Regulatory Notifications	1.5.2														
			Environmental Manager Qualifications	1.5.4														
			Employee Training Records	1.5.5														
			Environmental Protection Plan	1.7	G													
			Dirt and Dust Control Plan	1.7.9.1														
			Solid Waste Management Permit	1.9														
			Stormwater Pollution Prevention Plan	3.3.1.1	G													
			Stormwater Notice of Intent	3.3.1.2														
			Spill Prevention Control And Countermeasure (SPCC) Plan	3.16.2	G													

SUBMITTAL REGISTER

CONTRACT NO.

TITLE AND LOCATION

LRSO Hardware Software Development Facility

CONTRACTOR

ACTIVITY NO	TRANSMITTAL NO	SPEC SECT	DESCRIPTION ITEM SUBMITTED	PARAGRAPH	GOVT CLASSIFICATION	CONTRACTOR: SCHEDULE DATES			CONTRACTOR ACTION		APPROVING AUTHORITY				MAILED TO CONTR/ DATE RCD FRM APPR AUTH	REMARKS		
						SUBMIT	APPROVAL NEEDED BY	MATERIAL NEEDED BY	ACTION CODE	DATE OF ACTION	DATE FWD TO APPR AUTH/	DATE RCD FROM CONTR	DATE FWD TO OTHER REVIEWER	DATE RCD FROM OTH REVIEWER			ACTION CODE	DATE OF ACTION
		01 57 19	SD-06 Test Reports															
			Monthly Solid Waste Disposal Report	1.9.1	G													
			Inspection Reports	3.3.1.3														
			Laboratory Analysis	3.8.1.1.2														
			SD-07 Certificates															
			Employee Training Records	1.5.5	G													
			Erosion and Sediment Control Inspector	1.5.5														
			SD-11 Closeout Submittals															
			Regulatory Notifications	1.5.2	G													
			Assembled Employee Training Records	1.5.5	G													
			Solid Waste Management Permit	1.9	G													
			Stormwater Notice of Termination	3.3.1.4	G													
			Waste Determination Documentation	3.8.1	G													
			Project Solid Waste Disposal Documentation Report	3.8.2.1	G													
			Sales Documentation	3.8.2.1	G													
			Hazardous Waste/Debris Management	3.8.3.1	G													
			Disposal Documentation for Hazardous and Regulated Waste	3.8.3.6	G													
		01 74 19	SD-01 Preconstruction Submittals															

SUBMITTAL REGISTER

CONTRACT NO.

TITLE AND LOCATION

LRSO Hardware Software Development Facility

CONTRACTOR

ACTIVITY NO	TRANSMITTAL NO	SPEC SECT	DESCRIPTION ITEM SUBMITTED	PARAGRAPH	GOVT CLASSIFICATION	CONTRACTOR: SCHEDULE DATES			CONTRACTOR ACTION		APPROVING AUTHORITY				MAILED TO CONTR/ DATE RCD FRM APPR AUTH	REMARKS	
						SUBMIT	APPROVAL NEEDED BY	MATERIAL NEEDED BY	ACTION CODE	DATE OF ACTION	DATE FWD TO APPR AUTH/ DATE RCD FROM CONTR	DATE FWD TO OTHER REVIEWER	DATE RCD FROM OTH REVIEWER	ACTION CODE			DATE OF ACTION
		01 74 19	Construction Waste Management Plan	1.7	G												
			SD-06 Test Reports														
			Quarterly Reports	1.9.2													
			Annual Report	1.9.3													
			SD-11 Closeout Submittals														
			Final Construction Waste Diversion Report	1.10	S												
		01 78 00	SD-03 Product Data														
			Warranty Management Plan	1.5.1													
			Warranty Tags	1.5.5													
			Spare Parts Data	1.4													
			SD-08 Manufacturer's Instructions														
			Instructions	1.5.1													
			SD-11 Closeout Submittals														
			Certification of EPA Designated Items	2.1	G												
			Certification Of USDA Designated Items	2.2	G												
		01 78 23	SD-10 Operation and Maintenance Data														
			Facility Data Workbook	1.4	G												
			Training Plan	3.1.1	G												
			Training Outline	3.1.3	G												
			Training Content	3.1.2	G												

SUBMITTAL REGISTER

CONTRACT NO.

TITLE AND LOCATION

LRSO Hardware Software Development Facility

CONTRACTOR

ACTIVITY NO	TRANSMITTAL NO	SPEC SECT	DESCRIPTION ITEM SUBMITTED	PARAGRAPH	GOVT CLASSIFICATION	CONTRACTOR: SCHEDULE DATES			CONTRACTOR ACTION		APPROVING AUTHORITY				MAILED TO CONTR/ DATE RCD FRM APPR AUTH	REMARKS		
						SUBMIT	APPROVAL NEEDED BY	MATERIAL NEEDED BY	ACTION CODE	DATE OF ACTION	DATE FWD TO APPR AUTH/	DATE RCD FROM CONTR	DATE FWD TO OTHER REVIEWER	DATE RCD FROM OTH REVIEWER			ACTION CODE	DATE OF ACTION
		01 78 23	Operation And Maintenance Manual, Progress Submittal	3.2.1	G													
			Operation And Maintenance Manual, Prefinal Submittal	3.2.2	G													
			Operation And Maintenance Manual, Final Submittal	3.2.3	G													
			SD-11 Closeout Submittals															
			Training Video Recording	3.1.4	G													
			Validation of Training Completion	3.1.6	G													
			Training Plan	3.1.1	G													
			Record Drawings And Utility Systems	1.6.6.7	G													
		01 91 00.15	SD-06 Test Reports															
			Completed Construction Observation Checklists	3.6	G													
			Design Review Report	3.1	G													
			Interim Construction Phase Commissioning Plan	3.5	G													
			Final Construction Phase Commissioning Plan	3.5	G													
			Issues Log	1.11	G													
			SD-07 Certificates															
			Commissioning Firm	1.8	G													
			SD-10 Operation and Maintenance Data															

SUBMITTAL REGISTER

CONTRACT NO.

TITLE AND LOCATION

LRSO Hardware Software Development Facility

CONTRACTOR

ACTIVITY NO	TRANSMITTAL NO	SPEC SECT	DESCRIPTION ITEM SUBMITTED	PARAGRAPH	GOVT CLASSIFICATION	CONTRACTOR: SCHEDULE DATES			CONTRACTOR ACTION		APPROVING AUTHORITY				MAILED TO CONTR/ DATE RCD FRM APPR AUTH	REMARKS	
						SUBMIT	APPROVAL NEEDED BY	MATERIAL NEEDED BY	ACTION CODE	DATE OF ACTION	DATE FWD TO APPR AUTH/ DATE RCD FROM CONTR	DATE FWD TO OTHER REVIEWER	DATE RCD FROM OTH REVIEWER	ACTION CODE			DATE OF ACTION
		01 91 00.15	Maintenance and Service Life Plan	3.10	G												
			Systems Manual	3.9	G												
			SD-11 Closeout Submittals														
			Final Commissioning Report	3.11	G												
			Final Commissioning Report (eNotebook)	3.11	S												
		03 30 00	SD-01 Preconstruction Submittals														
			Concrete Curing Plan	1.6.3.1													
			Quality Control Program	1.6.5	G												
			Quality Control Personnel Certifications	1.6.6	G												
			Quality Control Organizational Chart	1.6.6													
			Laboratory Accreditation	1.6.8	G												
			Cold Weather Plan	1.6.5.1	G												
			Hot Weather Plan	1.6.5.2	G												
			Maturity Method Data	3.3.11													
			SD-02 Shop Drawings														
			Reinforcing Steel	1.6.2.1	G												
			Placement Sequence and Jointing Plan	3.10.1	G												
			SD-03 Product Data														
			Joint Sealants	2.4.4													
			Joint Filler	2.4.3													
			Formwork Materials	2.1													

SUBMITTAL REGISTER

CONTRACT NO.

TITLE AND LOCATION

LRSO Hardware Software Development Facility

CONTRACTOR

ACTIVITY NO	TRANSMITTAL NO	SPEC SECT	DESCRIPTION ITEM SUBMITTED	PARAGRAPH	GOVT CLASSIFICATION	CONTRACTOR: SCHEDULE DATES			CONTRACTOR ACTION		APPROVING AUTHORITY				MAILED TO CONTR/ DATE RCD FRM APPR AUTH	REMARKS	
						SUBMIT	APPROVAL NEEDED BY	MATERIAL NEEDED BY	ACTION CODE	DATE OF ACTION	DATE FWD TO APPR AUTH/ DATE RCD FROM CONTR	DATE FWD TO OTHER REVIEWER	DATE RCD FROM OTH REVIEWER	ACTION CODE			DATE OF ACTION
		03 30 00	Cementitious Materials	2.3.1													
			Vapor Barrier	2.4.5													
			Concrete Curing Materials	2.4.1													
			Reinforcement	2.6													
			Liquid Chemical Floor Hardeners and Sealers	2.4.2.1													
			Admixtures	2.3.4													
			Mechanical Reinforcing Bar Connectors	2.6.2													
			Local/Regional Materials	1.8.1													
			Biodegradable Form Release Agent	2.2.2													
			Pumping Concrete	1.6.3.2													
			SD-04 Samples														
			Mockup	3.3.6	G												
			SD-05 Design Data														
			Concrete Mixture Proportion	1.6.1.1	G												
			SD-06 Test Reports														
			Concrete Mixture Proportion	1.6.1.1	G												
			Fly Ash	1.6.4.1													
			Pozzolans	1.6.4.1													
			Silica Fume	1.6.4.3													
			Slag Cement	1.6.4.2													
			Aggregates	1.6.4.4													
			Compressive Strength Tests	3.12.3.3	G												

SUBMITTAL REGISTER

CONTRACT NO.

TITLE AND LOCATION

LRSO Hardware Software Development Facility

CONTRACTOR

ACTIVITY NO	TRANSMITTAL NO	SPEC SECT	DESCRIPTION ITEM SUBMITTED	PARAGRAPH	GOVT CLASSIFICATION	CONTRACTOR: SCHEDULE DATES			CONTRACTOR ACTION		APPROVING AUTHORITY				MAILED TO CONTR/ DATE RCD FRM APPR AUTH	REMARKS		
						SUBMIT	APPROVAL NEEDED BY	MATERIAL NEEDED BY	ACTION CODE	DATE OF ACTION	DATE FWD TO APPR AUTH/	DATE RCD FROM CONTR	DATE FWD TO OTHER REVIEWER	DATE RCD FROM OTH REVIEWER			ACTION CODE	DATE OF ACTION
		03 30 00	Unit Weight of Structural Concrete	3.12.3.5														
			Air Content	3.12.3.4														
			Slump Tests	3.12.3.1														
			Water	2.3.2														
			SD-07 Certificates															
			Reinforcing Bars	2.6.1														
			Welder Qualifications	1.9														
			Silica Fume Manufacturer's Representative	1.6.3.3														
			VOC Content for Form Release Agents, Curing Compounds, and Concrete Penetrating Sealers	1.6.3.4														
			Safety Data Sheets	1.6.3.5														
			Ready-mixed Concrete Manufacturer (Plant) and Trucks	2.5.5														
			Field Testing Technician and Testing Agency	1.6.6.2														
			SD-08 Manufacturer's Instructions															
			Liquid Chemical Floor Hardeners and Sealers	2.4.2.1														
			Joint Sealants	2.4.4	S													
			Curing Compounds	2.4.1														
		03 54 13	SD-03 Product Data															
			Product Data	2.1.1	G AE													
		04 20 00	SD-03 Product Data															

SUBMITTAL REGISTER

CONTRACT NO.

TITLE AND LOCATION

LRSO Hardware Software Development Facility

CONTRACTOR

ACTIVITY NO	TRANSMITTAL NO	SPEC SECT	DESCRIPTION ITEM SUBMITTED	PARAGRAPH	GOVT CLASSIFICATION	CONTRACTOR: SCHEDULE DATES			CONTRACTOR ACTION		APPROVING AUTHORITY					REMARKS			
						SUBMIT	APPROVAL NEEDED BY	MATERIAL NEEDED BY	ACTION CODE	DATE OF ACTION	DATE FWD TO APPR AUTH/	DATE RCD FROM CONTR	DATE FWD TO OTHER REVIEWER	DATE RCD FROM OTH REVIEWER	ACTION CODE		DATE OF ACTION	MAILED TO CONTR/	DATE RCD FRM APPR AUTH
		04 20 00	Hot Weather Procedures	1.5.1	G														
			Cold Weather Procedures	1.5.2	G														
			Clay or Shale Brick	2.2.2	G														
			Cementitious Materials	2.3.1.1	G														
			SD-04 Samples																
			Mock-Up Panel	1.3.1.1	G														
			Clay or Shale Brick	2.2.2	G														
			Concrete Masonry Units (CMU)	2.2.3.2	G														
			Admixtures for Masonry Mortar	2.3.1.4	G														
			Anchors, Ties, and Bar	2.5.1	G														
			Positioners																
			SD-05 Design Data																
			Masonry Compressive Strength	2.1.2	G														
			Stone	2.2.4	G														
			SD-06 Test Reports																
			Efflorescence Test	2.2.2.1.5															
			Field Testing of Mortar	3.6.1.1															
			SD-07 Certificates																
			Special Masonry Inspector	1.3.2															
			Qualifications																
			Clay or Shale Brick	2.2.2															
			Concrete Masonry Units (CMU)	2.2.3.2															
			Cementitious Materials	2.3.1.1															
			Anchors, Ties, and Bar	2.5.1															
			Positioners																
			SD-08 Manufacturer's Instructions																

SUBMITTAL REGISTER

CONTRACT NO.

TITLE AND LOCATION

LRSO Hardware Software Development Facility

CONTRACTOR

ACTIVITY NO	TRANSMITTAL NO	SPEC SECT	DESCRIPTION ITEM SUBMITTED	PARAGRAPH	GOVT CLASSIFICATION	CONTRACTOR: SCHEDULE DATES			CONTRACTOR ACTION		APPROVING AUTHORITY				MAILED TO CONTR/ DATE RCD FRM APPR AUTH	REMARKS	
						SUBMIT	APPROVAL NEEDED BY	MATERIAL NEEDED BY	ACTION CODE	DATE OF ACTION	DATE FWD TO APPR AUTH/ DATE RCD FROM CONTR	DATE FWD TO OTHER REVIEWER	DATE RCD FROM OTH REVIEWER	ACTION CODE			DATE OF ACTION
		04 20 00	Admixtures for Masonry Mortar	2.3.1.4													
			SD-10 Operation and Maintenance Data														
			Take-Back Program	3.8													
			SD-11 Closeout Submittals														
			Clay Units	2.2.2.1.4	S												
			Recycled Content	2.2.3.2.1	S												
		05 05 20	SD-01 Preconstruction Submittals														
			Installer Qualifications	1.5.1.1	G												
			Post-Installed Anchor Special	1.5.1.2	G												
			Inspector Qualifications														
			SD-03 Product Data														
			Mechanical Anchors in Concrete	2.1.1.3	G												
			Adhesive Anchor System in Concrete	2.1.1.4	G												
			Non-Shrink, Non-Metallic Grout	3.1.3	G												
			SD-06 Test Reports														
			Post-Installed Anchor Special	3.3.4	G												
			Inspections Report														
			SD-07 Certificates														
			Post-Installed Anchor	2.1.1.1	G												
			Certification														
			SD-08 Manufacturer's Instructions														
			Manufacturer's Printed	2.1.1.2	G												
			Installation Instructions														
			Non-Shrink, Non-Metallic Grout	3.1.3	G												

SUBMITTAL REGISTER

CONTRACT NO.

TITLE AND LOCATION

LRSO Hardware Software Development Facility

CONTRACTOR

ACTIVITY NO	TRANSMITTAL NO	SPEC SECT	DESCRIPTION ITEM SUBMITTED	PARAGRAPH	CLASSIFICATION	CONTRACTOR: SCHEDULE DATES			CONTRACTOR ACTION		APPROVING AUTHORITY				MAILED TO CONTR/ DATE RCD FRM APPR AUTH	REMARKS		
						SUBMIT	APPROVAL NEEDED BY	MATERIAL NEEDED BY	ACTION CODE	DATE OF ACTION	DATE FWD TO APPR AUTH/	DATE RCD FROM CONTR	DATE FWD TO OTHER REVIEWER	DATE RCD FROM OTH REVIEWER			ACTION CODE	DATE OF ACTION
		05 05 20	Manufacturer's Material Safety Data Sheets	1.5														
		05 05 23.16	SD-01 Preconstruction Submittals															
			Welding Quality Assurance Plan	3.2	G													
			SD-03 Product Data															
			Welding Procedure Qualifications	1.3	G													
			Welder, Welding Operator, and Tacker Qualification	1.3.4														
			Previous Qualifications	1.3.2														
			Pre-Qualified Procedures	1.3.3	G													
			Welding Electrodes and Rods	2.2														
			SD-06 Test Reports															
			Nondestructive Testing	3.3														
			Weld Inspection Log	3.2														
			SD-07 Certificates															
			Certified Welding Procedure Specifications (WPS)	1.3.1														
			Certified Procedure Qualification Records (PQR)	1.3.1														
			Certified Welder Performance Qualifications (WPQ)	1.3.1														
			Certified Welding Inspector	1.3.5														
			Nondestructive Testing Personnel	1.3.5														
		05 30 00	SD-02 Shop Drawings															
			Fabrication Drawings	1.3.5	G													
			SD-03 Product Data															

SUBMITTAL REGISTER

CONTRACT NO.

TITLE AND LOCATION

LRSO Hardware Software Development Facility

CONTRACTOR

ACTIVITY NO	TRANSMITTAL NO	SPEC SECT	DESCRIPTION ITEM SUBMITTED	PARAGRAPH	GOVT CLASSIFICATION	CONTRACTOR: SCHEDULE DATES			CONTRACTOR ACTION		APPROVING AUTHORITY				MAILED TO CONTR/ DATE RCD FRM APPR AUTH	REMARKS		
						SUBMIT	APPROVAL NEEDED BY	MATERIAL NEEDED BY	ACTION CODE	DATE OF ACTION	DATE FWD TO APPR AUTH/	DATE RCD FROM CONTR	DATE FWD TO OTHER REVIEWER	DATE RCD FROM OTH REVIEWER			ACTION CODE	DATE OF ACTION
		05 30 00	Accessories	2.2														
			Deck Units	2.1														
			Galvanizing Repair Paint	2.1.3														
			Galvanizing Repair Paint	3.2.4.1														
			Mechanical Fasteners	2.2.11														
			Touch-Up Paint	2.1.3														
			Welding Equipment	1.3.3														
			Welding Rods and Accessories	1.3.3														
			Recycled Content of Steel Products	2.1	S													
			SD-04 Samples															
			Metal Roof Deck Units	2.1.1														
			Flexible Closure Strips	2.2.3														
			SD-05 Design Data															
			Deck Units	2.1	G													
			SD-07 Certificates															
			Powder-Actuated Tool Operator	1.3.2														
			Welder Qualifications	1.3.3														
			Welding Procedures	1.3.3														
			Fire Safety	1.3.4.1														
			Wind Storm Resistance	1.3.4.2														
			Manufacturer's Certificate	1.3.1														
		05 40 00	SD-02 Shop Drawings															
			Framing Components	1.5.1	G													
			SD-03 Product Data															
			Studs, Joists	2.1														

SUBMITTAL REGISTER

CONTRACT NO.

TITLE AND LOCATION

LRSO Hardware Software Development Facility

CONTRACTOR

ACTIVITY NO	TRANSMITTAL NO	SPEC SECT	DESCRIPTION ITEM SUBMITTED	PARAGRAPH	GOVT CLASSIFICATION	CONTRACTOR: SCHEDULE DATES			CONTRACTOR ACTION		APPROVING AUTHORITY				MAILED TO CONTR/ DATE RCD FRM APPR AUTH	REMARKS	
						SUBMIT	APPROVAL NEEDED BY	MATERIAL NEEDED BY	ACTION CODE	DATE OF ACTION	DATE FWD TO APPR AUTH/ DATE RCD FROM CONTR	DATE FWD TO OTHER REVIEWER	DATE RCD FROM OTH REVIEWER	ACTION CODE			DATE OF ACTION
		05 40 00	Recycled Content of Steel Products	2.1	S												
			SD-07 Certificates														
			Load-Bearing Cold-Formed Metal Framing	1.4													
			Welds	3.2.1													
		05 44 00	SD-02 Shop Drawings														
			Truss Design Drawings	1.8	G												
			Truss Design Drawings	3.2	G												
			Truss Placement Diagram	3.2	G												
			SD-03 Product Data														
			steel truss bracing, bridging, blocking, reinforcements, fasteners, and accessories	2.2	G												
			SD-05 Design Data														
			Truss Design Calculations	1.7	G												
			Installation Guidelines	3.2	G												
			SD-07 Certificates														
			Mill Certificates	1.8													
			Welds	2.2													
		05 50 13	SD-02 Shop Drawings														
			Structural Steel Door Frames	2.12	G												
			Cover Plates and Frames	2.5	G												
			Floor Gratings	2.6	G												
			Bollards/Pipe Guards	2.7	G												
			Angles and Plates	2.9	G												

SUBMITTAL REGISTER

CONTRACT NO.

TITLE AND LOCATION

LRSO Hardware Software Development Facility

CONTRACTOR

ACTIVITY NO	TRANSMITTAL NO	SPEC SECT	DESCRIPTION ITEM SUBMITTED	PARAGRAPH	GOVT CLASSIFICATION	CONTRACTOR: SCHEDULE DATES			CONTRACTOR ACTION		APPROVING AUTHORITY				MAILED TO CONTR/ DATE RCD FRM APPR AUTH	REMARKS		
						SUBMIT	APPROVAL NEEDED BY	MATERIAL NEEDED BY	ACTION CODE	DATE OF ACTION	DATE FWD TO APPR AUTH/ DATE RCD FROM CONTR	DATE FWD TO OTHER REVIEWER	DATE RCD FROM OTH REVIEWER	ACTION CODE			DATE OF ACTION	
																		(a)
		05 50 13	SD-03 Product Data															
			Corner Guards	2.4														
			Cover Plates and Frames	2.5	G													
			Floor Gratings	2.6	G													
			Structural Steel Door Frames	2.12	G													
			Downspout Terminations	2.8	G													
			Recycled Content	2.1	S													
			SD-07 Certificates															
			Certificates of Compliance	2.1	G													
			Certified Mill	2.2	G													
		06 10 00	SD-03 Product Data															
			Underlayment	2.4														
			Fire-retardant Treatment	1.8														
			Structural-use and OSB Panels	1.4.3														
			Oriented Strand Board	2.3														
			Adhesives	2.5.2														
			SD-07 Certificates															
			Certificates of Grade	1.11.1														
			Certified Sustainably Harvested Plywood for Other Uses	2.3.1.1	S													
			Preservative Treatment	1.7														
			Indoor Air Quality for Aerosol Adhesives	2.5.2	S													
			Indoor Air Quality for Non-aerosol Adhesives	2.5.2	S													
		06 12 13	SD-03 Product Data															

SUBMITTAL REGISTER

CONTRACT NO.

TITLE AND LOCATION

LRSO Hardware Software Development Facility

CONTRACTOR

ACTIVITY NO	TRANSMITTAL NO	SPEC SECT	DESCRIPTION ITEM SUBMITTED	PARAGRAPH	CLASSIFICATION	CONTRACTOR: SCHEDULE DATES			CONTRACTOR ACTION		APPROVING AUTHORITY				MAILED TO CONTR/ DATE RCD FRM APPR AUTH	REMARKS		
						SUBMIT	APPROVAL NEEDED BY	MATERIAL NEEDED BY	ACTION CODE	DATE OF ACTION	DATE FWD TO APPR AUTH/	DATE RCD FROM CONTR	DATE FWD TO OTHER REVIEWER	DATE RCD FROM OTH REVIEWER			ACTION CODE	DATE OF ACTION
		06 12 13	Product Data	2.2.1	G AE													
			SD-08 Manufacturer's Instructions															
			Material Safety Data	2.2.1	G													
			SD-10 Operation and Maintenance Data															
			Maintenance Manuals	2.2.1	G													
		06 41 16.00 10	SD-02 Shop Drawings															
			Shop Drawings	2.10	G AE													
			Installation	3.1	G													
			SD-03 Product Data															
			Wood Materials	2.1	G													
			Wood Finishes	2.9	G													
			Finish Schedule	2.10.7.3	G													
			Certification	1.5.2														
			SD-04 Samples															
			Plastic Laminates	2.3	G AE													
			Cabinet Hardware	2.6	G AE													
			SD-07 Certificates															
			Quality Assurance	1.5	G													
			Laminate Clad Casework	2.9	G													
			Laminate Clad Casework	3.1	G													
			SD-11 Closeout Submittals															
			LEED Documentation	1.3	S													
		06 61 16	SD-02 Shop Drawings															
			Installation	3.1	G													
			SD-03 Product Data															

SUBMITTAL REGISTER

CONTRACT NO.

TITLE AND LOCATION

LRSO Hardware Software Development Facility

CONTRACTOR

ACTIVITY NO	TRANSMITTAL NO	SPEC SECT	DESCRIPTION ITEM SUBMITTED	PARAGRAPH	GOVT CLASSIFICATION	CONTRACTOR: SCHEDULE DATES			CONTRACTOR ACTION		APPROVING AUTHORITY				MAILED TO CONTR/ DATE RCD FRM APPR AUTH	REMARKS	
						SUBMIT	APPROVAL NEEDED BY	MATERIAL NEEDED BY	ACTION CODE	DATE OF ACTION	DATE FWD TO APPR AUTH/ DATE RCD FROM CONTR	DATE FWD TO OTHER REVIEWER	DATE RCD FROM OTH REVIEWER	ACTION CODE			DATE OF ACTION
		06 61 16	Solid Polymer	2.1.1	G												
			Indoor air quality for solid surface seam and sealant products	2.2.2	S												
			SD-04 Samples														
			Material	2.1	G												
			Counter Tops	2.3.4	G												
			SD-06 Test Reports														
			Test Report Results	2.1.1													
			SD-07 Certificates														
			Qualifications	1.5.1													
			Indoor Air Quality for solid surface fabrication products	2.1.1	S												
			SD-10 Operation and Maintenance Data														
			Solid Polymer	2.1.1	G												
		07 14 00	SD-03 Product Data														
			Fluid-Applied Membrane	2.1													
			Membrane Primer	2.2													
			Elastomeric Sheet	2.6													
			Flexible Foam-Backed Elastomeric Sheet	2.8													
			Solvent	3.3													
			Moisture Meter	3.4.1													
			Bond Breaker	2.5													
			SD-11 Closeout Submittals														
			Warranty	1.6													

SUBMITTAL REGISTER

CONTRACT NO.

TITLE AND LOCATION

LRSO Hardware Software Development Facility

CONTRACTOR

ACTIVITY NO	TRANSMITTAL NO	SPEC SECT	DESCRIPTION ITEM SUBMITTED	PARAGRAPH	GOVT CLASSIFICATION	CONTRACTOR: SCHEDULE DATES			CONTRACTOR ACTION		APPROVING AUTHORITY				MAILED TO CONTR/ DATE RCD FRM APPR AUTH	REMARKS	
						SUBMIT	APPROVAL NEEDED BY	MATERIAL NEEDED BY	ACTION CODE	DATE OF ACTION	DATE FWD TO APPR AUTH/ DATE RCD FROM CONTR	DATE FWD TO OTHER REVIEWER	DATE RCD FROM OTH REVIEWER	ACTION CODE			DATE OF ACTION
		07 14 00	Information Card	3.5													
		07 21 16	SD-03 Product Data														
			Blanket Insulation	2.1	G												
			Recycled Content for Insulation Materials	2.1.1	S												
			Energy Star Label for Insulation Materials	2.1.2	S												
			Pressure Sensitive Tape	2.3													
			Accessories	2.4													
			SD-07 Certificates														
			Indoor Air Quality for Adhesives	2.4.1	S												
			SD-08 Manufacturer's Instructions														
			Insulation	3.3.1													
		07 22 00	SD-02 Shop Drawings														
			Insulation Board Layout	1.3	G												
			SD-03 Product Data														
			Insulation	2.1	G												
			Cover Board	1.4	G												
			Fasteners	2.3	G												
			Moisture Control	2.2	G												
			SD-06 Test Reports														
			Flame Spread Rating	1.7.1	G												
			SD-07 Certificates														
			Installer Qualifications	1.6	G												
			Acceptable Foam Blowing Agents	2.1.2	S												
			SD-08 Manufacturer's Instructions														

SUBMITTAL REGISTER

CONTRACT NO.

TITLE AND LOCATION
 LRSO Hardware Software Development Facility

CONTRACTOR

ACTIVITY NO	TRANSMITTAL NO	SPEC SECT	DESCRIPTION ITEM SUBMITTED	PARAGRAPH	GOVT CLASSIFICATION	CONTRACTOR: SCHEDULE DATES			CONTRACTOR ACTION		APPROVING AUTHORITY				MAILED TO CONTR/ DATE RCD FRM APPR AUTH	REMARKS		
						SUBMIT	APPROVAL NEEDED BY	MATERIAL NEEDED BY	ACTION CODE	DATE OF ACTION	DATE FWD TO APPR AUTH/	DATE RCD FROM CONTR	DATE FWD TO OTHER REVIEWER	DATE RCD FROM OTH REVIEWER			ACTION CODE	DATE OF ACTION
		07 22 00	Fasteners	2.3	G													
			Insulation	2.1	G													
		07 27 10	SD-02 Shop Drawings															
			Air Barrier System Shop Drawings	2.1	G													
			SD-03 Product Data															
			Air Barrier System Product Data	2.1	G													
			Material Samples For Air Barrier System	2.1	G													
			Manufacturer Data Sheet	2.2	G													
			SD-05 Design Data															
			Design Data And Calculations For The Air Barrier System	1.8	G													
			SD-06 Test Reports															
			Design Review Report	1.8	G													
			Testing and Inspection	3.1.2	G													
			SD-07 Certificates															
			Air Barrier Inspector	1.7	G RO													
		07 42 13	SD-01 Preconstruction Submittals															
			Qualification of Installation Contractor	1.5.1	G													
			Warranty	1.8	G													
			SD-03 Product Data															
			Factory Color Finish	2.3.1														
			Closure Materials	1.5.2														
			Sealants and Caulking	2.4.1.1														

SUBMITTAL REGISTER

CONTRACT NO.

TITLE AND LOCATION

LRSO Hardware Software Development Facility

CONTRACTOR

ACTIVITY NO	TRANSMITTAL NO	SPEC SECT	DESCRIPTION ITEM SUBMITTED	PARAGRAPH	GOVT CLASSIFICATION	CONTRACTOR: SCHEDULE DATES			CONTRACTOR ACTION		APPROVING AUTHORITY				MAILED TO CONTR/ DATE RCD FRM APPR AUTH	REMARKS		
						SUBMIT	APPROVAL NEEDED BY	MATERIAL NEEDED BY	ACTION CODE	DATE OF ACTION	DATE FWD TO APPR AUTH/ DATE RCD FROM CONTR	DATE FWD TO OTHER REVIEWER	DATE RCD FROM OTH REVIEWER	ACTION CODE			DATE OF ACTION	
																		(a)
		07 42 13	Accessories	1.5.2														
			Accessories	2.4														
			Soffits	2.2	G													
			Coating	2.3.1.6	G													
			SD-04 Samples															
			Wall Panels	2.1	G													
			Fasteners	2.1.2	G													
			Fasteners	2.1.2	G													
			SD-06 Test Reports															
			Leakage Tests	3.7.2	G													
			Chalking	2.3.1.6	G													
			SD-11 Closeout Submittals															
			Warranty	1.8	G													
			Maintenance Instructions	1.5.3	G													
			20 year 'No Dollar Limit' warranty for labor and material	1.8.1														
		07 60 00	SD-02 Shop Drawings															
			Exposed Sheet Metal	2.1.1	G													
			Gutters	3.1.12	G													
			Downspouts	3.1.13	G													
			Flashing at Roof Penetrations and Equipment Supports	3.1.18	G													
			Open Valley Flashing	3.1.14	G													
			Eave Flashing	3.1.15	G													
			SD-04 Samples															
			Finish Samples	1.4.2	G													

SUBMITTAL REGISTER

CONTRACT NO.

TITLE AND LOCATION

LRSO Hardware Software Development Facility

CONTRACTOR

ACTIVITY NO	TRANSMITTAL NO	SPEC SECT	DESCRIPTION ITEM SUBMITTED	PARAGRAPH	GOVT CLASSIFICATION	CONTRACTOR: SCHEDULE DATES			CONTRACTOR ACTION		APPROVING AUTHORITY				MAILED TO CONTR/ DATE RCD FRM APPR AUTH	REMARKS		
						SUBMIT	APPROVAL NEEDED BY	MATERIAL NEEDED BY	ACTION CODE	DATE OF ACTION	DATE FWD TO APPR AUTH/	DATE RCD FROM CONTR	DATE FWD TO OTHER REVIEWER	DATE RCD FROM OTH REVIEWER			ACTION CODE	DATE OF ACTION
		07 61 14.00 20	SD-02 Shop Drawings															
			Roofing	1.2.3	G													
			SD-03 Product Data															
			Roofing Panels	2.1	G													
			Energy Star Label for Steel	2.1	S													
			Roofing Product															
			Recycled Content for Steel	2.1.1	S													
			Roofing Product															
			Attachment Clips	2.3														
			Accessories	2.4														
			Fasteners	2.4.2														
			Sealants	2.4.3														
			Warranty	1.7	G													
			Downspout Terminations	2.5	G													
			SD-04 Samples															
			Panel	2.1														
			Sealants	2.4.3														
			Intermediate Support	2.2														
			SD-05 Design Data															
			Design Calculations	1.5														
			SD-06 Test Reports															
			Field Inspection	3.6														
			Structural Performance	1.3.3														
			Finish	1.6.6														
			SD-07 Certificates															

SUBMITTAL REGISTER

CONTRACT NO.

TITLE AND LOCATION

LRSO Hardware Software Development Facility

CONTRACTOR

ACTIVITY NO	TRANSMITTAL NO	SPEC SECT	DESCRIPTION ITEM SUBMITTED	PARAGRAPH	GOVT CLASSIFICATION	CONTRACTOR: SCHEDULE DATES			CONTRACTOR ACTION		APPROVING AUTHORITY				MAILED TO CONTR/ DATE RCD FRM APPR AUTH	REMARKS	
						SUBMIT	APPROVAL NEEDED BY	MATERIAL NEEDED BY	ACTION CODE	DATE OF ACTION	DATE FWD TO APPR AUTH/ DATE RCD FROM CONTR	DATE FWD TO OTHER REVIEWER	DATE RCD FROM OTH REVIEWER	ACTION CODE			DATE OF ACTION
		07 61 14.00 20	Manufacturer's Technical Representative	1.6.3													
			Installer's Qualifications	1.6.4													
			SD-08 Manufacturer's Instructions														
			Installation	3.3	G												
			SD-11 Closeout Submittals														
			Information Card	3.8													
			Warranty	1.7													
		07 84 00	SD-02 Shop Drawings														
			Firestopping System	2.1	G												
			SD-06 Test Reports														
			Inspection	3.3	G												
			SD-07 Certificates														
			Firestopping Materials	2.2													
			Installer Qualifications	1.5.1	G												
		08 11 13	SD-02 Shop Drawings														
			Doors	2.2	G AE												
			Doors	2.2	G AE												
			Frames	2.7	G AE												
			Frames	2.7	G AE												
			Accessories	2.5	G AE												
			SD-03 Product Data														
			Doors	2.2	G AE												
			Recycled Content for Steel Door Product	2.2	S												
			Frames	2.7	G AE												

SUBMITTAL REGISTER

CONTRACT NO.

TITLE AND LOCATION

LRSO Hardware Software Development Facility

CONTRACTOR

ACTIVITY NO	TRANSMITTAL NO	SPEC SECT	DESCRIPTION ITEM SUBMITTED	PARAGRAPH	GOVT CLASSIFICATION	CONTRACTOR: SCHEDULE DATES			CONTRACTOR ACTION		APPROVING AUTHORITY				MAILED TO CONTR/ DATE RCD FRM APPR AUTH	REMARKS	
						SUBMIT	APPROVAL NEEDED BY	MATERIAL NEEDED BY	ACTION CODE	DATE OF ACTION	DATE FWD TO APPR AUTH/ DATE RCD FROM CONTR	DATE FWD TO OTHER REVIEWER	DATE RCD FROM OTH REVIEWER	ACTION CODE			DATE OF ACTION
		08 11 13	Recycled Content for Steel Frame Product	2.7	S												
			Accessories	2.5	G AE												
		08 31 00	SD-02 Shop Drawings														
			Access Doors And Panels	1.3	G												
			SD-03 Product Data														
			Access Doors And Panels	1.3	G												
			Hardware	1.3.2	G												
			Accessories	2.2.8	G												
			Power Transfer Components	1.3.1	G												
			Recycled Content	2.1	S												
			SD-04 Samples														
			Finishes	2.5	G												
			SD-06 Test Reports														
			Fire-rating(s) of Assemblies	1.3.1	G												
			Acoustical Ratings of Assemblies	1.3.1	G												
		08 34 73	SD-02 Shop Drawings														
			Fabrication Drawings	2.1	G AE												
			SD-03 Product Data														
			Hollow Metal Sound Retardant Doors	2.1	G AE												
			Door Frames	2.1	G AE												
			Door Hardware	2.1	G AE												
			Door Frame Sound Infill	2.3.2	G AE												
			Thresholds	2.1	G AE												
			SD-06 Test Reports														

SUBMITTAL REGISTER

CONTRACT NO.

TITLE AND LOCATION

LRSO Hardware Software Development Facility

CONTRACTOR

ACTIVITY NO	TRANSMITTAL NO	SPEC SECT	DESCRIPTION ITEM SUBMITTED	PARAGRAPH	GOVT CLASSIFICATION	CONTRACTOR: SCHEDULE DATES			CONTRACTOR ACTION		APPROVING AUTHORITY				MAILED TO CONTR/ DATE RCD FRM APPR AUTH	REMARKS		
						SUBMIT	APPROVAL NEEDED BY	MATERIAL NEEDED BY	ACTION CODE	DATE OF ACTION	DATE FWD TO APPR AUTH/	DATE RCD FROM CONTR	DATE FWD TO OTHER REVIEWER	DATE RCD FROM OTH REVIEWER			ACTION CODE	DATE OF ACTION
		08 34 73	Wind Loading Tests	2.4.4	G AE													
			Water Leakage Tests	2.4.4	G AE													
			Acoustical Tests	2.4.4	G AE													
			Air Infiltration Tests	2.4.4	G AE													
			Positive Pressure Tests	2.4.4	G AE													
			SD-07 Certificates															
			Hollow Metal Sound Retardant Doors	2.1	G AE													
			Door Frames	2.1	G AE													
			Door Hardware	2.1	G AE													
			Thresholds	2.1	G													
			Assembly Test Reports	3.3.1														
		08 51 23	SD-02 Shop Drawings															
			Windows	2.2														
			Accessories	2.5														
			SD-03 Product Data															
			Steel Framing Materials	2.1.1														
			Recycled Content for Steel Framing Materials	2.1.1	S													
			Fasteners	2.5.2														
			SD-04 Samples															
			Color Coating	2.7.2	G													
			Windows	2.2														
			SD-10 Operation and Maintenance Data															
			Windows	2.2	G													

SUBMITTAL REGISTER

CONTRACT NO.

TITLE AND LOCATION

LRSO Hardware Software Development Facility

CONTRACTOR

ACTIVITY NO	TRANSMITTAL NO	SPEC SECT	DESCRIPTION ITEM SUBMITTED	PARAGRAPH	GOVT CLASSIFICATION	CONTRACTOR: SCHEDULE DATES			CONTRACTOR ACTION		APPROVING AUTHORITY				MAILED TO CONTR/ DATE RCD FRM APPR AUTH	REMARKS		
						SUBMIT	APPROVAL NEEDED BY	MATERIAL NEEDED BY	ACTION CODE	DATE OF ACTION	DATE FWD TO APPR AUTH/	DATE RCD FROM CONTR	DATE FWD TO OTHER REVIEWER	DATE RCD FROM OTH REVIEWER			ACTION CODE	DATE OF ACTION
		08 71 00	SD-02 Shop Drawings															
			Manufacturer's Detail Drawings	1.3	G AE													
			Verification of Existing Conditions	1.3	G AE													
			Hardware Schedule	1.5	G AE													
			Keying System	2.3.9	G AE													
			SD-03 Product Data															
			Hardware Items	2.3	G AE													
			Recycled Content	1.4	S													
			SD-08 Manufacturer's Instructions															
			Installation	3.1														
			SD-10 Operation and Maintenance Data															
			Hardware Schedule	1.5	G AE													
			SD-11 Closeout Submittals															
			Key Bitting	1.6.1	G													
		08 81 00	SD-03 Product Data															
			Insulating Glass	2.3														
			Sealants	2.4.3.1														
			SD-04 Samples															
			Insulating Glass	2.3														
			Glazing Compound	2.4.2														
			Tape	2.4.5														
			Sealing Tapes	2.4.5														
			SD-07 Certificates															
			Insulating Glass	2.3														
			SD-08 Manufacturer's Instructions															

SUBMITTAL REGISTER

CONTRACT NO.

TITLE AND LOCATION

LRSO Hardware Software Development Facility

CONTRACTOR

ACTIVITY NO	TRANSMITTAL NO	SPEC SECT	DESCRIPTION ITEM SUBMITTED	PARAGRAPH	GOVT CLASSIFICATION	CONTRACTOR: SCHEDULE DATES			CONTRACTOR ACTION		APPROVING AUTHORITY				MAILED TO CONTR/ DATE RCD FRM APPR AUTH	REMARKS		
						SUBMIT	APPROVAL NEEDED BY	MATERIAL NEEDED BY	ACTION CODE	DATE OF ACTION	DATE FWD TO APPR AUTH/	DATE RCD FROM CONTR	DATE FWD TO OTHER REVIEWER	DATE RCD FROM OTH REVIEWER			ACTION CODE	DATE OF ACTION
		08 81 00	Setting and Sealing Materials	2.4														
			Glass Setting	3.2														
			SD-11 Closeout Submittals															
			Insulated Glass Units	1.6.1														
		08 91 00	SD-02 Shop Drawings															
			Wall Louvers	1.4	G AE													
			SD-03 Product Data															
			Metal Wall Louvers	2.2	G AE													
			SD-04 Samples															
			Wall Louver Samples	1.5	G AE													
		09 29 00	SD-03 Product Data															
			Cementitious Backer Units	2.1.7	G AE													
			Glass Mat Water-Resistant	2.1.4														
			Gypsum Tile Backing Board															
			Water-Resistant Gypsum Backing Board	2.1.3	G AE													
			Glass Mat Covered or Reinforced Gypsum Sheathing	2.1.5	G AE													
			Glass Mat Covered or Reinforced Gypsum Sheathing Sealant	2.1.5.1	G AE													
			Abuse Resistant Gypsum Board	2.1.6	G AE													
			Accessories	2.1.11	G AE													
			Gypsum Board	2.1.1	G AE													
			Recycled Content for Gypsum Board	2.1.1	S													

SUBMITTAL REGISTER

CONTRACT NO.

TITLE AND LOCATION

LRSO Hardware Software Development Facility

CONTRACTOR

ACTIVITY NO	TRANSMITTAL NO	SPEC SECT	DESCRIPTION ITEM SUBMITTED	PARAGRAPH	GOVT CLASSIFICATION	CONTRACTOR: SCHEDULE DATES			CONTRACTOR ACTION		APPROVING AUTHORITY				MAILED TO CONTR/ DATE RCD FRM APPR AUTH	REMARKS	
						SUBMIT	APPROVAL NEEDED BY	MATERIAL NEEDED BY	ACTION CODE	DATE OF ACTION	DATE FWD TO APPR AUTH/ DATE RCD FROM CONTR	DATE FWD TO OTHER REVIEWER	DATE RCD FROM OTH REVIEWER	ACTION CODE			DATE OF ACTION
		09 29 00	Recycled Content for Paper Facing and Gypsum Cores	2.1.1	S												
			VOC Content of Joint Compound	2.1.8	S												
			SD-06 Test Reports														
			Asbestos Free Materials	2.1	G												
			Indoor Air Quality for Gypsum Board	2.1.1	S												
			Indoor Air Quality for Non-aerosol Adhesives	2.1.10	S												
			Indoor Air Quality for Aerosol Adhesives	2.1.10	S												
			SD-08 Manufacturer's Instructions														
			Safety Data Sheets	2.1													
			SD-10 Operation and Maintenance Data														
			Manufacturer Maintenance Instructions	2.1													
		09 30 10	SD-02 Shop Drawings														
			Detail Drawings	3.2	G												
			SD-03 Product Data														
			Porcelain Tile	2.1.1	G												
			Recycled Content for Porcelain Tile	2.1.1	S												
			Mosaic Tile	2.1.2	G												
			Recycled Content for Mosaic Tile	2.1.2	S												
			Glazed Ceramic Wall Tile	2.1.3	G												

SUBMITTAL REGISTER

CONTRACT NO.

TITLE AND LOCATION
 LRSO Hardware Software Development Facility

CONTRACTOR

ACTIVITY NO	TRANSMITTAL NO	SPEC SECT	DESCRIPTION ITEM SUBMITTED	PARAGRAPH	GOVT CLASSIFICATION	CONTRACTOR: SCHEDULE DATES			CONTRACTOR ACTION		APPROVING AUTHORITY				MAILED TO CONTR/ DATE RCD FRM APPR AUTH	REMARKS		
						SUBMIT	APPROVAL NEEDED BY	MATERIAL NEEDED BY	ACTION CODE	DATE OF ACTION	DATE FWD TO APPR AUTH/	DATE RCD FROM CONTR	DATE FWD TO OTHER REVIEWER	DATE RCD FROM OTH REVIEWER			ACTION CODE	DATE OF ACTION
		09 30 10	Recycled Content for Glazed Ceramic Wall Tile	2.1.3	S													
			Transition Strips	2.1	G													
			Transition Strips	2.6.1	G													
			Metal Strips	2.6.2	G													
			Setting-Bed	2.2	G													
			Mortar, Grout, and Adhesive	2.4	G													
			Cementitious Backer Units	2.5.1	G													
			Glass-Mat Gypsum	2.5.2	G													
			Water-Resistant Backing Board															
			Waterproof Membrane	2.7	G													
			Crack Isolation Membrane	2.8	G													
			SD-04 Samples															
			Tile	2.1	G													
			Accessories	2.1	G													
			Transition Strips	2.1	G													
			Transition Strips	2.6.1	G													
			Metal Strips	2.6.2	G													
			Grout	2.4.4	G													
			SD-07 Certificates															
			Indoor Air Quality for Adhesives	2.4	S													
			Indoor Air Quality for Sealants	2.4.9	S													
			Water Absorption Rates	1.3.2														
			SD-08 Manufacturer's Instructions															
			Manufacturer's Approved Cleaning Instructions	3.8														

SUBMITTAL REGISTER

CONTRACT NO.

TITLE AND LOCATION

LRSO Hardware Software Development Facility

CONTRACTOR

ACTIVITY NO	TRANSMITTAL NO	SPEC SECT	DESCRIPTION ITEM SUBMITTED	PARAGRAPH	GOVT CLASSIFICATION	CONTRACTOR: SCHEDULE DATES			CONTRACTOR ACTION		APPROVING AUTHORITY				MAILED TO CONTR/ DATE RCD FRM APPR AUTH	REMARKS		
						SUBMIT	APPROVAL NEEDED BY	MATERIAL NEEDED BY	ACTION CODE	DATE OF ACTION	DATE FWD TO APPR AUTH/	DATE RCD FROM CONTR	DATE FWD TO OTHER REVIEWER	DATE RCD FROM OTH REVIEWER			ACTION CODE	DATE OF ACTION
		09 30 10	SD-10 Operation and Maintenance Data															
			Porcelain Tile	2.1.1	G													
			Mosaic Tile	2.1.2	G													
			Glazed Ceramic Wall Tile	2.1.3	G													
			Transition Strips	2.1	G													
			Transition Strips	2.6.1	G													
			Metal Strips	2.6.2	G													
		09 62 38	SD-03 Product Data															
			Static-Control Resilient Flooring	2.1	G AE													
			Recycled content for Conductive Vinyl Tile	2.1.1.1	S													
			Accessories	2.4	G													
			Adhesives	2.2	G													
			Warranty	1.9														
			SD-04 Samples															
			Static-Control Resilient Flooring	2.1	G AE													
			Moldings	2.3	G													
			Accessories	2.4	G													
			SD-06 Test Reports															
			Fire Resistance	2.7														
			Moisture, Alkalinity and Bond	3.2														
			Testing	3.7														
			SD-07 Certificates															
			Indoor Air Quality for Conductive Vinyl Tile	2.1.1.1	S													

SUBMITTAL REGISTER

CONTRACT NO.

TITLE AND LOCATION

LRSO Hardware Software Development Facility

CONTRACTOR

ACTIVITY NO	TRANSMITTAL NO	SPEC SECT	DESCRIPTION ITEM SUBMITTED	PARAGRAPH	GOVT CLASSIFICATION	CONTRACTOR: SCHEDULE DATES			CONTRACTOR ACTION		APPROVING AUTHORITY				MAILED TO CONTR/ DATE RCD FRM APPR AUTH	REMARKS		
						SUBMIT	APPROVAL NEEDED BY	MATERIAL NEEDED BY	ACTION CODE	DATE OF ACTION	DATE FWD TO APPR AUTH/	DATE RCD FROM CONTR	DATE FWD TO OTHER REVIEWER	DATE RCD FROM OTH REVIEWER			ACTION CODE	DATE OF ACTION
		09 62 38	Indoor Air Quality for Adhesives	2.2	S													
			Qualifications of Applicator	1.6														
			SD-08 Manufacturer's Instructions															
			Static-Control Resilient Flooring	2.1	G													
			Accessories	2.4	G													
			SD-10 Operation and Maintenance Data															
			Static-Control Resilient Flooring	2.1	G													
			Accessories	2.4	G													
		09 65 00	SD-02 Shop Drawings															
			Resilient Flooring and Accessories	2.8	G													
			SD-03 Product Data															
			Resilient Flooring and Accessories	2.8	G													
			Adhesives	2.4														
			Luxury Vinyl Tile	2.1														
			Recycled content for Luxury Vinyl Tile	2.1	S													
			Wall Base	2.2														
			SD-04 Samples															
			Resilient Flooring and Accessories	2.8	G													
			SD-06 Test Reports															
			Moisture, Alkalinity and Bond Tests	3.3	G													

SUBMITTAL REGISTER

CONTRACT NO.

TITLE AND LOCATION

LRSO Hardware Software Development Facility

CONTRACTOR

ACTIVITY NO	TRANSMITTAL NO	SPEC SECT	DESCRIPTION ITEM SUBMITTED	PARAGRAPH	GOVT CLASSIFICATION	CONTRACTOR: SCHEDULE DATES			CONTRACTOR ACTION		APPROVING AUTHORITY				MAILED TO CONTR/ DATE RCD FRM APPR AUTH	REMARKS		
						SUBMIT	APPROVAL NEEDED BY	MATERIAL NEEDED BY	ACTION CODE	DATE OF ACTION	DATE FWD TO APPR AUTH/	DATE RCD FROM CONTR	DATE FWD TO OTHER REVIEWER	DATE RCD FROM OTH REVIEWER			ACTION CODE	DATE OF ACTION
		09 65 00	SD-07 Certificates															
			Indoor Air Quality for Luxury Vinyl Tile	2.1	S													
			Indoor Air Quality for Wall Base	2.2	S													
			Indoor Air Quality for Adhesives	2.4	S													
			SD-08 Manufacturer's Instructions															
			Surface Preparation	3.2	G													
			Installation	3.1	G													
			SD-10 Operation and Maintenance Data															
			Resilient Flooring and Accessories	2.8	G													
		09 67 23.14	SD-02 Shop Drawings															
			Flooring Systems	2.2	G													
			SD-03 Product Data															
			Sealer and Resin	2.4	G AE													
			Floor Surfacing	3.3.2	G AE													
			Conductive Sparkproof Flooring	2.3	G AE													
			Indoor Air Quality for Primer	2.1.1	S													
			Indoor Air Quality for Top Coating	2.1.5	S													
			Indoor Air Quality for Sealer And Resin	2.4	S													
			Mixing	3.2	G													
			SD-04 Samples															
			Flooring Systems	2.2	G AE													
			SD-06 Test Reports															

SUBMITTAL REGISTER

CONTRACT NO.

TITLE AND LOCATION

LRSO Hardware Software Development Facility

CONTRACTOR

ACTIVITY NO	TRANSMITTAL NO	SPEC SECT	DESCRIPTION ITEM SUBMITTED	PARAGRAPH	GOVT CLASSIFICATION	CONTRACTOR: SCHEDULE DATES			CONTRACTOR ACTION		APPROVING AUTHORITY				MAILED TO CONTR/ DATE RCD FRM APPR AUTH	REMARKS	
						SUBMIT	APPROVAL NEEDED BY	MATERIAL NEEDED BY	ACTION CODE	DATE OF ACTION	DATE FWD TO APPR AUTH/ DATE RCD FROM CONTR	DATE FWD TO OTHER REVIEWER	DATE RCD FROM OTH REVIEWER	ACTION CODE			DATE OF ACTION
		09 67 23.14	Testing	3.4	G												
			SD-07 Certificates														
			Qualifications of Installer	1.3.1	G												
			SD-08 Manufacturer's Instructions														
			Application	3.3	G												
			SD-10 Operation and Maintenance Data														
			Flooring Systems	2.2	G												
		09 68 00	SD-02 Shop Drawings														
			Installation Drawings	3.4	G												
			SD-03 Product Data														
			Carpet	2.1	G												
			Recycled Content for Carpeting	2.1.1	S												
			Moldings	2.4	G												
			Indoor Air Quality for Aerosol Adhesives	2.3	S												
			Indoor Air Quality for Non-Aerosol Adhesives	2.3	S												
			Indoor Air Quality for Concrete Primer	2.3	S												
			SD-04 Samples														
			Carpet	2.1	G												
			Moldings	2.4	G												
			SD-06 Test Reports														
			Moisture and Alkalinity Tests	3.2	G												
			SD-07 Certificates														

SUBMITTAL REGISTER

CONTRACT NO.

TITLE AND LOCATION

LRSO Hardware Software Development Facility

CONTRACTOR

ACTIVITY NO	TRANSMITTAL NO	SPEC SECT	DESCRIPTION ITEM SUBMITTED	PARAGRAPH	GOVT CLASSIFICATION	CONTRACTOR: SCHEDULE DATES			CONTRACTOR ACTION		APPROVING AUTHORITY				MAILED TO CONTR/ DATE RCD FRM APPR AUTH	REMARKS	
						SUBMIT	APPROVAL NEEDED BY	MATERIAL NEEDED BY	ACTION CODE	DATE OF ACTION	DATE FWD TO APPR AUTH/ DATE RCD FROM CONTR	DATE FWD TO OTHER REVIEWER	DATE RCD FROM OTH REVIEWER	ACTION CODE			DATE OF ACTION
		09 68 00	Indoor Air Quality for Carpet	2.1.2	S												
			SD-08 Manufacturer's Instructions														
			Surface Preparation	3.1													
			SD-10 Operation and Maintenance Data														
			Cleaning and Protection	3.6													
			SD-11 Closeout Submittals														
			Warranty	1.6													
		09 69 13	SD-02 Shop Drawings														
			Detailed Installation Drawings	2.2.2	G AE												
			Fabrication Drawings	2.2.1	G AE												
			SD-03 Product Data														
			Access Flooring System	2.1	G AE												
			Recycled Content of Access Flooring System	2.1.1	S												
			Indoor Air Quality For Pedestal Adhesive	2.1.5	S												
			Indoor Air Quality For Adhesives	2.2.6	S												
			SD-04 Samples														
			Floor Panels	2.2													
			Floor Covering	2.2.4	G												
			Panel Support System	2.3	G AE												
			Cut Outs	2.6	G AE												
			SD-06 Test Reports														
			Factory Tests	2.4													
			Concentrated Load	2.1.1													

SUBMITTAL REGISTER

CONTRACT NO.

TITLE AND LOCATION

LRSO Hardware Software Development Facility

CONTRACTOR

ACTIVITY NO	TRANSMITTAL NO	SPEC SECT	DESCRIPTION ITEM SUBMITTED	PARAGRAPH	GOVT CLASSIFICATION	CONTRACTOR: SCHEDULE DATES			CONTRACTOR ACTION		APPROVING AUTHORITY				MAILED TO CONTR/ DATE RCD FRM APPR AUTH	REMARKS	
						SUBMIT	APPROVAL NEEDED BY	MATERIAL NEEDED BY	ACTION CODE	DATE OF ACTION	DATE FWD TO APPR AUTH/ DATE RCD FROM CONTR	DATE FWD TO OTHER REVIEWER	DATE RCD FROM OTH REVIEWER	ACTION CODE			DATE OF ACTION
		09 69 13	Uniform Live Load	2.1.1													
			Rolling Load	2.1.1													
			Rolling Load	2.1.1													
			Impact Load	2.1.1													
			Ultimate Load	2.1.1													
			Stringer Load	2.1.3													
			Pedestal Axial Load	2.1.4													
			Bonding Strength of Pedestal Adhesive	2.1.5													
			Electrical Resistance	3.2.4													
			Field Tests	3.2													
			SD-07 Certificates														
			Compliance with ICC-ES AC308	2.1													
			Compliance with ICC IBC	2.1													
			Certificate of Compliance	2.1													
			Qualification of Manufacturer	1.4.1													
			SD-10 Operation and Maintenance Data														
			Operation and Maintenance Manuals	3.4	G												
			SD-11 Closeout Submittals														
			Lifting Device	2.2.7													
			Warranty	1.6	G												
		09 90 00	SD-02 Shop Drawings														
			Piping Identification	3.10													
			SD-03 Product Data														

SUBMITTAL REGISTER

CONTRACT NO.

TITLE AND LOCATION

LRSO Hardware Software Development Facility

CONTRACTOR

ACTIVITY NO	TRANSMITTAL NO	SPEC SECT	DESCRIPTION ITEM SUBMITTED	PARAGRAPH	GOVT CLASSIFICATION	CONTRACTOR: SCHEDULE DATES			CONTRACTOR ACTION		APPROVING AUTHORITY				MAILED TO CONTR/ DATE RCD FRM APPR AUTH	REMARKS		
						SUBMIT	APPROVAL NEEDED BY	MATERIAL NEEDED BY	ACTION CODE	DATE OF ACTION	DATE FWD TO APPR AUTH/	DATE RCD FROM CONTR	DATE FWD TO OTHER REVIEWER	DATE RCD FROM OTH REVIEWER			ACTION CODE	DATE OF ACTION
		09 90 00	Coating	2.1	G													
			Product Data Sheets	2.1														
			SD-04 Samples															
			Color	2.2	G													
			SD-07 Certificates															
			Qualification Testing	1.6.5.2	G													
			Indoor Air Quality for Paints and Primers	1.6.4														
			Indoor Air Quality for Consolidated Latex Paints	1.6.4														
			SD-08 Manufacturer's Instructions															
			Mixing	2.1														
			Manufacturer's Safety Data Sheets	1.8.1														
			SD-10 Operation and Maintenance Data															
			Coatings	2.1	G													
		10 11 00	SD-02 Shop Drawings															
			Placement Schedule	3.1	G													
			SD-03 Product Data															
			Visual Display Unit	1.2	G													
			Visual Display Unit	2.1	G													
			SD-04 Samples															
			Aluminum	2.1.1	G													
			Glass	2.1.2	G													
			SD-07 Certificates															

SUBMITTAL REGISTER

CONTRACT NO.

TITLE AND LOCATION

LRSO Hardware Software Development Facility

CONTRACTOR

ACTIVITY NO	TRANSMITTAL NO	SPEC SECT	DESCRIPTION ITEM SUBMITTED	PARAGRAPH	GOVT CLASSIFICATION	CONTRACTOR: SCHEDULE DATES			CONTRACTOR ACTION		APPROVING AUTHORITY				MAILED TO CONTR/ DATE RCD FRM APPR AUTH	REMARKS		
						SUBMIT	APPROVAL NEEDED BY	MATERIAL NEEDED BY	ACTION CODE	DATE OF ACTION	DATE FWD TO APPR AUTH/	DATE RCD FROM CONTR	DATE FWD TO OTHER REVIEWER	DATE RCD FROM OTH REVIEWER			ACTION CODE	DATE OF ACTION
		10 11 00	Indoor air quality for markerboards	2.2.1	S													
			Certificate of Compliance	1.2														
			SD-08 Manufacturer's Instructions															
			Manufacturer's Cleaning Instructions	3.3														
			Manufacturer's Printed Installation Instructions	3.2	G													
		10 14 00.10	SD-02 Shop Drawings															
			Approved Detail Drawings	3.1	G AE													
			SD-03 Product Data															
			Modular Exterior Signage System Installation	2.1	G AE													
			Exterior Signage	3.1														
			Wind Load Requirements	1.2	G													
			SD-04 Samples	1.2.1														
			Exterior Signage	1.2	G AE													
			SD-10 Operation and Maintenance Data															
			Protection and Cleaning	3.1.2	G													
		10 14 00.20	SD-02 Shop Drawings															
			Detail Drawings	1.4.2	G													
			SD-03 Product Data															
			Room Identification And Directional Signage System	2.1	G													
			Exit Door Tactile Sign	2.2	G													

SUBMITTAL REGISTER

CONTRACT NO.

TITLE AND LOCATION

LRSO Hardware Software Development Facility

CONTRACTOR

ACTIVITY NO	TRANSMITTAL NO	SPEC SECT	DESCRIPTION ITEM SUBMITTED	PARAGRAPH	GOVT CLASSIFICATION	CONTRACTOR: SCHEDULE DATES			CONTRACTOR ACTION		APPROVING AUTHORITY					REMARKS			
						SUBMIT	APPROVAL NEEDED BY	MATERIAL NEEDED BY	ACTION CODE	DATE OF ACTION	DATE FWD TO APPR AUTH/	DATE RCD FROM CONTR	DATE FWD TO OTHER REVIEWER	DATE RCD FROM OTH REVIEWER	ACTION CODE		DATE OF ACTION	MAILED TO CONTR/	DATE RCD FRM APPR AUTH
		10 14 00.20	Door Tags	2.3	G														
			SD-04 Samples																
			Interior Signage	1.4.1	G														
			Software	1.3	G														
			Room Identification And Directional Signage System	2.1	G														
			Exit Door Tactile Sign	2.2	G														
			SD-10 Operation and Maintenance Data																
			Approved Manufacturer's Instructions	3.2	G														
			Protection and Cleaning	3.2.2	G														
		10 21 13	SD-02 Shop Drawings																
			Fabrication Drawings	2.1															
			Installation Drawings	3.3	G														
			SD-03 Product Data																
			Cleaning and Maintenance Instructions	2.1															
			Colors And Finishes	2.8															
			Anchoring Devices and Fasteners	2.2.2															
			Hardware and Fittings	2.2.4															
			Brackets	2.2.3															
			Door Hardware	2.2.5															
			Toilet Enclosures	2.3.1															
			Pilaster Shoes	2.6															
			Finishes	2.2.4.2	G														

SUBMITTAL REGISTER

CONTRACT NO.

TITLE AND LOCATION

LRSO Hardware Software Development Facility

CONTRACTOR

ACTIVITY NO	TRANSMITTAL NO	SPEC SECT	DESCRIPTION ITEM SUBMITTED	PARAGRAPH	GOVT CLASSIFICATION	CONTRACTOR: SCHEDULE DATES			CONTRACTOR ACTION		APPROVING AUTHORITY				MAILED TO CONTR/ DATE RCD FRM APPR AUTH	REMARKS		
						SUBMIT	APPROVAL NEEDED BY	MATERIAL NEEDED BY	ACTION CODE	DATE OF ACTION	DATE FWD TO APPR AUTH/ DATE RCD FROM CONTR	DATE FWD TO OTHER REVIEWER	DATE RCD FROM OTH REVIEWER	ACTION CODE			DATE OF ACTION	
																		(g)
		10 21 13	Finishes	2.8.2	G													
			Recycled content for solid phenolic partitions and screens	2.3	S													
			SD-04 Samples															
			Colors and Finishes	2.8	G													
			Hardware and Fittings	2.2.4														
			Anchoring Devices and Fasteners	2.2.2														
			SD-07 Certificates															
			Warranty	1.6														
			Indoor air quality for solid phenolic, through-color partitions and screens	2.3	S													
		10 26 00	SD-02 Shop Drawings															
			Corner Guards	2.2	G													
			Wall Covering and Panels	2.3	G													
			SD-03 Product Data															
			Corner Guards	2.2	G													
			Wall Covering and Panels	2.3	G													
			Recycled content for aluminum component of corner guards	2.2.1	S													
			Recycled content for steel component of corner guards	2.2.2	S													
			SD-04 Samples															
			Corner Guards	2.2	G													
			Wall Covering and Panels	2.3	G													
			SD-06 Test Reports															

SUBMITTAL REGISTER

CONTRACT NO.

TITLE AND LOCATION

LRSO Hardware Software Development Facility

CONTRACTOR

ACTIVITY NO	TRANSMITTAL NO	SPEC SECT	DESCRIPTION ITEM SUBMITTED	PARAGRAPH	GOVT CLASSIFICATION	CONTRACTOR: SCHEDULE DATES			CONTRACTOR ACTION		APPROVING AUTHORITY				MAILED TO CONTR/ DATE RCD FRM APPR AUTH	REMARKS		
						SUBMIT	APPROVAL NEEDED BY	MATERIAL NEEDED BY	ACTION CODE	DATE OF ACTION	DATE FWD TO APPR AUTH/	DATE RCD FROM CONTR	DATE FWD TO OTHER REVIEWER	DATE RCD FROM OTH REVIEWER			ACTION CODE	DATE OF ACTION
		10 26 00	Fire Resistance Rating SD-07 Certificates	2.1.1.2														
			Indoor air quality for wall covering/panels	2.3	S													
			Indoor air quality for adhesives	2.6	S													
			SD-10 Operation and Maintenance Data															
			Corner Guards	2.2	G													
			Wall Covering and Panels	2.3	G													
		10 28 13	SD-02 Shop Drawings															
			Product Schedule	2.1	G													
			SD-03 Product Data															
			Recycled content for stainless steel toilet accessories	2.1	S													
			Finishes	2.1.2	G AE													
			Accessory Items	2.1	G													
			SD-10 Operation and Maintenance Data															
			Accessory Items	2.1	G													
		10 44 16	SD-02 Shop Drawings															
			Fire Extinguishers	2.1.1	G AE													
			Accessories	Part 2	G AE													
			Cabinets	Part 2	G AE													
			Wall Brackets	2.2.2	G													
			Schedule	1.5	G													
			SD-03 Product Data															

SUBMITTAL REGISTER

CONTRACT NO.

TITLE AND LOCATION

LRSO Hardware Software Development Facility

CONTRACTOR

ACTIVITY NO	TRANSMITTAL NO	SPEC SECT	DESCRIPTION ITEM SUBMITTED	PARAGRAPH	GOVT CLASSIFICATION	CONTRACTOR: SCHEDULE DATES			CONTRACTOR ACTION		APPROVING AUTHORITY				MAILED TO CONTR/ DATE RCD FRM APPR AUTH	REMARKS		
						SUBMIT	APPROVAL NEEDED BY	MATERIAL NEEDED BY	ACTION CODE	DATE OF ACTION	DATE FWD TO APPR AUTH/	DATE RCD FROM CONTR	DATE FWD TO OTHER REVIEWER	DATE RCD FROM OTH REVIEWER			ACTION CODE	DATE OF ACTION
		10 44 16	Fire Extinguishers	2.1.1	G AE													
			Accessories	Part 2	G AE													
			Cabinets	Part 2	G													
			Wall Brackets	2.2.2	G													
			Replacement Parts List	3.2.1	G													
			SD-04 Samples															
			Equipment Samples	1.3.1	G AE													
			SD-07 Certificates															
			Fire Extinguishers Certifications	2.1.1	G													
			Manufacturer's Warranty with Inspection Tag	1.4	G													
		10 51 13	SD-02 Shop Drawings															
			Types	2.1	G AE													
			Location	1.4	G													
			Installation	3.1														
			Numbering system	3.2														
			SD-03 Product Data															
			Material	2.2														
			Locking Devices	2.3.1														
			Lock Control Chart	2.3.1														
			Finish	2.2.2														
			components	2.3														
			Assembly	3.1														
			SD-04 Samples															
			Color chips	1.5.1	G AE													
		11 13 19.23	SD-02 Shop Drawings															

SUBMITTAL REGISTER

CONTRACT NO.

TITLE AND LOCATION

LRSO Hardware Software Development Facility

CONTRACTOR

ACTIVITY NO	TRANSMITTAL NO	SPEC SECT	DESCRIPTION ITEM SUBMITTED	PARAGRAPH	GOVT CLASSIFICATION	CONTRACTOR: SCHEDULE DATES			CONTRACTOR ACTION		APPROVING AUTHORITY				MAILED TO CONTR/ DATE RCD FRM APPR AUTH	REMARKS	
						SUBMIT	APPROVAL NEEDED BY	MATERIAL NEEDED BY	ACTION CODE	DATE OF ACTION	DATE FWD TO APPR AUTH/ DATE RCD FROM CONTR	DATE FWD TO OTHER REVIEWER	DATE RCD FROM OTH REVIEWER	ACTION CODE			DATE OF ACTION
		11 13 19.23	Dock Equipment	2.2													
			Dock Equipment	2.2.4													
			SD-03 Product Data														
			Dock Equipment	2.2													
			Dock Equipment	2.2.4													
			Hydraulic Dock Lift	2.2													
			Remote Located Control Station	2.2.4.5.1													
			SD-05 Design Data														
			Electrical Requirements	2.2.4.5.1													
			SD-08 Manufacturer's Instructions														
			Safety Devices	2.2.4.6													
			SD-10 Operation and Maintenance Data														
			Operating Manuals	2.2.4.5.1													
			Maintenance Data	2.2.4.5.1													
		12 48 13	SD-02 Shop Drawings														
			Installation Drawings	3.2	G												
			Detail Drawings	3.2	G AE												
			SD-03 Product Data														
			Entrance Floor Mats	2.1.1	G AE												
			Adhesives and Concrete Primers	2.1.2	G												
			SD-04 Samples														
			Entrance Floor Mats	2.1.1	G AE												
			SD-08 Manufacturer's Instructions														
			Manufacturer's Instructions	3.2													

SUBMITTAL REGISTER

CONTRACT NO.

TITLE AND LOCATION

LRSO Hardware Software Development Facility

CONTRACTOR

ACTIVITY NO	TRANSMITTAL NO	SPEC SECT	DESCRIPTION ITEM SUBMITTED	PARAGRAPH	GOVT CLASSIFICATION	CONTRACTOR: SCHEDULE DATES			CONTRACTOR ACTION		APPROVING AUTHORITY				MAILED TO CONTR/ DATE RCD FRM APPR AUTH	REMARKS	
						SUBMIT	APPROVAL NEEDED BY	MATERIAL NEEDED BY	ACTION CODE	DATE OF ACTION	DATE FWD TO APPR AUTH/ DATE RCD FROM CONTR	DATE FWD TO OTHER REVIEWER	DATE RCD FROM OTH REVIEWER	ACTION CODE			DATE OF ACTION
		12 48 13	SD-10 Operation and Maintenance Data														
			Protection, Maintenance, and Repair Information	3.2													
		12 50 00.13 10	SD-01 Preconstruction Submittals														
			Storage Location	1.7.3	G												
			SD-02 Shop Drawings														
			Installation Drawings	3.3.1	G												
			Grommet, Power and Communication Units, and Wire Management Locations	3.3.1	G												
			SD-03 Product Data														
			Product Data	2.3	G												
			Product Style Options	2.3	G												
			SD-04 Samples														
			Fabric and Finishes	2.3.6	G												
			SD-07 Certificates														
			Authorized Dealer	1.6	G												
			Certified Furniture Installers	1.6	G												
			Licensed Electrician	1.6	G												
			Certified Telecommunications Installer	1.6	G												
			Manufacturer's Certification	2.3	G												
			Warranty	1.8	G												
			SD-10 Operation and Maintenance Data														

SUBMITTAL REGISTER

CONTRACT NO.

TITLE AND LOCATION

LRSO Hardware Software Development Facility

CONTRACTOR

ACTIVITY NO	TRANSMITTAL NO	SPEC SECT	DESCRIPTION ITEM SUBMITTED	PARAGRAPH	GOVT CLASSIFICATION	CONTRACTOR: SCHEDULE DATES			CONTRACTOR ACTION		APPROVING AUTHORITY				MAILED TO CONTR/ DATE RCD FRM APPR AUTH	REMARKS		
						SUBMIT	APPROVAL NEEDED BY	MATERIAL NEEDED BY	ACTION CODE	DATE OF ACTION	DATE FWD TO APPR AUTH/	DATE RCD FROM CONTR	DATE FWD TO OTHER REVIEWER	DATE RCD FROM OTH REVIEWER			ACTION CODE	DATE OF ACTION
		12 50 00.13 10	Furniture, Data Package 1	3.5	G													
			SD-11 Closeout Submittals															
			Energy Efficient Equipment	2.1.1	S													
			Reduced VOC's for Furniture	2.1.2	S													
			Recycled Content of Furniture	2.1.3	S													
			Bio-Based Content of Furniture	2.1.4	S													
		12 59 00	SD-02 Shop Drawings															
			Detail Drawings	1.4.3	G													
			SD-03 Product Data															
			Warranty	1.6	G													
			Workstations	2.2.1														
			Power and Communications	2.11														
			Recycled Content for system furniture components	2.1	S													
			SD-04 Samples															
			Workstations	2.2.1	G													
			Samples	2.2.2														
			SD-06 Test Reports															
			Selected Components	2.2.4.1	G													
			Panel Acoustics	2.2.4.2	G													
			Fire Safety	1.4.2	G													
			SD-07 Certificates															
			Workstations	2.2.1	S													
			SD-10 Operation and Maintenance Data															
			Assembly Manuals	2.3.1	G													

SUBMITTAL REGISTER

CONTRACT NO.

TITLE AND LOCATION

LRSO Hardware Software Development Facility

CONTRACTOR

ACTIVITY NO	TRANSMITTAL NO	SPEC SECT	DESCRIPTION ITEM SUBMITTED	PARAGRAPH	GOVT CLASSIFICATION	CONTRACTOR: SCHEDULE DATES			CONTRACTOR ACTION		APPROVING AUTHORITY				MAILED TO CONTR/ DATE RCD FRM APPR AUTH	REMARKS	
						SUBMIT	APPROVAL NEEDED BY	MATERIAL NEEDED BY	ACTION CODE	DATE OF ACTION	DATE FWD TO APPR AUTH/ DATE RCD FROM CONTR	DATE FWD TO OTHER REVIEWER	DATE RCD FROM OTH REVIEWER	ACTION CODE			DATE OF ACTION
		12 59 00	Maintenance Manuals	3.2	G												
			Cleaning	3.2	G												
			Maintenance Agreements	1.7													
			Installation	3.1	G												
		13 49 20.00 10	SD-02 Shop Drawings														
			Installation	3.2	G												
			Approved Drawings	1.3.1	G												
			SD-03 Product Data														
			RF Shielding System	3.2.1	G												
			Installation	3.2	G												
			Quality Control Plan	3.6	G												
			Qualifications	1.3.6	G												
			RF Shielded Doors	1.7.2.1	G												
			Penetrations	2.4.2	G												
			SD-10 Operation and Maintenance Data														
			Operating and Maintenance Manuals	1.7.3	G												
			Service Organization	2.2.1	G												
		21 13 13	SD-01 Preconstruction Submittals														
			Qualified Fire Protection Engineer (QFPE)	1.2.3	G												
			Sprinkler System Designer	1.4.2.1	G												
			Sprinkler System Installer	1.4.2.2	G												
			SD-02 Shop Drawings														
			Shop Drawing	1.2.1.1	G												

SUBMITTAL REGISTER

CONTRACT NO.

TITLE AND LOCATION

LRSO Hardware Software Development Facility

CONTRACTOR

ACTIVITY NO	TRANSMITTAL NO	SPEC SECT	DESCRIPTION ITEM SUBMITTED	PARAGRAPH	GOVT CLASSIFICATION	CONTRACTOR: SCHEDULE DATES			CONTRACTOR ACTION		APPROVING AUTHORITY				MAILED TO CONTR/ DATE RCD FRM APPR AUTH	REMARKS		
						SUBMIT	APPROVAL NEEDED BY	MATERIAL NEEDED BY	ACTION CODE	DATE OF ACTION	DATE FWD TO APPR AUTH/	DATE RCD FROM CONTR	DATE FWD TO OTHER REVIEWER	DATE RCD FROM OTH REVIEWER			ACTION CODE	DATE OF ACTION
		21 13 13	SD-03 Product Data															
			Pipe	2.2.1	G													
			Fittings	2.3.1.2	G													
			Valves	2.3.3	G													
			Alarm Valves	2.3.4	G													
			Relief Valves	2.8.4	G													
			Sprinklers	2.7	G													
			Pipe Hangers and Supports	2.3.2	G													
			Sprinkler Alarm Switch	2.4.1	G													
			Valve Supervisory (Tamper) Switch	2.4.2	G													
			Fire Department Connection	2.6	G													
			Backflow Prevention Assembly	2.5	G													
			Air Vent	2.8.5	G													
			Hose Valve	2.5.1	G													
			Seismic Bracing	2.3.2	G													
			Nameplates	2.1.2	G													
			Document Storage Cabinet	3.4.16	G													
			SD-05 Design Data															
			Seismic Bracing	2.3.2	G													
			Hydraulic Calculations	1.2.1.2	G													
			SD-06 Test Reports															
			Test Procedures	3.7.1	G													
			SD-07 Certificates															
			Verification of Compliant Installation	3.7.2.1	G													

SUBMITTAL REGISTER

CONTRACT NO.

TITLE AND LOCATION

LRSO Hardware Software Development Facility

CONTRACTOR

ACTIVITY NO	TRANSMITTAL NO	SPEC SECT	DESCRIPTION ITEM SUBMITTED	PARAGRAPH	GOVT CLASSIFICATION	CONTRACTOR: SCHEDULE DATES			CONTRACTOR ACTION		APPROVING AUTHORITY				MAILED TO CONTR/ DATE RCD FRM APPR AUTH	REMARKS		
						SUBMIT	APPROVAL NEEDED BY	MATERIAL NEEDED BY	ACTION CODE	DATE OF ACTION	DATE FWD TO APPR AUTH/	DATE RCD FROM CONTR	DATE FWD TO OTHER REVIEWER	DATE RCD FROM OTH REVIEWER			ACTION CODE	DATE OF ACTION
		21 13 13	Request for Government Final Test	3.7.2.2	G													
			SD-10 Operation and Maintenance Data															
			Operating and Maintenance (O&M) Instructions	3.9	G													
			Spare Parts	1.6	G													
			SD-11 Closeout Submittals															
			As-built drawings	3.9														
		21 22 00	SD-01 Preconstruction Submittals															
			Qualified Fire Protection Engineer	1.4.2	G													
			Manufacturer's Representative	1.4.4	G													
			SD-02 Shop Drawings															
			Clean Agent system piping layout	1.5.1	G													
			Field wiring diagrams	1.5.1	G													
			SD-03 Product Data															
			Storage cylinders	2.1.5	G													
			Discharge heads	3.7.2.1	G													
			Manifolds	2.1.5	G													
			Discharge nozzles	2.1.4	G													
			Pipe	2.1.1	G													
			Pipe hangers and supports	2.1.3	G													
			Control panel	2.2	G													
			Manual actuation stations	2.4	G													
			Pressure switches	2.1.5	G													
			Storage batteries	2.3.1	G													

SUBMITTAL REGISTER

CONTRACT NO.

TITLE AND LOCATION

LRSO Hardware Software Development Facility

CONTRACTOR

ACTIVITY NO	TRANSMITTAL NO	SPEC SECT	DESCRIPTION ITEM SUBMITTED	PARAGRAPH	GOVT CLASSIFICATION	CONTRACTOR: SCHEDULE DATES			CONTRACTOR ACTION		APPROVING AUTHORITY				MAILED TO CONTR/ DATE RCD FRM APPR AUTH	REMARKS		
						SUBMIT	APPROVAL NEEDED BY	MATERIAL NEEDED BY	ACTION CODE	DATE OF ACTION	DATE FWD TO APPR AUTH/	DATE RCD FROM CONTR	DATE FWD TO OTHER REVIEWER	DATE RCD FROM OTH REVIEWER			ACTION CODE	DATE OF ACTION
		21 22 00	Smoke detectors	2.5	G													
			Visual alarms	2.7.2	G													
			Battery charger	2.3.2	G													
			Fittings	2.1.2	G													
			Audible Alarm Bells	2.7.1	G													
			Warning Signs	2.8	G													
			SD-05 Design Data															
			Clean Agent discharge calculations	1.5.2	G													
			Battery capacity calculations	1.5.2	G													
			SD-07 Certificates															
			Record of Prior Installations	1.4.1	G													
			Clean Agent fire extinguishing system	1.4.3	G													
			SD-10 Operation and Maintenance Data															
			Clean Agent fire extinguishing system	1.4.3	G													
			SD-11 Closeout Submittals															
			Remote control station operating instructions	1.6.3	G													
			Record drawings	1.5.5	G													
		21 30 10	SD-01 Preconstruction Submittals															
			Qualified Fire Protection Engineer	1.6.1	G													
			Enclosure Manufacturer	1.6.4	G													
			Qualifications															

SUBMITTAL REGISTER

CONTRACT NO.

TITLE AND LOCATION

LRSO Hardware Software Development Facility

CONTRACTOR

ACTIVITY NO	TRANSMITTAL NO	SPEC SECT	DESCRIPTION ITEM SUBMITTED	PARAGRAPH	GOVT CLASSIFICATION	CONTRACTOR: SCHEDULE DATES			CONTRACTOR ACTION		APPROVING AUTHORITY				MAILED TO CONTR/ DATE RCD FRM APPR AUTH	REMARKS		
						SUBMIT	APPROVAL NEEDED BY	MATERIAL NEEDED BY	ACTION CODE	DATE OF ACTION	DATE FWD TO APPR AUTH/ DATE RCD FROM CONTR	DATE FWD TO OTHER REVIEWER	DATE RCD FROM OTH REVIEWER	ACTION CODE			DATE OF ACTION	
																		(a)
		21 30 10	SD-02 Shop Drawings															
			As-Built Drawings	3.11.3	G													
			Piping Layout	3.3.3	G													
			Pump Room	3.3.3	G													
			Enclosure Detail Drawings	3.3.1	G													
			SD-03 Product Data															
			Catalog Data	2.1	G													
			Spare Parts	1.5														
			Preliminary Tests	3.8.2														
			Field Tests	3.8	G													
			Manufacturer's Representative	1.6.7	G													
			Field Training	3.11.2	G													
			Army Final Acceptance Test	3.8.3														
			Fire Pump Enclosure - Structural Requirements	2.13.3	G													
			Fire Pump Enclosure - Architectural Requirements	2.13.4	G													
			Miscellaneous Building Accessories	2.13.4.3	G													
			Fire Pump Enclosure - Mechanical Requirements	2.13.5	G													
			Fire Pump Enclosure - Fire Protection Requirements	2.13.6	G													
			Fire Pump Enclosure - Electrical Requirements	2.13.7	G													
			SD-05 Design Data															

SUBMITTAL REGISTER

CONTRACT NO.

TITLE AND LOCATION

LRSO Hardware Software Development Facility

CONTRACTOR

ACTIVITY NO	TRANSMITTAL NO	SPEC SECT	DESCRIPTION ITEM SUBMITTED	PARAGRAPH	GOVT CLASSIFICATION	CONTRACTOR: SCHEDULE DATES			CONTRACTOR ACTION		APPROVING AUTHORITY				MAILED TO CONTR/ DATE RCD FRM APPR AUTH	REMARKS	
						SUBMIT	APPROVAL NEEDED BY	MATERIAL NEEDED BY	ACTION CODE	DATE OF ACTION	DATE FWD TO APPR AUTH/ DATE RCD FROM CONTR	DATE FWD TO OTHER REVIEWER	DATE RCD FROM OTH REVIEWER	ACTION CODE			DATE OF ACTION
		21 30 10	Fire Pump Installation Drawings	3.3.2	G												
			SD-06 Test Reports														
			Preliminary Tests	3.8.2													
			Army Final Acceptance Test	3.8.3													
			SD-07 Certificates														
			Qualified Fire Protection Engineer	1.6.1													
			Qualifications of Welders	1.6.2													
			Qualifications of Installer	1.6.3													
			Preliminary Test Certification	1.6.5													
			Final Test Certification	1.6.6													
			SD-10 Operation and Maintenance Data														
			Operating and Maintenance Instructions	3.11.2	G												
			Flow Meter	2.12													
		22 00 00	SD-02 Shop Drawings														
			Plumbing System	3.7.1	G												
			SD-03 Product Data														
			Thermostatic Mixing Valves	2.3.3	G												
			Fixtures	2.4													
			Flush Valve Urinals	2.4.1													
			WaterSense Label for Urinal	2.4.1	S												
			Flush Tank Water Closets	2.4.2													
			WaterSense Label for Flush Tank Water Closet	2.4.2	S												
			Countertop Lavatories	2.4.3													

SUBMITTAL REGISTER

CONTRACT NO.

TITLE AND LOCATION

LRSO Hardware Software Development Facility

CONTRACTOR

ACTIVITY NO	TRANSMITTAL NO	SPEC SECT	DESCRIPTION ITEM SUBMITTED	PARAGRAPH	GOVT CLASSIFICATION	CONTRACTOR: SCHEDULE DATES			CONTRACTOR ACTION		APPROVING AUTHORITY				MAILED TO CONTR/ DATE RCD FRM APPR AUTH	REMARKS	
						SUBMIT	APPROVAL NEEDED BY	MATERIAL NEEDED BY	ACTION CODE	DATE OF ACTION	DATE FWD TO APPR AUTH/ DATE RCD FROM CONTR	DATE FWD TO OTHER REVIEWER	DATE RCD FROM OTH REVIEWER	ACTION CODE			DATE OF ACTION
		22 00 00	Kitchen Sinks	2.4.4													
			Drinking-Water Coolers	2.4.5	G												
			Water Heaters	2.8	G												
			Welding	1.5.1													
			Plumbing System	3.7.1													
			Electrical Heat Tracing	2.12	G												
			SD-06 Test Reports														
			Tests, Flushing and Disinfection	3.7													
			SD-10 Operation and Maintenance Data														
			Plumbing System	3.7.1	G												
		23 05 93	SD-01 Preconstruction Submittals														
			TAB Firm	1.5.5.1	G												
			SD-02 Shop Drawings														
			TAB Schematic Drawings and Report Forms	1.3.2	G												
			SD-03 Product Data														
			TAB Procedures	1.5.4	G												
			Systems Readiness Check	1.3.2	G												
			TAB Verification	1.5.6.3	G												
			SD-06 Test Reports														
			Completed Pre-Final DALT Report	3.2.5	G												
			Certified Final DALT Report	3.2.8	G												
			TAB Report for Season 1	1.5.7.2	G												
			TAB Report for Season 2	1.5.7.2	G												

SUBMITTAL REGISTER

CONTRACT NO.

TITLE AND LOCATION

LRSO Hardware Software Development Facility

CONTRACTOR

ACTIVITY NO	TRANSMITTAL NO	SPEC SECT	DESCRIPTION ITEM SUBMITTED	PARAGRAPH	GOVT CLASSIFICATION	CONTRACTOR: SCHEDULE DATES			CONTRACTOR ACTION		APPROVING AUTHORITY				MAILED TO CONTR/ DATE RCD FRM APPR AUTH	REMARKS		
						SUBMIT	APPROVAL NEEDED BY	MATERIAL NEEDED BY	ACTION CODE	DATE OF ACTION	DATE FWD TO APPR AUTH/	DATE RCD FROM CONTR	DATE FWD TO OTHER REVIEWER	DATE RCD FROM OTH REVIEWER			ACTION CODE	DATE OF ACTION
		23 05 93	SD-07 Certificates															
			Independent TAB Agency and Personnel Qualifications	1.5.1	G													
			DALT and TAB Submittal and Work Schedule	1.6.2	G													
			TAB Pre-Field Engineering Report	1.6.2.1	G													
			Advanced Notice for Season 1 TAB Field Work	1.6.2	G													
			Prerequisite HVAC Work Check Out List For Season 1	1.6.2	G													
			Advanced Notice for Season 2 TAB Field Work	1.6.2	G													
			Prerequisite HVAC Work Check Out List For Season 2	1.6.2	G													
		23 09 00	SD-02 Shop Drawings															
			DDC Contractor Design Drawings	3.2	G													
			Draft As-Built Drawings	3.2	G													
			Final As-Built Drawings	3.2	G													
			SD-03 Product Data															
			Programming Software	1.8.3	G													
			Controller Application Programs	1.8.4	G													
			Configuration Software	1.8.1	G													
			Controller Configuration Settings	1.8.2	G													
			Manufacturer's Product Data	2.2	G													

SUBMITTAL REGISTER

CONTRACT NO.

TITLE AND LOCATION

LRSO Hardware Software Development Facility

CONTRACTOR

ACTIVITY NO	TRANSMITTAL NO	SPEC SECT	DESCRIPTION ITEM SUBMITTED	PARAGRAPH	GOVT CLASSIFICATION	CONTRACTOR: SCHEDULE DATES			CONTRACTOR ACTION		APPROVING AUTHORITY				MAILED TO CONTR/ DATE RCD FRM APPR AUTH	REMARKS		
						SUBMIT	APPROVAL NEEDED BY	MATERIAL NEEDED BY	ACTION CODE	DATE OF ACTION	DATE FWD TO APPR AUTH/	DATE RCD FROM CONTR	DATE FWD TO OTHER REVIEWER	DATE RCD FROM OTH REVIEWER			ACTION CODE	DATE OF ACTION
		23 09 00	Niagara Framework Supervisory Gateway Backups	1.8.5	G													
			Niagara Framework Engineering Tool	1.8.6	G													
			Maintenance Laptop	1.8.7	G													
			SD-06 Test Reports															
			Pre-Construction Quality Control (QC) Checklist	1.9.1	G													
			Post-Construction Quality Control (QC) Checklist	1.9.2	G													
			Start-Up Testing Report	3.4.2	G													
			PVT Procedures	3.5.1	G													
			PVT Report	3.5.3	G													
			SD-10 Operation and Maintenance Data															
			Operation and Maintenance (O&M) Instructions	3.6	G													
			Training Documentation	3.8.1	G													
			SD-11 Closeout Submittals															
			Enclosure Keys	2.5	G													
			Closeout Quality Control (QC) Checklist	1.9.3	G													
		23 23 00	SD-02 Shop Drawings															
			Refrigerant Piping System	2.2	G													
			SD-03 Product Data															
			Refrigerant Piping System	2.2														

SUBMITTAL REGISTER

CONTRACT NO.

TITLE AND LOCATION

LRSO Hardware Software Development Facility

CONTRACTOR

ACTIVITY NO	TRANSMITTAL NO	SPEC SECT	DESCRIPTION ITEM SUBMITTED	PARAGRAPH	GOVT CLASSIFICATION	CONTRACTOR: SCHEDULE DATES			CONTRACTOR ACTION		APPROVING AUTHORITY				MAILED TO CONTR/ DATE RCD FRM APPR AUTH	REMARKS	
						SUBMIT	APPROVAL NEEDED BY	MATERIAL NEEDED BY	ACTION CODE	DATE OF ACTION	DATE FWD TO APPR AUTH/	DATE RCD FROM CONTR	DATE FWD TO OTHER REVIEWER	DATE RCD FROM OTH REVIEWER			ACTION CODE
(a)	(b)	(c)	(d)	(e)	(f)	(g)	(h)	(i)	(j)	(k)	(l)	(m)	(n)	(o)	(p)	(q)	(r)
		23 23 00	Qualifications	1.3.1													
			Refrigerant Piping Tests	3.4													
			SD-06 Test Reports														
			Refrigerant Piping Tests	3.4													
			SD-07 Certificates														
			Service Organization	2.1													
			SD-10 Operation and Maintenance Data														
			Operation and Maintenance Manuals	3.3	G												
			Demonstrations	3.3	G												
		23 30 00	SD-02 Shop Drawings														
			Detail Drawings	1.4.4	G												
			SD-03 Product Data														
			Duct Access Doors	2.9.2	G												
			Manual Balancing Dampers	2.9.3	G												
			Automatic Smoke-Fire Dampers	2.9.4	G												
			Sound Attenuation Equipment	2.9.6	G												
			Diffusers	2.9.7.1													
			Registers and Grilles	2.9.7.2													
			In-Line Centrifugal Fans	2.10.1.1	G												
			Air Handling Units	2.11	G												
			Constant Volume, Single Duct Terminal Units	2.12.1.1	G												
			Variable Volume, Single Duct Terminal Units	2.12.1.2	G												

SUBMITTAL REGISTER

CONTRACT NO.

TITLE AND LOCATION

LRSO Hardware Software Development Facility

CONTRACTOR

ACTIVITY NO	TRANSMITTAL NO	SPEC SECT	DESCRIPTION ITEM SUBMITTED	PARAGRAPH	GOVT CLASSIFICATION	CONTRACTOR: SCHEDULE DATES			CONTRACTOR ACTION		APPROVING AUTHORITY				MAILED TO CONTR/ DATE RCD FRM APPR AUTH	REMARKS	
						SUBMIT	APPROVAL NEEDED BY	MATERIAL NEEDED BY	ACTION CODE	DATE OF ACTION	DATE FWD TO APPR AUTH/ DATE RCD FROM CONTR	DATE FWD TO OTHER REVIEWER	DATE RCD FROM OTH REVIEWER	ACTION CODE			DATE OF ACTION
		23 30 00	Reheat Units	2.12.1.3	G												
			Indoor Air Quality for Duct Sealants	2.9.1	S												
			SD-06 Test Reports														
			Performance Tests	3.12	G												
			Damper Acceptance Test	3.10	G												
			SD-07 Certificates														
			Ozone Depleting Substances Technician Certification	1.4.3													
			SD-08 Manufacturer's Instructions														
			Manufacturer's Installation Instructions	3.2													
			Operation and Maintenance Training	3.14.2													
			SD-10 Operation and Maintenance Data														
			Operation and Maintenance Manuals	3.14.1	G												
			Manual Balancing Dampers	2.9.3	G												
			Automatic Smoke-Fire Dampers	2.9.4	G												
			In-Line Centrifugal Fans	2.10.1.1	G												
			Air Handling Units	2.11	G												
			Constant Volume, Single Duct Terminal Units	2.12.1.1	G												
			Variable Volume, Single Duct Terminal Units	2.12.1.2	G												

SUBMITTAL REGISTER

CONTRACT NO.

TITLE AND LOCATION

LRSO Hardware Software Development Facility

CONTRACTOR

ACTIVITY NO	TRANSMITTAL NO	SPEC SECT	DESCRIPTION ITEM SUBMITTED	PARAGRAPH	GOVT CLASSIFICATION	CONTRACTOR: SCHEDULE DATES			CONTRACTOR ACTION		APPROVING AUTHORITY				MAILED TO CONTR/ DATE RCD FRM APPR AUTH	REMARKS		
						SUBMIT	APPROVAL NEEDED BY	MATERIAL NEEDED BY	ACTION CODE	DATE OF ACTION	DATE FWD TO APPR AUTH/	DATE RCD FROM CONTR	DATE FWD TO OTHER REVIEWER	DATE RCD FROM OTH REVIEWER			ACTION CODE	DATE OF ACTION
		23 30 00	Reheat Units	2.12.1.3	G													
			SD-11 Closeout Submittals															
			Indoor Air Quality During Construction	3.13	S													
		23 81 00	SD-03 Product Data															
			Spare Parts	3.7.1														
			Posted Instructions	3.4														
			Coil Corrosion Protection	2.4.1														
			System Performance Tests	3.6														
			Training	3.4	G													
			Inventory	1.4														
			Manufacturer's Standard Catalog Data	2.1														
			SD-06 Test Reports															
			Refrigerant Tests, Charging, and Start-Up	3.5	G													
			System Performance Tests	3.6	G													
			SD-07 Certificates															
			Service Organizations	3.7.2														
			SD-10 Operation and Maintenance Data															
			Operation and Maintenance Manuals	3.4	G													
			SD-11 Closeout Submittals															
			Ozone Depleting Substances	2.1.2.3	S													
		23 81 23	SD-03 Product Data															

SUBMITTAL REGISTER

CONTRACT NO.

TITLE AND LOCATION

LRSO Hardware Software Development Facility

CONTRACTOR

ACTIVITY NO	TRANSMITTAL NO	SPEC SECT	DESCRIPTION ITEM SUBMITTED	PARAGRAPH	GOVT CLASSIFICATION	CONTRACTOR: SCHEDULE DATES			CONTRACTOR ACTION		APPROVING AUTHORITY				MAILED TO CONTR/ DATE RCD FRM APPR AUTH	REMARKS	
						SUBMIT	APPROVAL NEEDED BY	MATERIAL NEEDED BY	ACTION CODE	DATE OF ACTION	DATE FWD TO APPR AUTH/ DATE RCD FROM CONTR	DATE FWD TO OTHER REVIEWER	DATE RCD FROM OTH REVIEWER	ACTION CODE			DATE OF ACTION
		23 81 23	Computer Room Air Conditioner	2.1	G												
			Space Temperature Control	2.5.2	G												
			System Drawings														
			Refrigerants	1.4	S												
			Leak Detection	2.2.1.3	G												
			SD-06 Test Reports														
			Manufacturer's Factory Test Plans	2.7.1	G												
			Factory Test Reports	2.7.4	G												
			Field Test Schedule	3.3.2	G												
			Manufacturer's Field Test Plans	3.3.1	G												
			Field Test Reports	3.3.6	G												
			SD-07 Certificates														
			Credentials of the Manufacturer's Field Test Representative	3.3.3	G												
			Ozone Depleting Substances Technician Certification	1.5.1													
			Certified List Of Qualified Permanent Service Organizations	1.6.3													
			SD-08 Manufacturer's Instructions														
			Installation Manual for Each Type of CRAC	3.1.2													
			SD-10 Operation and Maintenance Data														
			Computer Room Air Conditioner Operation and Maintenance Data	3.1.3	G												

SUBMITTAL REGISTER

CONTRACT NO.

TITLE AND LOCATION

LRSO Hardware Software Development Facility

CONTRACTOR

ACTIVITY NO	TRANSMITTAL NO	SPEC SECT	DESCRIPTION ITEM SUBMITTED	PARAGRAPH	GOVT CLASSIFICATION	CONTRACTOR: SCHEDULE DATES			CONTRACTOR ACTION		APPROVING AUTHORITY				MAILED TO CONTR/ DATE RCD FRM APPR AUTH	REMARKS		
						SUBMIT	APPROVAL NEEDED BY	MATERIAL NEEDED BY	ACTION CODE	DATE OF ACTION	DATE FWD TO APPR AUTH/ DATE RCD FROM CONTR	DATE FWD TO OTHER REVIEWER	DATE RCD FROM OTH REVIEWER	ACTION CODE			DATE OF ACTION	
																		(g)
		23 81 23	SD-11 Closeout Submittals															
			Indoor Air Quality During Construction	3.2	S													
		23 83 00.00 20	SD-02 Shop Drawings															
			Heater Installation Drawing	3.1														
			SD-03 Product Data															
			Electric Unit Heaters	2.1														
			SD-10 Operation and Maintenance Data															
			Electric Unit Heaters	2.1														
		25 05 11.21	SD-01 Preconstruction Submittals															
			Device Account Lock Exception Request	3.3.2	G													
			Multiple Ethernet Connection Device Request	3.2.5.2	G													
			Contractor Computer Cybersecurity Compliance Statements	1.10.1.6	G													
			Contractor Temporary Network Cybersecurity Compliance Statements	1.10.6	G													
			Protection of Information At Rest Proposal	3.7.4	G													
			Proposed STIG and SRG Applicability Report	1.8.1	G													
			SD-02 Shop Drawings															

SUBMITTAL REGISTER

CONTRACT NO.

TITLE AND LOCATION

LRSO Hardware Software Development Facility

CONTRACTOR

ACTIVITY NO	TRANSMITTAL NO	SPEC SECT	DESCRIPTION ITEM SUBMITTED	PARAGRAPH	GOVT CLASSIFICATION	CONTRACTOR: SCHEDULE DATES			CONTRACTOR ACTION		APPROVING AUTHORITY				MAILED TO CONTR/ DATE RCD FRM APPR AUTH	REMARKS	
						SUBMIT	APPROVAL NEEDED BY	MATERIAL NEEDED BY	ACTION CODE	DATE OF ACTION	DATE FWD TO APPR AUTH/ DATE RCD FROM CONTR	DATE FWD TO OTHER REVIEWER	DATE RCD FROM OTH REVIEWER	ACTION CODE			DATE OF ACTION
		25 05 11.21	Network Communication Report	1.8.2	G												
			Cybersecurity Riser Diagram	1.8.5	G												
			SD-03 Product Data														
			Control System Cybersecurity Documentation	1.8.7	G												
			SD-06 Test Reports														
			Control System Cybersecurity Testing Procedures	3.14.1	G												
			Control System Cybersecurity Testing Report	3.14.3	G												
			SD-07 Certificates														
			Software Licenses	1.9	G												
			SD-11 Closeout Submittals														
			Confidential Password Report	3.4.4.4	G												
			Enclosure Keys	3.3.7	G												
			Software and Configuration Backups	1.8.4	G												
			Device Audit Record Upload Software	3.5.3.1	G												
			System Maintenance Tool Software	3.9	G												
			Control System Scanning Tools	3.11.1	G												
			STIG, SRG and Vendor Guide Compliance Result Report	1.8.6	G												
			Control System Inventory Report	1.8.3	G												
			Integrity Verification Software	3.13.1	G												

SUBMITTAL REGISTER

CONTRACT NO.

TITLE AND LOCATION

LRSO Hardware Software Development Facility

CONTRACTOR

ACTIVITY NO	TRANSMITTAL NO	SPEC SECT	DESCRIPTION ITEM SUBMITTED	PARAGRAPH	GOVT CLASSIFICATION	CONTRACTOR: SCHEDULE DATES			CONTRACTOR ACTION		APPROVING AUTHORITY				MAILED TO CONTR/ DATE RCD FRM APPR AUTH	REMARKS		
						SUBMIT	APPROVAL NEEDED BY	MATERIAL NEEDED BY	ACTION CODE	DATE OF ACTION	DATE FWD TO APPR AUTH/	DATE RCD FROM CONTR	DATE FWD TO OTHER REVIEWER	DATE RCD FROM OTH REVIEWER			ACTION CODE	DATE OF ACTION
		25 05 11.25	SD-01 Preconstruction Submittals															
			Device Account Lock Exception Request	3.3.2	G													
			Multiple Ethernet Connection Device Request	3.2.4.2	G													
			Contractor Computer Cybersecurity Compliance Statements	1.10.1.6	G													
			Contractor Temporary Network Cybersecurity Compliance Statements	1.10.6	G													
			Protection of Information At Rest Proposal	3.7.4	G													
			Proposed STIG and SRG Applicability Report	1.8.1	G													
			SD-02 Shop Drawings															
			Network Communication Report	1.8.2	G													
			Cybersecurity Riser Diagram	1.8.5	G													
			SD-03 Product Data															
			Control System Cybersecurity Documentation	1.8.7	G													
			SD-06 Test Reports															
			Control System Cybersecurity Testing Procedures	3.13.1	G													
			Control System Cybersecurity Testing Report	3.13.3	G													

SUBMITTAL REGISTER

CONTRACT NO.

TITLE AND LOCATION

LRSO Hardware Software Development Facility

CONTRACTOR

ACTIVITY NO	TRANSMITTAL NO	SPEC SECT	DESCRIPTION ITEM SUBMITTED	PARAGRAPH	GOVERNOR CLASSIFICATION	CONTRACTOR: SCHEDULE DATES			CONTRACTOR ACTION		APPROVING AUTHORITY				MAILED TO CONTR/ DATE RCD FRM APPR AUTH	REMARKS		
						SUBMIT	APPROVAL NEEDED BY	MATERIAL NEEDED BY	ACTION CODE	DATE OF ACTION	DATE FWD TO APPR AUTH/	DATE RCD FROM CONTR	DATE FWD TO OTHER REVIEWER	DATE RCD FROM OTH REVIEWER			ACTION CODE	DATE OF ACTION
		25 05 11.25	SD-07 Certificates															
			Software Licenses	1.9	G													
			SD-11 Closeout Submittals															
			Confidential Password Report	3.4.5.5	G													
			Enclosure Keys	3.3.7	G													
			Software and Configuration Backups	1.8.4	G													
			Auditing Front End Software	3.5.3	G													
			Device Audit Record Upload	3.5.4.2	G													
			Software															
			System Maintenance Tool	3.9	G													
			Software															
			Control System Scanning Tools	3.11.2	G													
			STIG, SRG and Vendor Guide	1.8.6	G													
			Compliance Result Report															
			Control System Inventory Report	1.8.3	G													
			Integrity Verification Software	3.12.2	G													
		25 05 11.26	SD-01 Preconstruction Submittals															
			Device Account Lock Exception Request	3.3.2	G													
			Multiple Ethernet Connection	3.2.4.2	G													
			Device Request															
			Contractor Computer	1.10.1.6	G													
			Cybersecurity Compliance Statements															

SUBMITTAL REGISTER

CONTRACT NO.

TITLE AND LOCATION

LRSO Hardware Software Development Facility

CONTRACTOR

ACTIVITY NO	TRANSMITTAL NO	SPEC SECT	DESCRIPTION ITEM SUBMITTED	PARAGRAPH	GOVT CLASSIFICATION	CONTRACTOR: SCHEDULE DATES			CONTRACTOR ACTION		APPROVING AUTHORITY				MAILED TO CONTR/ DATE RCD FRM APPR AUTH	REMARKS	
						SUBMIT	APPROVAL NEEDED BY	MATERIAL NEEDED BY	ACTION CODE	DATE OF ACTION	DATE FWD TO APPR AUTH/ DATE RCD FROM CONTR	DATE FWD TO OTHER REVIEWER	DATE RCD FROM OTH REVIEWER	ACTION CODE			DATE OF ACTION
		25 05 11.26	Contractor Temporary Network Cybersecurity Compliance Statements	1.10.6	G												
			Protection of Information At Rest Proposal	3.7.4	G												
			Proposed STIG and SRG Applicability Report	1.8.1	G												
			SD-02 Shop Drawings														
			Network Communication Report	1.8.2	G												
			Cybersecurity Riser Diagram	1.8.5	G												
			SD-03 Product Data														
			Control System Cybersecurity Documentation	1.8.7	G												
			SD-06 Test Reports														
			Control System Cybersecurity Testing Procedures	3.14.1	G												
			Control System Cybersecurity Testing Report	3.14.3	G												
			SD-07 Certificates														
			Software Licenses	1.9	G												
			SD-11 Closeout Submittals														
			Confidential Password Report	3.4.4.5	G												
			Enclosure Keys	3.3.7	G												
			Software and Configuration Backups	1.8.4	G												
			Auditing Front End Software	3.5.3	G												

SUBMITTAL REGISTER

CONTRACT NO.

TITLE AND LOCATION

LRSO Hardware Software Development Facility

CONTRACTOR

ACTIVITY NO	TRANSMITTAL NO	SPEC SECT	DESCRIPTION ITEM SUBMITTED	PARAGRAPH	GOVT CLASSIFICATION	CONTRACTOR: SCHEDULE DATES			CONTRACTOR ACTION		APPROVING AUTHORITY					REMARKS		
						SUBMIT	APPROVAL NEEDED BY	MATERIAL NEEDED BY	ACTION CODE	DATE OF ACTION	DATE FWD TO APPR AUTH/ FROM CONTR	DATE FWD TO OTHER REVIEWER	DATE RCD FROM OTH REVIEWER	ACTION CODE	DATE OF ACTION		MAILED TO CONTR/ DATE RCD FRM APPR AUTH	
																		(g)
		25 05 11.26	Device Audit Record Upload Software	3.5.4.2	G													
			System Maintenance Tool Software	3.9	G													
			Control System Scanning Tools STIG, SRG and Vendor Guide	3.11.2	G													
			Compliance Result Report	1.8.6	G													
			Control System Inventory Report	1.8.3	G													
			Integrity Verification Software	3.13.2	G													
		25 05 11.28	SD-01 Preconstruction Submittals															
			Device Account Lock Exception Request	3.3.2	G													
			Multiple Ethernet Connection Device Request	3.2.4.2	G													
			Contractor Computer Cybersecurity Compliance Statements	1.10.1.6	G													
			Contractor Temporary Network Cybersecurity Compliance Statements	1.10.6	G													
			Protection of Information At Rest Proposal	3.7.4	G													
			Proposed STIG and SRG Applicability Report	1.8.1	G													
			SD-02 Shop Drawings															
			Network Communication Report	1.8.2	G													

SUBMITTAL REGISTER

CONTRACT NO.

TITLE AND LOCATION

LRSO Hardware Software Development Facility

CONTRACTOR

ACTIVITY NO	TRANSMITTAL NO	SPEC SECT	DESCRIPTION ITEM SUBMITTED	PARAGRAPH	GOVT CLASSIFICATION	CONTRACTOR: SCHEDULE DATES			CONTRACTOR ACTION		APPROVING AUTHORITY					REMARKS			
						SUBMIT	APPROVAL NEEDED BY	MATERIAL NEEDED BY	ACTION CODE	DATE OF ACTION	DATE FWD TO APPR AUTH/	DATE RCD FROM CONTR	DATE FWD TO OTHER REVIEWER	DATE RCD FROM OTH REVIEWER	ACTION CODE		DATE OF ACTION	MAILED TO CONTR/	DATE RCD FRM APPR AUTH
		25 05 11.28	Cybersecurity Riser Diagram	1.8.5	G														
			SD-03 Product Data																
			Control System Cybersecurity Documentation	1.8.7	G														
			SD-06 Test Reports																
			Control System Cybersecurity Testing Procedures	3.14.1	G														
			Control System Cybersecurity Testing Report	3.14.3	G														
			SD-07 Certificates																
			Software Licenses	1.9	G														
			SD-11 Closeout Submittals																
			Confidential Password Report	3.4.4.5	G														
			Enclosure Keys	3.3.7	G														
			Software and Configuration Backups	1.8.4	G														
			Auditing Front End Software	3.5.3	G														
			Device Audit Record Upload Software	3.5.4.2	G														
			System Maintenance Tool Software	3.9	G														
			Control System Scanning Tools	3.11.2	G														
			STIG, SRG and Vendor Guide Compliance Result Report	1.8.6	G														
			Control System Inventory Report	1.8.3	G														
			Integrity Verification Software	3.13.2	G														

SUBMITTAL REGISTER

CONTRACT NO.

TITLE AND LOCATION

LRSO Hardware Software Development Facility

CONTRACTOR

ACTIVITY NO	TRANSMITTAL NO	SPEC SECT	DESCRIPTION ITEM SUBMITTED	PARAGRAPH	GOVT CLASSIFICATION	CONTRACTOR: SCHEDULE DATES			CONTRACTOR ACTION		APPROVING AUTHORITY				MAILED TO CONTR/ DATE RCD FRM APPR AUTH	REMARKS		
						SUBMIT	APPROVAL NEEDED BY	MATERIAL NEEDED BY	ACTION CODE	DATE OF ACTION	DATE FWD TO APPR AUTH/	DATE RCD FROM CONTR	DATE FWD TO OTHER REVIEWER	DATE RCD FROM OTH REVIEWER			ACTION CODE	DATE OF ACTION
		25 08 10	SD-06 Test Reports															
			PVT Plan	3.1.1	G													
			PVT Phase I Report	3.1.2.1	G													
			PVT Phase II Report	3.1.2.2	G													
			SD-07 Certificates															
			Test Instrumentation Calibration Certificates	1.4	G													
		25 10 10	SD-02 Shop Drawings															
			UMCS Contractor Design Drawings	3.2.1	G													
			Draft As-Built Drawings	3.2.2	G													
			Final As-Built Drawings	3.2.2	G													
			SD-03 Product Data															
			Product Data Sheets	2.1.5	G													
			Computer Software	2.4	G													
			SD-06 Test Reports															
			Pre-Construction QC Checklist	1.7	G													
			Post-Construction QC Checklist	1.7	G													
			Existing Conditions Report	3.1	G													
			Start-Up and Start-Up Testing Report	3.6	G													
			PVT Phase I Procedures	3.7.1	G													
			PVT Phase I Report	3.7.2	G													
			PVT Phase II Report	3.7.3	G													
			SD-10 Operation and Maintenance Data															

SUBMITTAL REGISTER

CONTRACT NO.

TITLE AND LOCATION
 LRSO Hardware Software Development Facility

CONTRACTOR

ACTIVITY NO	TRANSMITTAL NO	SPEC SECT	DESCRIPTION ITEM SUBMITTED	PARAGRAPH	GOVERNOR CLASSIFICATION	CONTRACTOR: SCHEDULE DATES			CONTRACTOR ACTION		APPROVING AUTHORITY					REMARKS		
						SUBMIT	APPROVAL NEEDED BY	MATERIAL NEEDED BY	ACTION CODE	DATE OF ACTION	DATE FWD TO APPR AUTH/ FROM CONTR	DATE FWD TO OTHER REVIEWER	DATE RCD FROM OTH REVIEWER	ACTION CODE	DATE OF ACTION		MAILED TO CONTR/ DATE RCD FRM APPR AUTH	
																		(g)
		25 10 10	Operation and Maintenance (O&M) Instructions	1.8	G													
			Basic Training Documentation	3.9.1	G													
			SD-11 Closeout Submittals															
			Closeout QC Checklist	1.7	G													
		26 08 00	SD-06 Test Reports															
			Acceptance Tests and Inspections	3.1	G													
			SD-07 Certificates															
			Qualifications	1.4.1	G													
			Acceptance Test and Inspections Procedure	1.4.3	G													
		26 20 00	SD-02 Shop Drawings															
			Panelboards	2.12	G													
			Transformers	2.15	G													
			Cable Trays	2.3	G													
			Wireways	2.27	G													
			Marking Strips	3.1.10.1	G													
			SD-03 Product Data															
			Receptacles	2.11	G													
			Circuit Breakers	2.12.3	G													
			Switches	2.9	G													
			Transformers	2.15	G													
			Enclosed Circuit Breakers	2.13	G													
			Motor Controllers	2.17	G													
			Manual Motor Starters	2.18	G													

SUBMITTAL REGISTER

CONTRACT NO.

TITLE AND LOCATION

LRSO Hardware Software Development Facility

CONTRACTOR

ACTIVITY NO	TRANSMITTAL NO	SPEC SECT	DESCRIPTION ITEM SUBMITTED	PARAGRAPH	GOVT CLASSIFICATION	CONTRACTOR: SCHEDULE DATES			CONTRACTOR ACTION		APPROVING AUTHORITY					REMARKS		
						SUBMIT	APPROVAL NEEDED BY	MATERIAL NEEDED BY	ACTION CODE	DATE OF ACTION	DATE FWD TO APPR AUTH/ FROM CONTR	DATE FWD TO OTHER REVIEWER	DATE RCD FROM OTH REVIEWER	ACTION CODE	DATE OF ACTION		MAILED TO CONTR/ DATE RCD FRM APPR AUTH	
																		(g)
		26 20 00	Metering	2.28	G													
			Secondary Bonding Busbar	2.21.3	G													
			Surge Protective Devices	2.29	G													
			Cable Trays	2.3	G													
			Conductors	2.6.1	G													
			Cable Tray Design	2.3	G													
			SD-06 Test Reports															
			600-volt Wiring Test	3.5.2	G													
			Grounding System Test	3.5.5	G													
			Transformer Tests	3.5.3	G													
			Ground-fault Receptacle Test	3.5.4	G													
			SD-07 Certificates															
			Fuses	2.10	G													
			SD-09 Manufacturer's Field Reports															
			Transformer Factory Tests	2.31.1														
			SD-10 Operation and Maintenance Data															
			Electrical Systems	1.6.1	G													
			Metering	2.28	G													
		26 27 13.10 30	SD-03 Product Data															
			Power Meters	2.1	G													
			Current	2.1.3	G													
			Potential Transformer	2.1.2	G													
			Protocol Modules	1.6.1	G													
			Data Recorder	1.6.2	G													

SUBMITTAL REGISTER

CONTRACT NO.

TITLE AND LOCATION

LRSO Hardware Software Development Facility

CONTRACTOR

ACTIVITY NO	TRANSMITTAL NO	SPEC SECT	DESCRIPTION ITEM SUBMITTED	PARAGRAPH	GOVT CLASSIFICATION	CONTRACTOR: SCHEDULE DATES			CONTRACTOR ACTION		APPROVING AUTHORITY				MAILED TO CONTR/ DATE RCD FRM APPR AUTH	REMARKS	
						SUBMIT	APPROVAL NEEDED BY	MATERIAL NEEDED BY	ACTION CODE	DATE OF ACTION	DATE FWD TO APPR AUTH/ DATE RCD FROM CONTR	DATE FWD TO OTHER REVIEWER	DATE RCD FROM OTH REVIEWER	ACTION CODE			DATE OF ACTION
		26 27 13.10 30	Modem	1.6.2	G												
			SD-06 Test Reports														
			Acceptance Checks and Tests	3.3.1	G												
			SD-10 Operation and Maintenance Data														
			Power Meters	2.1	G												
			Protocol Modules	1.6.1	G												
			Data Recorder	1.6.2	G												
			Modem	1.6.2	G												
			SD-11 Closeout Submittals														
			System Function Verification	3.3.2	G												
		26 29 23	SD-02 Shop Drawings														
			Schematic Diagrams	1.5.1	G												
			Interconnecting Diagrams	1.5.2	G												
			Installation Drawings	1.5.3	G												
			As-Built Drawings	1.5.3	G												
			SD-03 Product Data														
			Adjustable Speed Drives	2.1	G												
			Wires and Cables	2.3													
			Equipment Schedule	1.5.4													
			SD-06 Test Reports														
			ASD Test	3.3.1													
			Performance Verification Tests	3.3.2													
			Endurance Test	3.3.3													
			SD-07 Certificates														

SUBMITTAL REGISTER

CONTRACT NO.

TITLE AND LOCATION
 LRSO Hardware Software Development Facility

CONTRACTOR

ACTIVITY NO	TRANSMITTAL NO	SPEC SECT	DESCRIPTION ITEM SUBMITTED	PARAGRAPH	GOVT CLASSIFICATION	CONTRACTOR: SCHEDULE DATES			CONTRACTOR ACTION		APPROVING AUTHORITY				MAILED TO CONTR/ DATE RCD FRM APPR AUTH	REMARKS		
						SUBMIT	APPROVAL NEEDED BY	MATERIAL NEEDED BY	ACTION CODE	DATE OF ACTION	DATE FWD TO APPR AUTH/	DATE RCD FROM CONTR	DATE FWD TO OTHER REVIEWER	DATE RCD FROM OTH REVIEWER			ACTION CODE	DATE OF ACTION
		26 29 23	Testing Agency's Field Supervisor	3.3.1	G													
			SD-08 Manufacturer's Instructions Installation instructions	1.5.5														
			SD-09 Manufacturer's Field Reports															
			ASD Test Plan	2.5.1	G													
			Standard Products	1.5.6														
			SD-10 Operation and Maintenance Data															
			Adjustable Speed Drives	2.1														
		26 32 15.00	SD-02 Shop Drawings															
			Engine-Generator Set and Auxiliary Equipment	2.1.1	G													
			Auxiliary Systems	1.4.9	G													
			Detailed Drawings	1.4.8	G													
			Acceptance	3.17	G													
			SD-03 Product Data															
			Harmonic Requirements	2.1.8	G													
			Engine-Generator Set	2.1.1	G													
			Efficiencies															
			Emissions	2.12	G													
			filters	2.7.2	G													
			special tools	2.14	G													
			Engine-Generator Parameter	2.1.1														
			Schedule															

SUBMITTAL REGISTER

CONTRACT NO.

TITLE AND LOCATION

LRSO Hardware Software Development Facility

CONTRACTOR

ACTIVITY NO	TRANSMITTAL NO	SPEC SECT	DESCRIPTION ITEM SUBMITTED	PARAGRAPH	GOVT CLASSIFICATION	CONTRACTOR: SCHEDULE DATES			CONTRACTOR ACTION		APPROVING AUTHORITY				MAILED TO CONTR/ DATE RCD FRM APPR AUTH	REMARKS		
						SUBMIT	APPROVAL NEEDED BY	MATERIAL NEEDED BY	ACTION CODE	DATE OF ACTION	DATE FWD TO APPR AUTH/	DATE RCD FROM CONTR	DATE FWD TO OTHER REVIEWER	DATE RCD FROM OTH REVIEWER			ACTION CODE	DATE OF ACTION
		26 32 15.00	Heat Exchanger	2.8.2														
			Generator	2.15														
			Manufacturer's Catalog	2.5														
			Spare Parts	1.7.2														
			Onsite Training	3.12														
			Vibration-Isolation	2.1.7														
			Posted Data and Instructions	3.16	G													
			Instructions	3.6.7.1	G													
			Experience	1.4.6														
			Field Engineer	1.4.7														
			General Installation	3.2														
			Exciter	2.16														
			SD-05 Design Data															
			Performance Criteria	2.15														
			Sound Limitations	2.9	G													
			Day Tank	2.6.1														
			Power Factor	3.6.1.2														
			Heat Exchanger	2.8.2														
			Time-Delay on Alarms	2.19.5														
			Cooling System	2.8														
			Vibration Isolation	2.1.7														
			Battery Charger	2.13.3.2														
			Capacity Calculations for Engine-Generator Set	2.1.1	G													
			Brake Mean Effective Pressure (BMEP) Calculations	2.1.1	G													

SUBMITTAL REGISTER

CONTRACT NO.

TITLE AND LOCATION

LRSO Hardware Software Development Facility

CONTRACTOR

ACTIVITY NO	TRANSMITTAL NO	SPEC SECT	DESCRIPTION ITEM SUBMITTED	PARAGRAPH	GOVT CLASSIFICATION	CONTRACTOR: SCHEDULE DATES			CONTRACTOR ACTION		APPROVING AUTHORITY				MAILED TO CONTR/ DATE RCD FRM APPR AUTH	REMARKS	
						SUBMIT	APPROVAL NEEDED BY	MATERIAL NEEDED BY	ACTION CODE	DATE OF ACTION	DATE FWD TO APPR AUTH/ DATE RCD FROM CONTR	DATE FWD TO OTHER REVIEWER	DATE RCD FROM OTH REVIEWER	ACTION CODE			DATE OF ACTION
		26 32 15.00	Torsional Vibration Stress Analysis Computations	2.1.1	G												
			Capacity Calculations for Batteries	2.1.1	G												
			SD-06 Test Reports														
			Performance Tests	3.6.9													
			Factory Inspection and Tests	2.27													
			Factory Tests	2.27.2													
			Onsite Inspection and Tests	3.6	G												
			Acceptance Checks and Tests	3.9.2	G												
			Functional Acceptance Tests	3.10.2	G												
			Maintenance Procedures	3.12	G												
			Operation and Maintenance Manuals	3.12	G												
			Inspections	3.6.3	G												
			Functional Acceptance Test Procedure	3.9.6	G												
			SD-07 Certificates														
			Cooling System	2.8													
			Vibration Isolation	2.1.7													
			Prototype Test	2.27.2													
			Reliability and Durability	2.1.5													
			Fuel System Certification	1.4.12	G												
			Start-Up Engineer	3.8	G												
			Instructor's Qualification Resume	3.11.1	G												
			Engine Emission Limits	2.1.2.1	G												

SUBMITTAL REGISTER

CONTRACT NO.

TITLE AND LOCATION

LRSO Hardware Software Development Facility

CONTRACTOR

ACTIVITY NO	TRANSMITTAL NO	SPEC SECT	DESCRIPTION ITEM SUBMITTED	PARAGRAPH	GOVT CLASSIFICATION	CONTRACTOR: SCHEDULE DATES			CONTRACTOR ACTION		APPROVING AUTHORITY				MAILED TO CONTR/ DATE RCD FRM APPR AUTH	REMARKS		
						SUBMIT	APPROVAL NEEDED BY	MATERIAL NEEDED BY	ACTION CODE	DATE OF ACTION	DATE FWD TO APPR AUTH/	DATE RCD FROM CONTR	DATE FWD TO OTHER REVIEWER	DATE RCD FROM OTH REVIEWER			ACTION CODE	DATE OF ACTION
		26 32 15.00	Sound Limitations	2.9														
			Site Visit	3.1														
			Current Balance	2.15.1														
			Materials and Equipment	2.4														
			Factory Inspection and Tests	2.27														
			Engine Tests	3.6.4	G													
			Generator Tests	3.6.5	G													
			Assembled Engine-Generator Set Tests	3.6.6	G													
			SD-10 Operation and Maintenance Data															
			Preliminary Assembled Operation and Maintenance Manuals	3.9.5	G													
			Posted Data and Instructions	3.16	G													
			Training Plan	3.11.2	G													
		26 33 53	SD-02 Shop Drawings															
			UPS Drawings	1.5.1	G													
			UPS Installation	1.5.2	G													
			SD-03 Product Data															
			UPS Module	2.5	G													
			Technical Requirements UPS System	2.4														
			Spare Parts	1.4.2	G													
			SD-06 Test Reports															
			Work Plan	1.5.3	G													
			Factory Test Plan	1.5.4	G													

SUBMITTAL REGISTER

CONTRACT NO.

TITLE AND LOCATION
 LRSO Hardware Software Development Facility

CONTRACTOR

ACTIVITY NO	TRANSMITTAL NO	SPEC SECT	DESCRIPTION ITEM SUBMITTED	PARAGRAPH	GOVT CLASSIFICATION	CONTRACTOR: SCHEDULE DATES			CONTRACTOR ACTION		APPROVING AUTHORITY				MAILED TO CONTR/ DATE RCD FRM APPR AUTH	REMARKS		
						SUBMIT	APPROVAL NEEDED BY	MATERIAL NEEDED BY	ACTION CODE	DATE OF ACTION	DATE FWD TO APPR AUTH/	DATE RCD FROM CONTR	DATE FWD TO OTHER REVIEWER	DATE RCD FROM OTH REVIEWER			ACTION CODE	DATE OF ACTION
		26 33 53	Factory Test Report	1.5.5	G													
			SD-09 Manufacturer's Field Reports															
			Initial Inspection and Tests	3.2.2	G													
			Performance Tests	3.2.3	G													
			Performance Test Plan	1.5.6	G													
			Performance Test Report	1.5.7	G													
			SD-10 Operation and Maintenance Data															
			UPS Operation and Maintenance	1.4.1	G													
			SD-11 Closeout Submittals Installation	3.1														
		26 36 23	SD-02 Shop Drawings															
			Automatic Transfer Switch Drawings	1.5.2	G													
			SD-03 Product Data															
			Automatic Transfer Switches	2.1	G													
			By-Pass/Isolation Switch (BP/IS)	2.3	G													
			SD-06 Test Reports															
			Acceptance Checks and Tests	3.3.1	G													
			Functional Acceptance Tests	3.3.2	G													
			Factory Testing	2.5	G													
			Factory Test Reports	2.5.2	G													
			SD-07 Certificates															
			Proof of Listing	1.5.1	G													

SUBMITTAL REGISTER

CONTRACT NO.

TITLE AND LOCATION

LRSO Hardware Software Development Facility

CONTRACTOR

ACTIVITY NO	TRANSMITTAL NO	SPEC SECT	DESCRIPTION ITEM SUBMITTED	PARAGRAPH	GOVT CLASSIFICATION	CONTRACTOR: SCHEDULE DATES			CONTRACTOR ACTION		APPROVING AUTHORITY				MAILED TO CONTR/ DATE RCD FRM APPR AUTH	REMARKS		
						SUBMIT	APPROVAL NEEDED BY	MATERIAL NEEDED BY	ACTION CODE	DATE OF ACTION	DATE FWD TO APPR AUTH/	DATE RCD FROM CONTR	DATE FWD TO OTHER REVIEWER	DATE RCD FROM OTH REVIEWER			ACTION CODE	DATE OF ACTION
		26 36 23	SD-10 Operation and Maintenance Data															
			Operation and Maintenance Manual	1.4	G													
		26 41 00	SD-06 Test Reports															
			Lightning Protection and Grounding System Test Plan	1.5.2	G													
			Grounding Systems Testing	3.5.2	G													
			SD-07 Certificates															
			Component UL Listed and Labeled	1.5.1	G													
			Lightning Protection System Inspection Certificate	1.5.3	G													
			Roof Manufacturer's Warranty	3.1.1.1	G													
		26 51 00	SD-02 Shop Drawings															
			Luminaire Drawings	1.5.1	G													
			Occupancy/Vacancy Sensor Coverage Layout	1.5.9	G													
			Lighting Control System One-Line Diagram	1.7.2	G													
			Sequence of Operation for Lighting Control System	2.5.1	G													
			SD-03 Product Data															
			Luminaires	2.2	G													
			Light Sources	2.3	G													
			LED Drivers	2.4	G													

SUBMITTAL REGISTER

CONTRACT NO.

TITLE AND LOCATION

LRSO Hardware Software Development Facility

CONTRACTOR

ACTIVITY NO	TRANSMITTAL NO	SPEC SECT	DESCRIPTION ITEM SUBMITTED	PARAGRAPH	GOVT CLASSIFICATION	CONTRACTOR: SCHEDULE DATES			CONTRACTOR ACTION		APPROVING AUTHORITY				MAILED TO CONTR/ DATE RCD FRM APPR AUTH	REMARKS		
						SUBMIT	APPROVAL NEEDED BY	MATERIAL NEEDED BY	ACTION CODE	DATE OF ACTION	DATE FWD TO APPR AUTH/	DATE RCD FROM CONTR	DATE FWD TO OTHER REVIEWER	DATE RCD FROM OTH REVIEWER			ACTION CODE	DATE OF ACTION
		26 51 00	Luminaire Warranty	1.6.1	G													
			Lighting Controls Warranty	1.6.2	G													
			Lighting Contactor	2.5.1.2	G													
			Switches	2.5.2.1	G													
			Digital Switch Timers	2.5.2.2	G													
			Wall Box Dimmers	2.5.2.3	G													
			Occupancy/Vacancy Sensors	2.5.2.4	G													
			Power Packs	2.5.2.4.3	G													
			Exit Signs	2.6.1	G													
			Emergency Drivers	2.6.2	G													
			SD-05 Design Data															
			Luminaire Design Data	1.5.2	G													
			Photometric Plan	1.5.8	G													
			SD-06 Test Reports															
			ANSI/IES LM-79 Test Report	1.5.3	G													
			ANSI/IES LM-80 Test Report	1.5.4	G													
			ANSI/IES TM-21 Test Report	1.5.5	G													
			ANSI/IES TM-30 Test Report	1.5.6	G													
			Occupancy/Vacancy Sensor	3.2.1.1	G													
			Verification Test															
			Photosensor Verification Test	3.2.1.1														
			SD-07 Certificates															
			LED Driver and Dimming Switch	1.5.7	G													
			Compatibility Certificate															
			SD-10 Operation and Maintenance															
			Data															

SUBMITTAL REGISTER

CONTRACT NO.

TITLE AND LOCATION

LRSO Hardware Software Development Facility

CONTRACTOR

ACTIVITY NO	TRANSMITTAL NO	SPEC SECT	DESCRIPTION ITEM SUBMITTED	PARAGRAPH	GOVT CLASSIFICATION	CONTRACTOR: SCHEDULE DATES			CONTRACTOR ACTION		APPROVING AUTHORITY				MAILED TO CONTR/ DATE RCD FRM APPR AUTH	REMARKS	
						SUBMIT	APPROVAL NEEDED BY	MATERIAL NEEDED BY	ACTION CODE	DATE OF ACTION	DATE FWD TO APPR AUTH/ DATE RCD FROM CONTR	DATE FWD TO OTHER REVIEWER	DATE RCD FROM OTH REVIEWER	ACTION CODE			DATE OF ACTION
		26 51 00	Lighting System	1.7.1	G												
			Lighting Control System	1.7.2	G												
			Maintenance Staff Training Plan	3.3.2.1	G												
			End-User Training Plan	3.3.2.2	G												
		26 56 00	SD-02 Shop Drawings														
			Luminaire Drawings	1.5.1.1	G												
			Pole Drawings	1.5.1.2	G												
			Control System One-Line Diagram	1.8.2	G												
			Sequence of Operation for Exterior Lighting Control System	2.5.1	G												
			SD-03 Product Data														
			Luminaires	2.2	G												
			Light Sources	2.3	G												
			LED Drivers	2.4	G												
			Luminaire Warranty	1.7.1	G												
			Lighting Controls Warranty	1.7.2	G												
			Pole Warranty	1.7.3	G												
			Photosensors	2.5.2.2	G												
			Time Clock	2.5.2.1	G												
			Lighting Contactor	2.5.2.3	G												
			Poles	2.6	G												
			Brackets	2.6.2													
			SD-05 Design Data														
			Luminaire Design Data	1.5.2	G												
			Photometric Plan	1.5.6	G												

SUBMITTAL REGISTER

CONTRACT NO.

TITLE AND LOCATION

LRSO Hardware Software Development Facility

CONTRACTOR

ACTIVITY NO	TRANSMITTAL NO	SPEC SECT	DESCRIPTION ITEM SUBMITTED	PARAGRAPH	GOVT CLASSIFICATION	CONTRACTOR: SCHEDULE DATES			CONTRACTOR ACTION		APPROVING AUTHORITY				MAILED TO CONTR/ DATE RCD FRM APPR AUTH	REMARKS		
						SUBMIT	APPROVAL NEEDED BY	MATERIAL NEEDED BY	ACTION CODE	DATE OF ACTION	DATE FWD TO APPR AUTH/	DATE RCD FROM CONTR	DATE FWD TO OTHER REVIEWER	DATE RCD FROM OTH REVIEWER			ACTION CODE	DATE OF ACTION
		26 56 00	SD-06 Test Reports															
			ANSI/IES LM-79 Test Report	1.5.3	G													
			ANSI/IES LM-80 Test Report	1.5.4	G													
			ANSI/IES TM-21 Test Report	1.5.5	G													
			SD-08 Manufacturer's Instructions															
			Poles	2.6														
			SD-10 Operation and Maintenance Data															
			Lighting System	1.8.1	G													
			Exterior Lighting Control System	1.8.2	G													
			Maintenance Staff Training Plan	3.3.1.1	G													
			End-User Training Plan	3.3.1.2	G													
		27 10 00	SD-02 Shop Drawings															
			Telecommunications Drawings	1.6.1.1	G													
			Telecommunications Space Drawings	1.6.1.2	G													
			SD-03 Product Data															
			Telecommunications Cabling	2.3	G													
			Patch Panels	2.4.4	G													
			Telecommunications Outlet/Connector Assemblies	2.5	G													
			Equipment Support Frame	2.4.2	G													
			SD-06 Test Reports															
			Telecommunications Cabling Testing	3.5.1	G													
			SD-07 Certificates															

SUBMITTAL REGISTER

CONTRACT NO.

TITLE AND LOCATION

LRSO Hardware Software Development Facility

CONTRACTOR

ACTIVITY NO	TRANSMITTAL NO	SPEC SECT	DESCRIPTION ITEM SUBMITTED	PARAGRAPH	GOVT CLASSIFICATION	CONTRACTOR: SCHEDULE DATES			CONTRACTOR ACTION		APPROVING AUTHORITY				MAILED TO CONTR/ DATE RCD FRM APPR AUTH	REMARKS		
						SUBMIT	APPROVAL NEEDED BY	MATERIAL NEEDED BY	ACTION CODE	DATE OF ACTION	DATE FWD TO APPR AUTH/	DATE RCD FROM CONTR	DATE FWD TO OTHER REVIEWER	DATE RCD FROM OTH REVIEWER			ACTION CODE	DATE OF ACTION
		27 10 00	Telecommunications Contractor	1.6.2.1	G													
			Key Personnel	1.6.2.2	G													
			Manufacturer Qualifications	1.6.2.3	G													
			Test Plan	1.6.3	G													
			SD-09 Manufacturer's Field Reports															
			Factory Reel Tests	2.10.1	G													
			SD-10 Operation and Maintenance Data															
			Telecommunications Cabling and Pathway System	1.10.1	G													
			SD-11 Closeout Submittals															
			Record Documentation	1.10.2	G													
		28 31 76	SD-01 Preconstruction Submittals															
			Qualified Fire Protection Engineer (QFPE)	1.3.2	G													
			Fire alarm system designer	1.8.2.1	G													
			Supervisor	1.8.2.2	G													
			Technician	1.8.2.3	G													
			Installer	1.8.2.4	G													
			Test Technician	1.8.2.5	G													
			Fire Alarm System Site-Specific Software Acknowledgement	1.7	G													
			SD-02 Shop Drawings															
			Nameplates	1.8.1.3	G													
			Instructions	2.2.4	G													

SUBMITTAL REGISTER

CONTRACT NO.

TITLE AND LOCATION

LRSO Hardware Software Development Facility

CONTRACTOR

ACTIVITY NO	TRANSMITTAL NO	SPEC SECT	DESCRIPTION ITEM SUBMITTED	PARAGRAPH	GOVT CLASSIFICATION	CONTRACTOR: SCHEDULE DATES			CONTRACTOR ACTION		APPROVING AUTHORITY				MAILED TO CONTR/ DATE RCD FRM APPR AUTH	REMARKS		
						SUBMIT	APPROVAL NEEDED BY	MATERIAL NEEDED BY	ACTION CODE	DATE OF ACTION	DATE FWD TO APPR AUTH/	DATE RCD FROM CONTR	DATE FWD TO OTHER REVIEWER	DATE RCD FROM OTH REVIEWER			ACTION CODE	DATE OF ACTION
		28 31 76	Wiring Diagrams	1.8.1.4	G													
			System Layout	1.8.1.5	G													
			Notification Appliances	1.8.1.6	G													
			Initiating devices	1.8.1.7	G													
			Amplifiers	1.8.1.8	G													
			Battery Power	1.8.1.9	G													
			Voltage Drop Calculations	1.8.1.10	G													
			SD-03 Product Data															
			Fire Alarm and Mass Notification Control Unit (FMCU)	2.3	G													
			Local Operating Console (LOC)	1.4.3	G													
			Amplifiers	1.8.1.8	G													
			Tone Generators	2.5	G													
			Digitalized voice generators	2.5	G													
			Manual Stations	2.6	G													
			Smoke Detectors	2.7	G													
			Duct Smoke Detectors	2.7.2	G													
			Air sampling smoke detectors	3.2.6	G													
			Addressable Interface Devices	2.9	G													
			Addressable Control Modules	2.10	G													
			Notification Appliances	1.8.1.6	G													
			Textual Display Signs	2.11.3	G													
			Batteries	2.13.1	G													
			Battery Chargers	2.13.2	G													
			Supplemental Notification	2.13.1.1	G													
			Appliance Circuit Panels															

SUBMITTAL REGISTER

CONTRACT NO.

TITLE AND LOCATION

LRSO Hardware Software Development Facility

CONTRACTOR

ACTIVITY NO	TRANSMITTAL NO	SPEC SECT	DESCRIPTION ITEM SUBMITTED	PARAGRAPH	GOVT CLASSIFICATION	CONTRACTOR: SCHEDULE DATES			CONTRACTOR ACTION		APPROVING AUTHORITY					REMARKS		
						SUBMIT	APPROVAL NEEDED BY	MATERIAL NEEDED BY	ACTION CODE	DATE OF ACTION	DATE FWD TO APPR AUTH/ FROM CONTR	DATE FWD TO OTHER REVIEWER	DATE RCD FROM OTH REVIEWER	ACTION CODE	DATE OF ACTION		MAILED TO CONTR/ DATE RCD FRM APPR AUTH	
																		(g)
		28 31 76	Auxiliary Power Supply Panels	2.13.1.1	G													
			Surge Protective Devices	2.14	G													
			Alarm Wiring	2.14	G													
			Back Boxes and Conduit	3.3.4	G													
			Ceiling Bridges	3.2.8	G													
			Terminal Cabinets	3.3.2	G													
			Radio Transmitter and Interface Panels	2.17.1	G													
			Mass Notification Transceiver	2.16.1	G													
			Environmental Enclosures or Guards	2.19	G													
			Document Storage Cabinet	3.9.3	G													
			SD-05 Design Data															
			Air Sampling Smoke Detection System Calculations	1.8.1.12	G													
			SD-06 Test Reports															
			Test Procedures	3.5.1	G													
			SD-07 Certificates															
			Verification of Compliant Installation	3.5.2.1	G													
			Request for Government Final Test	3.5.2.2	G													
			SD-10 Operation and Maintenance Data															
			Operation and Maintenance (O&M) Instructions	3.7	G													

SUBMITTAL REGISTER

CONTRACT NO.

TITLE AND LOCATION

LRSO Hardware Software Development Facility

CONTRACTOR

ACTIVITY NO	TRANSMITTAL NO	SPEC SECT	DESCRIPTION ITEM SUBMITTED	PARAGRAPH	GOVT CLASSIFICATION	CONTRACTOR: SCHEDULE DATES			CONTRACTOR ACTION		APPROVING AUTHORITY					REMARKS			
						SUBMIT	APPROVAL NEEDED BY	MATERIAL NEEDED BY	ACTION CODE	DATE OF ACTION	DATE FWD TO APPR AUTH/	DATE RCD FROM CONTR	DATE FWD TO OTHER REVIEWER	DATE RCD FROM OTH REVIEWER	ACTION CODE		DATE OF ACTION	MAILED TO CONTR/	DATE RCD FRM APPR AUTH
		28 31 76	Instruction of Government Employees	3.8	G														
			SD-11 Closeout Submittals																
			As-Built Drawings	1.8.1.14															
			Spare Parts	1.10.1															
		31 00 00	SD-01 Preconstruction Submittals																
			Excavation and Trenching Plan	3.1.3	G														
			Borrow Plan	3.2	G														
			Dewatering Work Plan	3.1.2.2	G														
			Disposition of Surplus Materials	3.9	G														
			Preconstruction Meeting	1.6.4	G														
			SD-03 Product Data																
			Flowable Fill Mix Design	2.2	G														
			SD-06 Test Reports																
			Material Test Report	3.10	G														
			Borrow Site Testing	3.2.2	G														
			Pipe Inspection Report	3.6.1.7	G														
			Geotechnical Evaluation Report	1.6.1	G														
		31 11 00	SD-01 Preconstruction Submittals																
			Herbicide Application Plan	3.1.1															
			SD-03 Product Data																
			Tree Wound Paint	2.1.1															
			Herbicides	1.3.2	G														
			SD-07 Certificates																
			Qualifications	1.3.2	G														
			SD-11 Closeout Submittals																

SUBMITTAL REGISTER

CONTRACT NO.

TITLE AND LOCATION

LRSO Hardware Software Development Facility

CONTRACTOR

ACTIVITY NO	TRANSMITTAL NO	SPEC SECT	DESCRIPTION ITEM SUBMITTED	PARAGRAPH	GOVT CLASSIFICATION	CONTRACTOR: SCHEDULE DATES			CONTRACTOR ACTION		APPROVING AUTHORITY				MAILED TO CONTR/ DATE RCD FRM APPR AUTH	REMARKS	
						SUBMIT	APPROVAL NEEDED BY	MATERIAL NEEDED BY	ACTION CODE	DATE OF ACTION	DATE FWD TO APPR AUTH/ DATE RCD FROM CONTR	DATE FWD TO OTHER REVIEWER	DATE RCD FROM OTH REVIEWER	ACTION CODE			DATE OF ACTION
		31 11 00	Pest Management Report	3.5.1													
		32 01 19.61	SD-03 Product Data														
			Sealants	2.1													
			Manufacturer's Recommendations	3.5.2													
			SD-04 Samples														
			Sealants	2.1													
			Blocking Media/Backup Materials	2.3.1													
			Backer Rod	3.3.3.1													
			Bond Breaking Tapes	2.3.2													
			SD-06 Test Reports														
			Sealants	2.1													
			SD-07 Certificates														
			Equipment List	3.1													
			SD-08 Manufacturer's Instructions														
			Sealants	2.1													
		32 05 33	SD-01 Preconstruction Submittals														
			Integrated Pest Management Plan	2.3	G												
			SD-03 Product Data														
			Fertilizer	2.1	G												
			SD-07 Certificates														
			Maintenance Inspection Report	3.4.1													
			SD-10 Operation and Maintenance Data														
			Maintenance	1.6													

SUBMITTAL REGISTER

CONTRACT NO.

TITLE AND LOCATION

LRSO Hardware Software Development Facility

CONTRACTOR

ACTIVITY NO	TRANSMITTAL NO	SPEC SECT	DESCRIPTION ITEM SUBMITTED	PARAGRAPH	GOVT CLASSIFICATION	CONTRACTOR: SCHEDULE DATES			CONTRACTOR ACTION		APPROVING AUTHORITY				MAILED TO CONTR/ DATE RCD FRM APPR AUTH	REMARKS	
						SUBMIT	APPROVAL NEEDED BY	MATERIAL NEEDED BY	ACTION CODE	DATE OF ACTION	DATE FWD TO APPR AUTH/ DATE RCD FROM CONTR	DATE FWD TO OTHER REVIEWER	DATE RCD FROM OTH REVIEWER	ACTION CODE			DATE OF ACTION
		32 11 23	SD-03 Product Data Plant, Equipment, and Tools	2.4	G												
			SD-06 Test Reports Initial Tests	2.3.1	G												
			In-Place Tests	3.12.1	G												
		32 12 13	SD-03 Product Data Local/Regional Materials	2.2.1													
			SD-06 Test Reports Sampling and Testing	3.7													
		32 12 16.16	SD-02 Shop Drawings Placement Plan	2.1	G												
			SD-03 Product Data Diamond Grinding Plan	2.1.5	G												
			Mix Design	2.5	G												
			Contractor Quality Control	3.1	G												
			SD-04 Samples Aggregates	2.2													
			Asphalt Cement Binder	2.3													
			Warm-mix Additive	2.5.1													
			SD-06 Test Reports Aggregates	2.2	G												
			QC Monitoring	3.1.3.9													
			SD-07 Certificates Asphalt Cement Binder	2.3	G												
			Laboratory Accreditation and Validation	1.3.11													

SUBMITTAL REGISTER

CONTRACT NO.

TITLE AND LOCATION

LRSO Hardware Software Development Facility

CONTRACTOR

ACTIVITY NO	TRANSMITTAL NO	SPEC SECT	DESCRIPTION ITEM SUBMITTED	PARAGRAPH	GOVT CLASSIFICATION	CONTRACTOR: SCHEDULE DATES			CONTRACTOR ACTION		APPROVING AUTHORITY				MAILED TO CONTR/ DATE RCD FRM APPR AUTH	REMARKS		
						SUBMIT	APPROVAL NEEDED BY	MATERIAL NEEDED BY	ACTION CODE	DATE OF ACTION	DATE FWD TO APPR AUTH/ DATE RCD FROM CONTR	DATE FWD TO OTHER REVIEWER	DATE RCD FROM OTH REVIEWER	ACTION CODE			DATE OF ACTION	
																		(g)
		32 12 16.16	Warm-mix Additive	2.5.1														
		32 13 13.06	SD-03 Product Data															
			Curing Materials	2.1.6														
			Reinforcement	2.1.5.3														
			Epoxy Resin	2.1.9														
			Epoxy Resin	2.1.9														
			Cementitious Materials	2.1.1	G													
			Cementitious Materials	2.1.1	G													
			Albedo	2.2.1.5														
			Dowel Bars	2.1.5.1														
			Expansion Joint Filler	2.1.10.1														
			SD-04 Samples															
			Test Section	1.5.2	G													
			SD-05 Design Data															
			Mix Design Report	2.2.2	G													
			SD-06 Test Reports															
			Concrete Slump Tests	3.7.2														
			Concrete Uniformity	2.3.1														
			Flexural Strength	3.7.3														
			Air Content	3.7.4														
			SD-07 Certificates															
			Batch Tickets	1.3.3														
			NRMCA Certificate Of Conformance	1.3.1														
			SD-08 Manufacturer's Instructions															
			Diamond Grinding Plan	3.7.5.4														

SUBMITTAL REGISTER

CONTRACT NO.

TITLE AND LOCATION

LRSO Hardware Software Development Facility

CONTRACTOR

ACTIVITY NO	TRANSMITTAL NO	SPEC SECT	DESCRIPTION ITEM SUBMITTED	PARAGRAPH	GOVT CLASSIFICATION	CONTRACTOR: SCHEDULE DATES			CONTRACTOR ACTION		APPROVING AUTHORITY				MAILED TO CONTR/ DATE RCD FRM APPR AUTH	REMARKS		
						SUBMIT	APPROVAL NEEDED BY	MATERIAL NEEDED BY	ACTION CODE	DATE OF ACTION	DATE FWD TO APPR AUTH/	DATE RCD FROM CONTR	DATE FWD TO OTHER REVIEWER	DATE RCD FROM OTH REVIEWER			ACTION CODE	DATE OF ACTION
		32 13 73.19	SD-03 Product Data															
			Equipment	2.1														
			Manufacturer's Instructions	3.1.1														
			SD-04 Samples															
			Compression Seals	2.2	G													
			SD-06 Test Reports															
			Test Requirements	2.1.3	G													
		32 16 19	SD-03 Product Data															
			Concrete	2.1														
			Biodegradable Form Release Agent	2.6.4														
			Biodegradable Form Release Agent	3.2														
			SD-06 Test Reports															
			Field Quality Control	3.8														
		32 17 23	SD-03 Product Data															
			Surface Preparation Equipment List	2.1.1.2	G													
			Application Equipment List	2.1.2	G													
			Exterior Surface Preparation	3.2														
			Safety Data Sheets	1.3.1	G													
			Waterborne Paint	2.2.1	G													
			Solventborne Paint	2.2.2	G													
			SD-06 Test Reports															
			Waterborne Paint	2.2.1	G													
			Solventborne Paint	2.2.2	G													

SUBMITTAL REGISTER

CONTRACT NO.

TITLE AND LOCATION

LRSO Hardware Software Development Facility

CONTRACTOR

ACTIVITY NO	TRANSMITTAL NO	SPEC SECT	DESCRIPTION ITEM SUBMITTED	PARAGRAPH	GOVT CLASSIFICATION	CONTRACTOR: SCHEDULE DATES			CONTRACTOR ACTION		APPROVING AUTHORITY				MAILED TO CONTR/ DATE RCD FRM APPR AUTH	REMARKS		
						SUBMIT	APPROVAL NEEDED BY	MATERIAL NEEDED BY	ACTION CODE	DATE OF ACTION	DATE FWD TO APPR AUTH/	DATE RCD FROM CONTR	DATE FWD TO OTHER REVIEWER	DATE RCD FROM OTH REVIEWER			ACTION CODE	DATE OF ACTION
		32 17 23	SD-07 Certificates															
			Qualifications	1.3.2	G													
			Waterborne Paint	2.2.1														
			Solventborne Paint	2.2.2														
			Volatile Organic Compound	1.3.1	G													
			SD-08 Manufacturer's Instructions															
			Waterborne Paint	2.2.1	G													
			Solventborne Paint	2.2.2	G													
		32 92 19	SD-03 Product Data															
			Wood Cellulose Fiber Mulch	2.5.3														
			Fertilizer	2.4														
			SD-06 Test Reports															
			Topsoil Composition Tests	2.2.3														
			SD-07 Certificates															
			Seed	2.1														
			SD-08 Manufacturer's Instructions															
			Erosion Control Materials	2.7														
		33 01 50.31	SD-02 Shop Drawings															
			Leak Detection System	2.3	G													
			Electronic Monitoring/Alarm Panel	2.4														
			SD-03 Product Data															
			Leak Detection System	2.3	G													
			Electronic Monitoring/Alarm Panel	2.4														
			SD-06 Test Reports															

SUBMITTAL REGISTER

CONTRACT NO.

TITLE AND LOCATION

LRSO Hardware Software Development Facility

CONTRACTOR

ACTIVITY NO	TRANSMITTAL NO	SPEC SECT	DESCRIPTION ITEM SUBMITTED	PARAGRAPH	GOVT CLASSIFICATION	CONTRACTOR: SCHEDULE DATES			CONTRACTOR ACTION		APPROVING AUTHORITY				MAILED TO CONTR/ DATE RCD FRM APPR AUTH	REMARKS	
						SUBMIT	APPROVAL NEEDED BY	MATERIAL NEEDED BY	ACTION CODE	DATE OF ACTION	DATE FWD TO APPR AUTH/ DATE RCD FROM CONTR	DATE FWD TO OTHER REVIEWER	DATE RCD FROM OTH REVIEWER	ACTION CODE			DATE OF ACTION
		33 01 50.31	Leak Detection System Test	3.2.1													
			SD-07 Certificates														
			Demonstrations	3.3													
			SD-08 Manufacturer's Instructions														
			Leak Detection System	2.3													
			SD-10 Operation and Maintenance Data														
			Leak Detection System	2.3	G												
			Electronic Monitoring/Alarm Panel	2.4	G												
		33 11 00	SD-01 Preconstruction Submittals														
			Connections	3.1.1	G												
			SD-03 Product Data														
			Pipe, Fittings, Joints and Couplings	2.1.1	G												
			Valves	2.1.2	G												
			Valve Boxes	2.1.2.4	G												
			Fire Hydrants	2.1.4.1	G												
			Pipe Restraint	2.2.1	G												
			Tapping Sleeves	2.2.2	G												
			Backflow Preventer	1.4.2.1.1	G												
			Precast Concrete Thrust Blocks	2.2.1.2	G												
			Disinfection Procedures	3.2.4	G												
			SD-06 Test Reports														
			Backflow Preventer Tests	3.3.1.4	G												
			Bacteriological Samples	3.3.1.3	G												

SUBMITTAL REGISTER

CONTRACT NO.

TITLE AND LOCATION

LRSO Hardware Software Development Facility

CONTRACTOR

ACTIVITY NO	TRANSMITTAL NO	SPEC SECT	DESCRIPTION ITEM SUBMITTED	PARAGRAPH	GOVT CLASSIFICATION	CONTRACTOR: SCHEDULE DATES			CONTRACTOR ACTION		APPROVING AUTHORITY				MAILED TO CONTR/ DATE RCD FRM APPR AUTH	REMARKS		
						SUBMIT	APPROVAL NEEDED BY	MATERIAL NEEDED BY	ACTION CODE	DATE OF ACTION	DATE FWD TO APPR AUTH/ DATE RCD FROM CONTR	DATE FWD TO OTHER REVIEWER	DATE RCD FROM OTH REVIEWER	ACTION CODE			DATE OF ACTION	
																		(a)
		33 11 00	Leakage Test	3.3.1.2														
			Hydrostatic Test	3.3.1.1														
			SD-07 Certificates															
			Pipe, Fittings, Joints and Couplings	2.1.1														
			Lining for Fittings	2.1.1.1.2														
			Valves	2.1.2														
			Fire Hydrants	2.1.4.1														
			Backflow Prevention Training Certificate	1.4.2.1.1.1														
			Turbine Type Meters	2.1.5.1														
			Fire Service Type Meters	2.1.5.2														
			SD-08 Manufacturer's Instructions															
			PVC Piping	2.1.1.1.1.1														
			PVC Piping For Service Lines	2.1.1.1.2														
		33 30 00	SD-01 Preconstruction Submittals															
			Contractor's License	1.3.1	G													
			SD-02 Shop Drawings															
			Installation Drawings	3.1.1	G													
			SD-03 Product Data															
			Precast Concrete Manholes	2.2.6														
			Frames, Covers, and Gratings	2.2.9														
			Gravity Pipe	2.2.1														
			Pressure Pipe	2.2.2														
			SD-06 Test Reports															
			Hydrostatic Sewer Test	3.3.1.1	G													

SUBMITTAL REGISTER

CONTRACT NO.

TITLE AND LOCATION

LRSO Hardware Software Development Facility

CONTRACTOR

ACTIVITY NO	TRANSMITTAL NO	SPEC SECT	DESCRIPTION ITEM SUBMITTED	PARAGRAPH	GOVT CLASSIFICATION	CONTRACTOR: SCHEDULE DATES			CONTRACTOR ACTION		APPROVING AUTHORITY				MAILED TO CONTR/ DATE RCD FRM APPR AUTH	REMARKS		
						SUBMIT	APPROVAL NEEDED BY	MATERIAL NEEDED BY	ACTION CODE	DATE OF ACTION	DATE FWD TO APPR AUTH/	DATE RCD FROM CONTR	DATE FWD TO OTHER REVIEWER	DATE RCD FROM OTH REVIEWER			ACTION CODE	DATE OF ACTION
		33 30 00	Infiltration Tests And Exfiltration Tests	3.3.1.2.1	G													
			Low-Pressure Air Tests	3.3.1.2.2	G													
			Tests For Pressure Lines	3.3.1.3	G													
			SD-07 Certificates															
			Portland Cement	2.2.4														
			Pre-Installation Inspection Request	3.3.2.1	G													
			Post-Installation Inspection	3.3.2.2	G													
		33 40 00	SD-06 Test Reports															
			Leakage Test	3.7.1.1	G													
			SD-07 Certificates															
			Hydrostatic Test on Watertight Joints	2.4.1	G													
			SD-08 Manufacturer's Instructions															
			Placing Pipe	3.3	G													
			SD-11 Closeout Submittals															
			Post-Installation Inspection Report	3.7.2.1.3	G													
		33 71 02	SD-02 Shop Drawings															
			Precast Underground Structures	1.4.1	G													
			SD-03 Product Data															
			Precast Concrete Structures	2.10.2.1	G													
			Sealing Material	2.10.2.4														
			Pulling-In Irons	3.4.3														
			Manhole Frames and Covers	2.10.3	G													

SUBMITTAL REGISTER

CONTRACT NO.

TITLE AND LOCATION
 LRSO Hardware Software Development Facility

CONTRACTOR

ACTIVITY NO	TRANSMITTAL NO	SPEC SECT	DESCRIPTION ITEM SUBMITTED	PARAGRAPH	GOVT CLASSIFICATION	CONTRACTOR: SCHEDULE DATES			CONTRACTOR ACTION		APPROVING AUTHORITY				MAILED TO CONTR/ DATE RCD FRM APPR AUTH	REMARKS		
						SUBMIT	APPROVAL NEEDED BY	MATERIAL NEEDED BY	ACTION CODE	DATE OF ACTION	DATE FWD TO APPR AUTH/	DATE RCD FROM CONTR	DATE FWD TO OTHER REVIEWER	DATE RCD FROM OTH REVIEWER			ACTION CODE	DATE OF ACTION
		33 71 02	Handhole Frames and Covers	2.10.4	G													
			Composite/Fiberglass Handholes	2.10.6	G													
			Cable Supports	2.11	G													
			SD-06 Test Reports															
			Field Acceptance Checks and Tests	3.15.1	G													
			SD-07 Certificates															
			Cable Installer Qualifications	1.4.2	G													
		33 82 00	SD-02 Shop Drawings															
			Telecommunications Outside Plant	1.6.1.1	G													
			Telecommunications Entrance Facility Drawings	1.6.1.2	G													
			SD-03 Product Data															
			Wire and Cable	2.7														
			Cable Splices, and Connectors	2.4	G													
			Closures	2.3	G													
			SD-06 Test Reports															
			Pre-installation Tests	3.4.1	G													
			Acceptance Tests	3.4.2	G													
			Outside Plant Test Plan	1.6.3	G													
			SD-07 Certificates															
			Telecommunications Contractor	1.6.2.1	G													
			Key Personnel	1.6.2.2	G													
			Manufacturer's Qualifications	1.6.2.3	G													
			SD-08 Manufacturer's Instructions															

SUBMITTAL REGISTER

CONTRACT NO.

TITLE AND LOCATION

LRSO Hardware Software Development Facility

CONTRACTOR

ACTIVITY NO	TRANSMITTAL NO	SPEC SECT	DESCRIPTION ITEM SUBMITTED	PARAGRAPH	GOVT CLASSIFICATION	CONTRACTOR: SCHEDULE DATES			CONTRACTOR ACTION		APPROVING AUTHORITY					REMARKS		
						SUBMIT	APPROVAL NEEDED BY	MATERIAL NEEDED BY	ACTION CODE	DATE OF ACTION	DATE FWD TO APPR AUTH/ DATE RCD FROM CONTR	DATE FWD TO OTHER REVIEWER	DATE RCD FROM OTH REVIEWER	ACTION CODE	DATE OF ACTION		MAILED TO CONTR/ DATE RCD FRM APPR AUTH	
																		(g)
		33 82 00	Cable Tensions	3.1.8.1	G													
			Fiber Optic Splices	3.1.9.1	G													
			SD-09 Manufacturer's Field Reports															
			Factory Reel Test Data	2.14.1	G													
			SD-10 Operation and Maintenance Data															
			Telecommunications Outside Plant (OSP)	1.6.1.1														
			SD-11 Closeout Submittals Record Documentation	1.8.1	G													

SECTION 03 30 00

CAST-IN-PLACE CONCRETE

02/19, CHG 7: 02/24

PART 1 GENERAL

1.1 REFERENCES

The publications listed below form a part of this specification to the extent referenced. The publications are referred to within the text by the basic designation only.

AMERICAN CONCRETE INSTITUTE (ACI)

ACI 117	(2010; Errata 2011) Specifications for Tolerances for Concrete Construction and Materials and Commentary
ACI 121R	(2008) Guide for Concrete Construction Quality Systems in Conformance with ISO 9001
ACI 301	(2016) Specifications for Structural Concrete
ACI 302.1R	(2015) Guide for Concrete Floor and Slab Construction
ACI 304.2R	(2017) Guide to Placing Concrete by Pumping Methods
ACI 304R	(2000; R 2009) Guide for Measuring, Mixing, Transporting, and Placing Concrete
ACI 305.1	(2014) Specification for Hot Weather Concreting
ACI 305R	(2020) Guide to Hot Weather Concreting
ACI 306.1	(1990; R 2002) Standard Specification for Cold Weather Concreting
ACI 306R	(2016) Guide to Cold Weather Concreting
ACI 308.1	(2023) Specification for Curing Concrete
ACI CT	(2018) ACI Concrete Terminology
ACI MNL-2	(2019; Abstract: 11th Edition) ACI Manual of Concrete Inspection
ACI 318	(2019; R 2022) Building Code Requirements for Structural Concrete (ACI 318-19) and Commentary (ACI 318R-19)
ACI SP-15	(2011) Field Reference Manual: Standard Specifications for Structural Concrete ACI

301-05 with Selected ACI References

AMERICAN HARDBOARD ASSOCIATION (AHA)

AHA A135.4 (1995; R 2004) Basic Hardboard

AMERICAN WELDING SOCIETY (AWS)

AWS D1.4/D1.4M (2018) Structural Welding Code -
Reinforcing Steel

ASTM INTERNATIONAL (ASTM)

ASTM A36/A36M (2019) Standard Specification for Carbon
Structural Steel

ASTM A53/A53M (2024) Standard Specification for Pipe,
Steel, Black and Hot-Dipped, Zinc-Coated,
Welded and Seamless

ASTM A615/A615M (2022) Standard Specification for Deformed
and Plain Carbon-Steel Bars for Concrete
Reinforcement

ASTM A706/A706M (2022a) Standard Specification for
Low-Alloy Steel Deformed and Plain Bars
for Concrete Reinforcement

ASTM A934/A934M (2022) Standard Specification for
Epoxy-Coated Prefabricated Steel
Reinforcing Bars

ASTM A996/A996M (2016) Standard Specification for
Rail-Steel and Axle-Steel Deformed Bars
for Concrete Reinforcement

ASTM A1064/A1064M (2022) Standard Specification for
Carbon-Steel Wire and Welded Wire
Reinforcement, Plain and Deformed, for
Concrete

ASTM C31/C31M (2023) Standard Practice for Making and
Curing Concrete Test Specimens in the Field

ASTM C33/C33M (2024) Standard Specification for Concrete
Aggregates

ASTM C39/C39M (2023) Standard Test Method for
Compressive Strength of Cylindrical
Concrete Specimens

ASTM C42/C42M (2020) Standard Test Method for Obtaining
and Testing Drilled Cores and Sawed Beams
of Concrete

ASTM C78/C78M (2022) Standard Test Method for Flexural
Strength of Concrete (Using Simple Beam
with Third-Point Loading)

ASTM C94/C94M	(2023) Standard Specification for Ready-Mixed Concrete
ASTM C136/C136M	(2019) Standard Test Method for Sieve Analysis of Fine and Coarse Aggregates
ASTM C138/C138M	(2023) Standard Test Method for Density (Unit Weight), Yield, and Air Content (Gravimetric) of Concrete
ASTM C143/C143M	(2020) Standard Test Method for Slump of Hydraulic-Cement Concrete
ASTM C150/C150M	(2022) Standard Specification for Portland Cement
ASTM C172/C172M	(2017) Standard Practice for Sampling Freshly Mixed Concrete
ASTM C173/C173M	(2023) Standard Test Method for Air Content of Freshly Mixed Concrete by the Volumetric Method
ASTM C231/C231M	(2024) Standard Test Method for Air Content of Freshly Mixed Concrete by the Pressure Method
ASTM C260/C260M	(2010a; R 2016) Standard Specification for Air-Entraining Admixtures for Concrete
ASTM C311/C311M	(2022) Standard Test Methods for Sampling and Testing Fly Ash or Natural Pozzolans for Use in Portland-Cement Concrete
ASTM C330/C330M	(2017a) Standard Specification for Lightweight Aggregates for Structural Concrete
ASTM C494/C494M	(2019; E 2022) Standard Specification for Chemical Admixtures for Concrete
ASTM C567/C567M	(2019) Determining Density of Structural Lightweight Concrete
ASTM C595/C595M	(2023) Standard Specification for Blended Hydraulic Cements
ASTM C618	(2023; E 2023) Standard Specification for Coal Fly Ash and Raw or Calcined Natural Pozzolan for Use in Concrete
ASTM C803/C803M	(2023) Standard Test Method for Penetration Resistance of Hardened Concrete
ASTM C845/C845M	(2018) Standard Specification for Expansive Hydraulic Cement
ASTM C873/C873M	(2015) Standard Test Method for Compressive Strength of Concrete Cylinders

Cast in Place in Cylindrical Molds

ASTM C900	(2015) Standard Test Method for Pullout Strength of Hardened Concrete
ASTM C920	(2018) Standard Specification for Elastomeric Joint Sealants
ASTM C989/C989M	(2022) Standard Specification for Slag Cement for Use in Concrete and Mortars
ASTM C1012/C1012M	(2018b) Standard Test Method for Length Change of Hydraulic-Cement Mortars Exposed to a Sulfate Solution
ASTM C1017/C1017M	(2013; E 2015) Standard Specification for Chemical Admixtures for Use in Producing Flowing Concrete
ASTM C1074	(2019) Standard Practice for Estimating Concrete Strength by the Maturity Method
ASTM C1077	(2017) Standard Practice for Agencies Testing Concrete and Concrete Aggregates for Use in Construction and Criteria for Testing Agency Evaluation
ASTM C1157/C1157M	(2023) Standard Performance Specification for Hydraulic Cement
ASTM C1218/C1218M	(2020c) Standard Test Method for Water-Soluble Chloride in Mortar and Concrete
ASTM C1240	(2020) Standard Specification for Silica Fume Used in Cementitious Mixtures
ASTM C1260	(2023) Standard Test Method for Potential Alkali Reactivity of Aggregates (Mortar-Bar Method)
ASTM C1293	(2008; R 2015) Standard Test Method for Determination of Length Change of Concrete Due to Alkali-Silica Reaction
ASTM C1567	(2023) Standard Test Method for Potential Alkali-Silica Reactivity of Combinations of Cementitious Materials and Aggregate (Accelerated Mortar-Bar Method)
ASTM C1602/C1602M	(2022) Standard Specification for Mixing Water Used in Production of Hydraulic Cement Concrete
ASTM D1751	(2018) Standard Specification for Preformed Expansion Joint Filler for Concrete Paving and Structural Construction (Nonextruding and Resilient Bituminous Types)

ASTM D1752	(2018) Standard Specification for Preformed Sponge Rubber, Cork and Recycled PVC Expansion Joint Fillers for Concrete Paving and Structural Construction
ASTM D2628	(1991; R 2016) Standard Specification for Preformed Polychloroprene Elastomeric Joint Seals for Concrete Pavements
ASTM D2835	(1989; R 2017) Standard Specification for Lubricant for Installation of Preformed Compression Seals in Concrete Pavements
ASTM D5759	(2012; R 2020) Characterization of Coal Fly Ash and Clean Coal Combustion Fly Ash for Potential Uses
ASTM D6690	(2015) Standard Specification for Joint and Crack Sealants, Hot Applied, for Concrete and Asphalt Pavements
ASTM E96/E96M	(2022a; E 2023) Standard Test Methods for Gravimetric Determination of Water Vapor Transmission Rate of Materials
ASTM E329	(2023) Standard Specification for Agencies Engaged in Construction Inspection, Testing, or Special Inspection
ASTM E1643	(2018a) Standard Practice for Selection, Design, Installation, and Inspection of Water Vapor Retarders Used in Contact with Earth or Granular Fill Under Concrete Slabs
ASTM E1745	(2017; R 2023) Standard Specification for Water Vapor Retarders Used in Contact with Soil or Granular Fill under Concrete Slabs

CONCRETE REINFORCING STEEL INSTITUTE (CRSI)

CRSI 10MSP	(2018) Manual of Standard Practice
CRSI RB4.1	(2016) Supports for Reinforcement Used in Concrete

NATIONAL INSTITUTE OF STANDARDS AND TECHNOLOGY (NIST)

NIST PS 1	(2009) DOC Voluntary Product Standard PS 1-07, Structural Plywood
-----------	---

U.S. ARMY CORPS OF ENGINEERS (USACE)

COE CRD-C 104	(1980) Method of Calculation of the Fineness Modulus of Aggregate
---------------	---

1.2 DEFINITIONS

Unless otherwise defined herein or in Contract Documents, ACI CT.

- a. "Cementitious material" as used herein must include pozzolans and hydraulic cements such as portland cement, fly ash, and slag cement.
- b. "Exposed to public view" means situated so that it can be seen from eye level from a public location after completion of the structure and surrounding structures such as fences or other buildings. A public location is accessible to persons not responsible for operation or maintenance of the structure.
- c. "Chemical admixtures" are liquids, or dispersible powders, used as an ingredient in a cementitious mixture to improve its economy and/or properties in the plastic and/or hardened state.
- d. "Supplementary cementitious materials" (SCM) are inorganic materials such as coal fly ash, silica fume, slag cement, natural or calcined pozzolans, and ultra-fine coal ash when used in such proportions to replace portland cement and reacts pozzolanically or hydraulically.
- e. "Design strength" (fc') is the specified compressive strength of concrete at time(s) specified in this section to meet structural design criteria.
- f. "Mass Concrete" (thermally-controlled concrete) is any concrete system that may approach a maximum temperature of 158 degrees F or may approach a maximum temperature difference between any two monitored locations of 36 degrees F without Contracting Officer written approval to exceed. In addition, it includes all concrete elements with a section thickness of greater than 3 feet regardless of temperature.
- g. "Mixture proportioning" is the process of designing concrete mixture proportions to enable it to meet the specified strength, service life and constructability requirements of the project using available materials while minimizing the initial and life-cycle cost.
- h. "Mixture proportions" are the masses or volumes of individual ingredients used to make a unit measure (cubic yard) of concrete.
- i. "Pozzolan" is a siliceous or silico-aluminous material that will, in finely divided form and in the presence of moisture, chemically react with calcium hydroxide at ordinary temperatures to form compounds having cementitious properties.
- j. "Workability" is the ease with which freshly mixed concrete or mortar can be mixed, placed, consolidated, and finished to a homogenous condition. Workability typically depends on water content, chemical admixtures, aggregate (shape and size distribution), cementitious materials content and age since batching (level of hydration).
- k. "Final Setting" is a degree of stiffening of a cementitious mixture where plasticity is lost sufficiently to resist the penetration of a weighted test device a specific distance; typically using a Vicat Apparatus.
- l. "Hard-troweled finish" is a finishing process which produces a hard, dense, and smooth surface by troweling in repeated right angle passes while increasing blade pressure on surface with each pass. Increased pressure is typically obtained by increasing trowel blade angle.

1.3 SUBMITTALS

Government approval is required for submittals with a "G" designation; submittals not having a "G" designation are for information only. Submittals with an "S" are for inclusion in the Sustainability eNotebook, in conformance with Section 01 33 29 SUSTAINABILITY REPORTING. Submit the following in accordance with Section 01 33 00 SUBMITTAL PROCEDURES:

SD-01 Preconstruction Submittals

Concrete Curing Plan
Quality Control Program; G
Quality Control Personnel Certifications; G
Quality Control Organizational Chart
Laboratory Accreditation; G
Cold Weather Plan; G
Hot Weather Plan; G
Maturity Method Data

SD-02 Shop Drawings

Reinforcing Steel; G
Placement Sequence and Jointing Plan; G

SD-03 Product Data

Joint Sealants
Joint Filler
Formwork Materials
Cementitious Materials
Vapor Barrier
Concrete Curing Materials
Reinforcement
Liquid Chemical Floor Hardeners and Sealers
Admixtures
Mechanical Reinforcing Bar Connectors
Local/Regional Materials
Biodegradable Form Release Agent

Pumping Concrete

SD-04 Samples

Mockup; G

SD-05 Design Data

Concrete Mixture Proportion; G

SD-06 Test Reports

Concrete Mixture Proportion; G

Fly Ash

Pozzolans

Silica Fume

Slag Cement

Aggregates

Compressive Strength Tests; G

Unit Weight of Structural Concrete

Air Content

Slump Tests

Water

SD-07 Certificates

Reinforcing Bars

Welder Qualifications

Silica Fume Manufacturer's Representative

VOC Content for Form Release Agents, Curing Compounds, and
Concrete Penetrating Sealers

Safety Data Sheets

Ready-mixed Concrete Manufacturer (Plant) and Trucks

Field Testing Technician and Testing Agency

SD-08 Manufacturer's Instructions

Liquid Chemical Floor Hardeners and Sealers

Joint Sealants; S

Curing Compounds

1.4 MODIFICATION OF REFERENCES

Accomplish work in accordance with ACI publications except as modified herein. Except for provisions associated with Contractor's means and methods or items delegated to the Contractor, such as formwork calculations, consider the non-mandatory, advisory or recommended provisions within ACI publications to be mandatory; where specific conflicts or options exist, request in writing a Contracting Officer determination. Interpret reference to the "Licensed Design Engineer," the "Licensed Design Professional," the "Building Official," the "Structural Engineer," and the "Architect/Engineer," or similar title to mean the Contracting Officer unless multiple roles or personnel are indicated in a specific requirement.

1.5 DELIVERY, STORAGE, AND HANDLING

Follow ACI 301, ACI 304R and ASTM A934/A934M requirements and recommendations. Do not deliver concrete until vapor barrier, forms, reinforcement, embedded items, and chamfer strips are in place and ready for concrete placement. Do not store opened containers of concrete curing compounds or sealers with materials that have a high capacity to adsorb volatile organic compound (VOC) emissions or in occupied spaces. Protect liquid admixtures and other liquid materials such as curing compounds and sealers from freezing and from temperature changes that would adversely affect their characteristics.

1.5.1 Reinforcement

Store reinforcement of different sizes and shapes in separate piles or racks raised above the ground and out of standing water to avoid excessive rusting. Protect from contaminants such as grease, oil, form release agent, and dirt. Ensure bar sizes can be accurately identified after bundles are broken and tags removed.

1.6 QUALITY ASSURANCE

1.6.1 Design Data

1.6.1.1 Concrete Mixture Proportion

Unless otherwise approved in writing by Contracting Officer, sixty days minimum prior to concrete placement, submit a mixture proportion for each class of concrete required in paragraph titled CONCRETE MIXTURE PROPORTION in PART 2. It is acceptable to submit a mixture proportion which meets multiple classes of concrete if properly identified. Submit all documentation required in ACI 301 Section 4 and as specified in this section. Submit a complete list of materials including type; brand; source and amount of cement, supplementary cementitious materials, and admixtures; and applicable reference specifications. Submit mill test and all other tests for cement, supplementary cementitious materials, aggregates, and admixtures. Provide documentation of maximum nominal aggregate size, gradation analysis, percentage retained and passing sieves, and a graph of percentage retained versus sieve size. Provide mixture proportion data using at least three different water-cementitious material ratios for each type of mixture, which produce a range of strength encompassing those required for each type of concrete required. If source material changes in quality or source, resubmit mixture proportion data using revised source material. Provide only materials that have been proven by trial

mixture studies to meet the requirements of this specification, unless otherwise approved in writing by the Contracting Officer. Indicate clearly in the submittal where each mixture proportion is used when more than one mixture proportion is submitted. Required average strength can be documented by field experience if field strength test data are available and represent a single group of at least 10 consecutive strength tests for one mixture, using materials and conditions similar to those expected for work, and encompassing a period of not less than 45 days. The average of field strength tests must equal or exceed fcr'. Changes in materials, conditions, and proportions within the test record shall not have been more closely restricted than those for the proposed work. Test records shall not be more than 24 months old. For previously approved concrete mixture proportions used within the past twelve months, the previous mixture proportion may be re-submitted without further trial batch testing if accompanied by material test data conducted within the last six months. Obtain mixture proportion approval from the Contracting Officer prior to concrete placement.

1.6.2 Shop Drawings

1.6.2.1 Reinforcing Steel

Indicate bending diagrams, assembly diagrams, splicing and laps of bars, shapes, dimensions, and details of bar reinforcing, accessories, and concrete cover. Do not scale dimensions from Contract Drawings to determine lengths of reinforcing bars. Reproductions of Contract Drawings are unacceptable.

1.6.3 Control Submittals

1.6.3.1 Concrete Curing Plan

Submit proposed materials, methods and duration for curing concrete elements in accordance with ACI 308.1.

1.6.3.2 Pumping Concrete

Submit proposed materials and methods for pumping concrete. Submittal must include mixture proportions, pumping equipment including type of pump and size and material for pipe, and maximum length and height concrete is to be pumped.

1.6.3.3 Silica Fume Manufacturer's Representative

The manufacturer's representative must be present at the concrete producer's plant to ensure proper mixture proportions are used, including high-range water-reducer, and batching methods during the first days of concrete mixture preparation and placement. After which the manufacturer's representative must designate a representative at the concrete producer's plant to ensure the concrete batching procedures meet the silica fume manufacturer's recommendations. Representative to attend and advise at finishing of sample slab.

1.6.3.4 VOC Content for form release agents, curing compounds, and concrete penetrating sealers

Submit certification for the form release agent, curing compounds, and concrete penetrating sealers that indicate the VOC content of each product.

1.6.3.5 Safety Data Sheets

Submit Safety Data Sheets (SDS) for all materials that are regulated for hazardous health effects. SDS must be readily accessible during each work shift for viewing.

1.6.4 Test Reports

1.6.4.1 Fly Ash and Pozzolans

Submit test results in accordance with ASTM C618 for fly ash and raw or calcined natural pozzolans. Submit test results performed within 6 months of submittal date.

1.6.4.2 Slag Cement

Submit test results in accordance with ASTM C989/C989M for slag cement. Submit test results performed within 6 months of submittal date.

1.6.4.3 Silica Fume

Submit test results in accordance with ASTM C1240 for silica fume. Submit test results performed within 6 months of submittal date.

1.6.4.4 Aggregates

Submit test results in accordance with ASTM C33/C33M, or ASTM C330/C330M for lightweight aggregate, and ASTM C1293, ASTM C1567, or ASTM C1260 as required in the paragraph titled ALKALI-AGGREGATE REACTION. As applicable, submit ASTM C1293 test results started within 5 years of submittal date on source aggregate. As applicable, submit ASTM C1567 or ASTM C1260 test results performed within 6 months of submittal date on source aggregate.

1.6.5 Quality Control Program

Develop and submit for approval a concrete quality control program in accordance with the guidelines of ACI 121R and as specified herein. The plan must include approved laboratories. Provide direct oversight for the concrete qualification program inclusive of associated sampling and testing. All quality control reports must be provided to the Contracting Officer, Quality Manager and Concrete Supplier. Maintain a hard copy or electronic copy of ACI SP-15 and CRSI 10MSP at project site.

1.6.5.1 Cold Weather Plan

Submit a Cold Weather Plan covering detailed procedures for concreting in cold weather in accordance with ACI 306.1.

1.6.5.2 Hot Weather Plan

Submit a Hot Weather Plan covering detailed procedures for concreting in hot weather in accordance with ACI 305.1.

1.6.6 Quality Control Personnel Certifications

The Contractor must submit for approval the responsibilities of the various quality control personnel, including the names and qualifications of the individuals in those positions and a quality control organizational chart defining the quality control hierarchy and the responsibility of the

various positions. Quality control personnel must be employed directly by the Contractor.

Submit American Concrete Institute certification for the following:

- a. CQC personnel responsible for inspection of concrete operations.
- b. Lead Foreman or Journeyman of the Concrete Placing, Finishing, and Curing Crews.
- c. Field Testing Technicians: ACI Concrete Field Testing Technician - Grade I.

Amendment 0003

1.6.6.1 Quality Manager Qualifications

The quality manager must **have** hold a current license as a professional engineer in a U.S. state or territory with experience on at least five similar projects. Evidence of extraordinary proven experience may be considered by the Contracting Officer as sufficient to act as the Quality Manager.

Amendment 0003

1.6.6.2 Field Testing Technician and Testing Agency

Submit data on qualifications of proposed testing agency and technicians for approval by the Contracting Officer. Obtain approval prior to performing testing on concrete.

- a. Work on concrete under this Contract must be performed by an ACI Concrete Field Testing Technician Grade 1 qualified in accordance with ACI MNL-2 or equivalent. Equivalent certification programs must include requirements for written and performance examinations as stipulated in ACI MNL-2.
- b. Testing agencies that perform testing services on reinforcing steel must meet the requirements of ASTM E329.
- c. Testing agencies that perform testing services on concrete materials must meet the requirements of ASTM C1077.

1.6.7 Laboratory Qualifications for Concrete Qualification Testing

The concrete testing laboratory must have the necessary equipment and experience to accomplish required testing. The laboratory must meet the requirements of ASTM C1077 and be Cement and Concrete Reference Laboratory (CCRL) inspected.

1.6.8 Laboratory Accreditation

Laboratory and testing facilities must be provided by and at the expense of the Contractor. The laboratories performing the tests must be accredited in accordance with ASTM C1077, including ASTM C78/C78M and ASTM C1260. The accreditation must be current and must include the required test methods, as specified. Furthermore, the testing must comply

with the following requirements:

- a. Aggregate Testing and Mixture Proportioning: Aggregate testing and mixture proportioning studies must be performed by an accredited laboratory and under the direction of a licensed design professional in a U.S. state or territory who is competent in concrete materials and must sign all reports and mixture proportion designs.
- b. Acceptance Testing: Furnish all materials, labor, and facilities required for molding, curing, testing, and protecting test specimens at the site and in the laboratory. Furnish and maintain boxes or other facilities suitable for storing and curing the specimens at the site while in the mold within the temperature range and moisture loss control stipulated by ASTM C31/C31M. Ensure uninhibited access to specimens at the site for monitoring and transportation to laboratory as needed.
- c. Contractor Quality Control: All sampling and testing must be performed by an approved, onsite, independent, accredited laboratory.

1.7 ENVIRONMENTAL REQUIREMENTS

Provide space ventilation according to material manufacturer recommendations, at a minimum, during and following installation of concrete curing compound and sealer. Maintain one of the following ventilation conditions during the curing period or for 72 hours after installation:

- a. Supply 100 percent outside air 24 hours a day.
- b. Supply airflow at a rate of 6 air changes per hour, when outside temperatures are between 55 degrees F and 84 degrees F and humidity is between 30 percent and 60 percent.
- c. Supply airflow at a rate of 1.5 air changes per hour, when outside air conditions are not within the range stipulated above.

1.7.1 Submittals for Environmental Performance

- a. Provide data indicating the percentage of post-industrial pozzolan (fly ash, slag cement) cement substitution as a percentage of the full product composite by weight.
- b. Provide data indicating the percentage of post-industrial and post-consumer recycled content aggregate.
- c. Provide product data indicating the percentage of post-consumer recycled steel content in each type of steel reinforcement as a percentage of the full product composite by weight.
- d. Provide product data stating the location where all products were manufactured
- e. For projects using FSC certified formwork, provide chain-of-custody documentation for all certified wood products.
- f. For projects using reusable formwork, provide data showing how formwork is reused.

- g. Provide SDS product information data showing that form release agents meet any environmental performance goals such as using vegetable and soy-based products.
- h. Provide SDS product information data showing that concrete adhesives meet any environmental performance goals including low emitting, low volatile organic compound products.

1.8 SUSTAINABLE DESIGN REQUIREMENTS

1.8.1 Local/Regional Materials

Use materials or products extracted, harvested, or recovered, as well as manufactured, within a 500 mile radius from the project site, if available from a minimum of three sources. See Section 01 33 29 SUSTAINABILITY REPORTING for cumulative total local material requirements. Concrete materials may be locally available. Submit documentation indicating distance between manufacturing facility and the project site. Indicate distance of raw material origin from the project site. Indicate relative dollar value of local/regional materials to total dollar value of products included in project.

1.8.2 Sustainable Strategies Compliance

This project has been designed using strategies from the USGBC's LEED® Building Design and Construction, Version 2009. The project will not be registered or go through review with the USGBC, but documentation related to credits addressed in the reference guide is required as directed in each specification section. In addition to the sustainable design requirements stated herein, refer to LEED Building Design & Construction, Version 2009 Reference guide for documentation guidance.

1.9 QUALIFICATIONS FOR WELDING WORK

Welding procedures must be in accordance with AWS D1.4/D1.4M.

Verify that Welder qualifications are in accordance with AWS D1.4/D1.4M for welding of reinforcement or under an equivalent qualification test approved in advance. Welders are permitted to do only the type of welding for which each is specifically qualified.

PART 2 PRODUCTS

2.1 FORMWORK MATERIALS

- a. Form-facing material in contact with concrete must be lumber, plywood, tempered concrete-form-grade hardboard, metal, plastic, or treated paper that creates specified appearance and texture of concrete surface. Submit product information on proposed form-facing materials if different from that specified herein.
- b. Design formwork, shores, reshores, and backshores to support loads transmitted to them and to comply with applicable building code requirements.
- c. Design formwork and shoring for load redistribution resulting from stressing of post-tensioned reinforcement. Ensure that formwork allows movement resulting from application of prestressing force.

- d. Design formwork to withstand pressure resulting from placement and vibration of concrete and to maintain specified tolerances.
- e. Design formwork to accommodate waterstop materials in joints at locations indicated in Contract Documents.
- f. Provide temporary openings in formwork if needed to facilitate placement, cleaning and inspection.
- g. Design formwork joints to inhibit leakage of mortar.
- h. Limit deflection of facing materials for concrete surfaces exposed to view to 1/240 of center-to-center spacing of facing supports.
- i. Unless shown on Contract Drawings, do not use earth cuts as forms for vertical or sloping surfaces.
- j. Submit product information on proposed form-facing materials if different from that specified herein.
- k. Submit procedure for reshoring and backshoring, including drawings signed and sealed by a licensed design engineer. Include on shop drawings the formwork removal procedure and magnitude of construction loads used for design of reshoring or backshoring system. Indicate in procedure the magnitude of live and dead loads assumed for required capacity of the structure at time of reshoring or backshoring.
- l. Submit manufacturer's product data on form liner proposed for use with each formed surface.

2.1.1.1 Wood Forms

Provide lumber that is square edged or tongue-and-groove boards, free of raised grain, knotholes, or other surface defects. Provide plywood that complies with NIST PS 1, B-B concrete form panels or better or AHA A135.4, hardboard for smooth form lining. Submit data verifying that composite wood products contain no urea formaldehyde resins.

2.1.1.1.1 Concrete Form Plywood (Standard Rough)

Provide plywood that conforms to NIST PS 1, B-B, concrete form, not less than 5/8-inch thick.

2.1.1.1.2 Overlaid Concrete Form Plywood (Standard Smooth)

Provide plywood that conforms to NIST PS 1, B-B, high density form overlay, not less than 5/8-inch thick.

2.1.2 Plastic Forms

Provide plastic forms that contain a minimum of 50 percent post-consumer recycled content, or a minimum of 50 percent post-industrial recycled content.

2.1.3 Carton Forms (Void Forms)

Moisture resistant treated paper faces, biodegradable, structurally sufficient to support weight of fresh concrete until final setting. Provide carton forms that contain a minimum of 10 percent post-consumer

recycled content, or a minimum of 20 percent post-industrial recycled content.

2.1.4 Steel Forms

Provide steel form surfaces that do not contain irregularities, dents, or sags.

2.2 FORMWORK ACCESSORIES

- a. Use commercially manufactured formwork accessories, including ties and hangers.
- b. Form ties and accessories must not reduce the effective cover of the reinforcement.

2.2.1 Form Ties

- a. Use form ties with ends or end fasteners that can be removed without damage to concrete.
- b. The breakback distance for ferrous ties must be at least 3/4 in. for Surface Finish-2.0 or Surface Finish-3.0, as defined in ACI 301.
- c. Submit manufacturer's data sheet on form ties.

2.2.2 Biodegradable Form Release Agent

- a. Provide form release agent that is colorless, biodegradable, and water-based, with a low (maximum of 55 grams/liter (g/l)) VOC content.
- b. Provide product that does not bond with, stain, or adversely affect concrete surfaces and does not impair subsequent treatments of concrete surfaces.
- c. Provide form release agent that reduces formwork moisture absorption, and does not contain diesel fuel, petroleum-based lubricating oils, waxes, or kerosene. Submit documentation indicating type of biobased material in product and biobased content.
- d. Submit manufacturer's product data on formwork release agent for use on each form-facing material.

2.2.3 Chamfer Materials

Unless noted otherwise, use lumber or plastic materials with dimensions of 3/4 x 3/4 in.

2.2.4 Construction and movement joints

- a. Submit details and locations of construction joints in accordance with the requirements herein.
- b. Locate construction joints within middle one-third of spans of slabs, beams, and girders. If a beam intersects a girder within the middle one-third of girder span, the distance between the construction joint in the girder and the edge of the beam must be at least twice the width of the larger member.

- c. For members with post-tensioning tendons, locate construction joints where tendons pass through centroid of concrete section.
- d. Locate construction joints in walls and columns at underside of slabs, beams, or girders and at tops of footings or slabs. Vertical joints in walls must be further away from corners and intersections than corner bars and other special reinforcement detailing.
- e. Make construction joints perpendicular to main reinforcement. Construction joint spacing must not exceed 60 feet without written approval of Contracting Officer. Slab sections must be divided into approximate squares where practicable.
- f. Provide movement joints where indicated in Contract Documents or in accepted alternate locations.
- g. Submit location and detail of movement joints if different from those indicated in Contract Documents.
- h. Submit manufacturer's data sheet on expansion joint materials.
- i. Provide keyways where indicated in Contract Documents. Longitudinal keyways indicated in Contract Documents must be at least 1-1/2 in. deep, measured perpendicular to the plane of the joint.

2.2.5 Other Embedded items

Use sleeves, inserts, anchors, and other embedded items of material and design indicated in Contract Documents. Where not indicated, use galvanized materials.

2.3 CONCRETE MATERIALS

2.3.1 Cementitious Materials

2.3.1.1 Portland Cement

- a. Unless otherwise specified, provide cement that conforms to ASTM C150/C150M Type I or II.
- b. Use one brand and type of cement for formed concrete having exposed-to-view finished surfaces.
- c. Supplier must certify that no hazardous waste is used in the fuel mix or raw materials.
- d. Submit information along with evidence demonstrating compliance with referenced standards. Submittals must include types of cementitious materials, manufacturing locations, shipping locations, and certificates showing compliance.
- e. Cementitious materials must be stored and kept dry and free from contaminants. Cementitious materials which have become caked or lumpy must not be used.
- f. High-early-strength portland cement. ASTM C150/C150M, Type III, low alkali. Use Type III cement only when approved in writing by Contracting Officer.

2.3.1.2 Blended Cements

- a. Blended cements must conform to ASTM C595/C595M Type IP, IS, or IT.
- b. Slag cement added to the Type IS blend must meet ASTM C989/C989M.
- c. The pozzolan added to the Type IS blend must meet ASTM C618 Class F and must be interground with the cement clinker. The manufacturer must state in writing that the amount of pozzolan in the finished cement will not vary more than plus or minus 5 mass percent of the finished cement from lot-to-lot or within a lot. The percentage and type of pozzolan used in the blend must not change from that submitted for the aggregate evaluation and mixture proportioning.

2.3.1.3 Fly Ash

- a. ASTM C618, Class F, except that the maximum allowable loss on ignition must not exceed 4 percent.
- b. If fly ash is used it shall range from 15 to 30 percent by weight of cementitious material, provided the fly ash does not reduce the amount of cement in the concrete mixture below the minimum requirements of local building codes. Where the use of fly ash cannot meet the minimum level, provide the maximum amount of fly ash permissible that meets the code requirements for cement content. Report the chemical analysis of the fly ash in accordance with ASTM C311/C311M. Evaluate and classify fly ash in accordance with ASTM D5759.

2.3.1.4 Slag cement

ASTM C989/C989M, Grade 100.

2.3.1.5 Silica Fume

Silica fume must conform to ASTM C1240, including the optional limits on reactivity with cement alkalis. Silica fume may be furnished as a dry, densified material or as slurry. A high-range water-reducing admixture (HRWRA) must be used with silica fume.

2.3.1.6 Other Supplementary Cementitious Materials

Natural pozzolan must be raw or calcined and conform to ASTM C618, Class N, including the optional requirement for uniformity.

Ultra Fine Fly Ash (UFFA) and Ultra Fine Pozzolan (UFP) must conform to ASTM C618, Class F or N, and the following additional requirements:

- a. The strength activity index at 28 days of age must be at least 95 percent of the control specimens.
- b. The average particle size must not exceed 6 microns.
- c. The sum of $SiO_2 + Al_2O_3 + Fe_2O_3$ must be greater than 77 percent.

2.3.2 Water

- a. Unless from a potable source, mixing water or ice must comply with the requirements of ASTM C1602/C1602M.

- b. Minimize the amount of water in the mixture. Improve workability by adjusting the aggregate gradation and using admixtures rather than by additional water in the mixture.
- c. Water must be potable; free from injurious amounts of oils, acids, alkalis, salts, organic materials, or other substances deleterious to concrete.
- d. Protect mixing water and ice from contamination during storage and delivery.

2.3.3 Aggregate

2.3.3.1 Normal-Weight Aggregate

- a. Aggregates must conform to ASTM C33/C33M unless otherwise specified in the Contract Documents or approved by the Contracting Officer.
- b. Aggregates used in concrete must be obtained from the same sources and have the same size range as aggregates used in concrete represented by submitted field test records or used in trial mixtures.
- c. Provide sand that is at least 50 percent natural sand unless otherwise required to meet ASR requirements and approved by Contracting Officer in writing.
- d. Store and handle aggregate in a manner that will avoid segregation and prevents contamination by other materials or other sizes of aggregates. Store aggregates in locations that will permit them to drain freely. Do not use aggregates that contain frozen lumps. Do not use bottom 6 inches of an aggregate pile if not stored on concrete slab.
- e. Submit types, pit or quarry locations, producers' names, aggregate supplier statement of compliance with ASTM C33/C33M, and ASTM C1293 expansion data not more than 18 months old.

2.3.4 Admixtures

- a. Chemical admixtures must conform to ASTM C494/C494M.
- b. Air-entraining admixtures must conform to ASTM C260/C260M.
- c. Chemical admixtures for use in producing flowing concrete must conform to ASTM C1017/C1017M.
- d. Do not use calcium chloride admixtures.
- e. If approved in writing by Contracting Officer, in lieu of rejecting aggregate source, use of an ASR-inhibiting admixture for concrete containing aggregate susceptible to ASR is acceptable if submitted with ASR testing per CONCRETE MIXTURE PROPORTION paragraph.
- f. Admixtures used in concrete must be the same as those used in the concrete represented by submitted field test records or used in trial mixtures.
- g. Protect stored admixtures against contamination, evaporation, or damage.

- h. To ensure uniform distribution of constituents, provide agitating equipment for admixtures used in the form of suspensions or unstable solutions. Protect liquid admixtures from freezing and from temperature changes that would adversely affect their characteristics.
- i. Submit types, brand names, producers' names, manufacturer's technical data sheets, and certificates showing compliance with standards required herein.

2.4 MISCELLANEOUS MATERIALS

2.4.1 Concrete Curing Materials

Provide concrete curing material in accordance with ACI 308.1 Section 2. Submit product data for concrete curing compounds and evaporation reducers, if used. Submit manufacturer's instructions for placement of curing compounds and evaporation reducers, if used.

2.4.2 Floor Finish Materials

2.4.2.1 Liquid Chemical Floor Hardeners and Sealers

- a. Hardener must be a colorless aqueous solution containing a blend of inorganic silicate or silicate material and proprietary components combined with a wetting agent; that penetrates, hardens, and densifies concrete surfaces. Submit manufacturer's instructions for placement of liquid chemical floor hardener.
- b. Use concrete penetrating sealers with a low (maximum 100 grams/liter, less water and less exempt compounds) VOC content. Submit manufacturer's instructions for placement of sealers.

2.4.3 Expansion/Contraction Joint Filler

ASTM D1751 or ASTM D1752 Type I or Type II. Material must be 1/2 inch thick, unless otherwise indicated.

2.4.4 Joint Sealants

2.4.4.1 Horizontal Surfaces, 3 Percent Slope, Maximum

ASTM D6690 or ASTM C920, Type M, Class 25, Use T.

2.4.4.2 Vertical Surfaces Greater Than 3 Percent Slope

ASTM C920, Type M, Grade NS, Class 25, Use T.

2.4.4.3 Preformed Polychloroprene Elastomeric Type

ASTM D2628.

2.4.4.4 Lubricant for Preformed Compression Seals

ASTM D2835.

2.4.5 Vapor Barrier

ASTM E1745 Class C polyethylene sheeting, minimum 15 mil thickness or

other equivalent material with a maximum permeance rating of 0.01 perms per ASTM E96/E96M.

2.5 CONCRETE MIXTURE PROPORTION

2.5.1 Properties and Requirements

- a. Use materials and material combinations listed in this section and the Contract Documents.
- b. Cementitious material content must be adequate for concrete to satisfy the specified requirements for strength, water to cementitious materials ratio (w/cm), durability, workability, and finishability described in this section and rest of the Contract Documents.
- c. Selected target slump must meet the requirements this section, the Contract Documents, and must not exceed 9 in. Concrete must not show visible signs of segregation.
- d. The target slump must be enforced for the duration of the project. Determine the slump at the point of placement after conveyance by ASTM C143/C143M. Slump tolerances must meet the requirements of ACI 117.
- e. The nominal maximum size of coarse aggregate for a mixture in a given portion of the structure must not exceed three-fourths of the minimum clear spacing between reinforcement, one-fifth of the narrowest dimension between sides of forms, or one-third of the thickness of slabs or toppings.
- f. Concrete must be air entrained for portions of the structure assigned to Exposure Class F1, F2, or F3. The total air content must be in accordance with the requirements of the paragraph titled DURABILITY.
- g. Measure air content at the point of placement after conveyance in accordance with ASTM C173/C173M or ASTM C231/C231M.
- h. Concrete for slabs to receive a hard-troweled (burnished) finish must not contain an air-entraining admixture or have a total air content greater than 3 percent.
- i. Concrete properties and requirements for each portion of the structure are specified in the table below and define the specified classes of concrete. Refer to the paragraph titled DURABILITY for more details on exposure categories and their requirements. If a portion of the structure is either not defined or could be included in multiple categories within the table, Contractor must either use the more severe requirements or request a written determination from the Contracting Officer. Transition areas within the same placement must use the more severe requirements. For differences in requirements between the following table those requirements listed in paragraph titled DURABILITY, the most stringent will control.

Concrete Class	Minimum f_c' psi [^]	Exposure Categories	Miscellaneous Requirements
Footings and , foundations; not subject to hard-troweled finish	4000 at 28 days	S1; C1; W1; F0	Max. slump:6 in. Nominal maximum aggregate size must be 1 in.
Exterior Slabs	4000 at 28 days	S1;C1;W1;F1	Max. Slump: 6 in. Nominal maximum aggregate size must be 1 in.
Walls	4000 at 28 days	S1; C1; W1; F0	Max. slump: 6in. Nominal maximum aggregate size must be 1 in.
Interior slabs-on-ground	4000 at 28 days	S1; C1; W0; F0	Max slump: 6 in. Nominal maximum aggregate size must be 3/4 in.

[^]Minimum f_c' based on cylinder test specimens as indicated in paragraph titled COMPRESSIVE STRENGTH TESTS.

2.5.2 Durability

2.5.2.1 Alkali-Aggregate Reaction

Do not use any aggregate susceptible to alkali-carbonate reaction (ACR). Use one of the three options below to qualify concrete mixtures to reduce the potential of alkali-silica reaction (ASR):

- a. For each aggregate used in concrete, the expansion result determined in accordance with ASTM C1293 must not exceed 0.04 percent at one year unless a pozzolan or slag cement is used, which the limit is then 0.04 percent at two years.

- b. For each aggregate used in concrete, the expansion result of the aggregate and cementitious materials combination determined in accordance with ASTM C1567 must not exceed 0.10 percent at an age of 16 days. Aggregates must be tested individually.
- c. For each aggregate used in concrete, the expansion result determined in accordance with ASTM C1260 must not exceed 0.10 percent at an age of 16 days.

2.5.2.2 Freezing and Thawing Resistance

- a. Provide concrete meeting the following requirements based on exposure class assigned to portions of the structure for freezing-and-thawing exposure in Contract Documents:

Exposure class	Maximum <i>w/cm</i> *	Minimum <i>fc'</i> , psi^	Total Air content	Additional Requirements
F0	0.45	4000		N/A
F1	0.45	4000	Depends on aggregate size	N/A
F2	0.45	4500	Depends on aggregate size	See limits on maximum cementitious material by mass
F3	0.40	5000	Depends on aggregate size	See limits on maximum cementitious material by mass
F3 plain concrete	0.45	4500	Depends on aggregate size	See limits on maximum cementitious material by mass

*The maximum *w/cm* limits do not apply to lightweight concrete.

^Minimum *fc'* based on cylinder test specimens as indicated in paragraph titled COMPRESSIVE STRENGTH TESTS.

- b. Concrete must contain an air-entraining admixture for portions of the structure assigned to Exposure Class F1, F2, or F3, except slabs to receive a hard-troweled finish. The total air content must meet the requirements of the following table:

Nominal maximum aggregate size, in.	Total air content, percent**^	
	Exposure Class F2 and F3	Exposure Class F1
3/8	7.5	6.0
1/2	7.0	5.5
3/4	6.0	5.0
1	6.0	4.5
1-1/2	5.5	4.5
2	5.0	4.0
3	5.5	3.5

*Tolerance on total air content as measured in paragraph titled FIELD QUALITY CONTROL must be plus/minus 1.5 percent.

^For minimum fc' greater than 5000 psi, reducing air content by 1.0 percentage point is acceptable with Contracting Officer written approval.

- c. Submit documentation verifying compliance with specified requirements.
- d. For sections of the structure that are assigned Exposure Class F3, submit certification on cement composition verifying that mixture proportion meets the requirements of the following table:

Cementitious material	Maximum percent of total cementitious material by mass*
Fly ash or other pozzolans conforming to ASTM C618	25
Slag cement conforming to ASTM C989/C989M	50
Silica fume conforming to ASTM C1240	10
Total of fly ash or other pozzolans, slag cement, and silica fume	50^
Total of fly ash or other pozzolans and silica fume	35^

*Total cementitious material also includes ASTM C150/C150M, ASTM C595/C595M, ASTM C845/C845M, and ASTM C1157/C1157M cement. The maximum percentages above must include:

- i. Fly ash or other pozzolans present in ASTM C1157/C1157M or ASTM C595/C595M Type IP blended cement.
- ii. Slag cement present in ASTM C1157/C1157M or ASTM C595/C595M Type

IS blended cement.

iii. Silica fume conforming to ASTM C1240 present in ASTM C1157/C1157M or ASTM C595/C595M Type IP blended cement.

^Fly ash or other pozzolans and silica fume must constitute no more than 25 percent and 10 percent, respectively, of the total mass of the cementitious materials.

2.5.2.3 Corrosion and Chloride Content

- a. Provide concrete meeting the requirements of the following table based on the exposure class assigned to portions of the structure requiring protection against reinforcement corrosion in Contract Documents.
- b. Submit documentation verifying compliance with specified requirements.
- c. Water-soluble chloride ion content contributed from constituents including water, aggregates, cementitious materials, and admixtures must be determined for the concrete mixture by ASTM C1218/C1218M at age between 28 and 42 days.
- d. The maximum water-soluble chloride ion (Cl-) content in concrete, percent by mass of cement is as follows:

Exposure class	Maximum w/cm*	Minimum fc', psi^	Maximum water-soluble chloride ion (CL-) content in concrete, percent by mass of cement
Reinforced concrete			
C0	0.45	4000	1.00
C1	0.45	4000	0.30
C2	0.4	5000	0.15
Prestressed concrete			
C0	0.45	4000	0.06
C1	0.45	4000	0.06
C2	0.4	5000	0.06

*The maximum w/cm limits do not apply to lightweight concrete.

^Minimum fc' based on cylinder test specimens as indicated in paragraph titled COMPRESSIVE STRENGTH TESTS.

- e. Concrete cast against galvanized stay-in-place forms, including permanent metal decking, must meet chloride ion limits of exposure class C1 unless more stringent limits are required in this paragraph.

2.5.2.4 Sulfate Resistance

- a. Provide concrete meeting the requirements of the following table based on the exposure class assigned to portions of the structure for sulfate exposure.

Exposure class	Maximum w/cm	Minimum fc', psi^^	Required cementitious materials-types			Calcium chloride admixture
			ASTM C150/C150M	ASTM C595/C595M	ASTM C1157/C1157M	
S0	0.45	4000	N/A	N/A	N/A	No
S1	0.45	4000	II*^	IP(MS); IS(<70)(MS); IT(MS)	MS	No restrictions
S2	0.45	4500	V^	IP(HS); IS(<70)(HS); IT(HS)	HS	Not permitted
S3	0.45	4500	V + pozzolan or slag cement**	IP(HS)+ pozzolan or slag cement^; IS (<70)(HS) + pozzolan or slag cement^; IT (HS) + pozzolan or slag cement**	HS + pozzolan or slag cement**	Not permitted
S3	0.40	5000	v***	Types with (HS) designation	HS	Not permitted

* For seawater exposure, other types of portland cements with tricalcium aluminate (C3A) contents up to 10 percent are acceptable if the w/cm does not exceed 0.40.

** The amount of the specific source of the pozzolan or slag cement to be used shall be at least the amount determined by test or service record to improve sulfate resistance when used in concrete containing Type V cement. Alternatively, the amount of the specific source of the pozzolan or slag used shall not be less than the amount tested in accordance with ASTM C1012/C1012M and meeting the requirements maximum expansion requirements listed herein.

*** If Type V cement is used as the sole cementitious material, the optional sulfate requirement of 0.040 percent maximum expansion in ASTM C150/C150M shall be required.

^ Other available types of cement, such as Type III or Type I, are

acceptable in exposure classes S1 or S2 if the C3A contents are less than 8 or 5 percent, respectively.

^^Minimum fc' based on cylinder test specimens as indicated in paragraph titled COMPRESSIVE STRENGTH TESTS

- b. The maximum w/cm limits for sulfate exposure do not apply to lightweight concrete.
- c. Alternative combinations of cementitious materials of those listed in this paragraph are acceptable if they meet the maximum expansion requirements listed in the following table:

Exposure class	Maximum expansion when tested using ASTM C1012/C1012M		
	At 6 months	At 12 months	At 18 months
S1	0.10 percent	N/A	N/A
S2	0.05 percent	0.10 percent^	N/A
S3	N/A	N/A	0.10 percent

^The 12-month expansion limit applies only when the measured expansion exceeds the 6-month maximum expansion limit.

2.5.2.5 Concrete Temperature

The temperature of concrete as delivered must not exceed 95°F.

2.5.2.6 Concrete permeability

- a. Provide concrete meeting the requirements of the following table based on exposure class assigned to portions of the structure requiring low permeability in the Contract Documents.

Exposure class	Maximum w/cm*	Minimum fc', psi^	Additional minimum requirements
W0	0.45	4000	None
W1	0.45	4000	ACI 318 Para. 26.4.2.2(d) & Paragraph titled Alkali-Aggregate Reaction

Exposure class	Maximum w/cm*	Minimum fc', psi^	Additional minimum requirements
W2	0.4	4000	ACI 318 Para. 26.4.2.2(d) & Paragraph titled Alkali-Aggregate Reaction

*The maximum w/cm limits do not apply to lightweight concrete.

^Minimum fc' based on cylinder test specimens as indicated in paragraph titled COMPRESSIVE STRENGTH TESTS.

b. Submit documentation verifying compliance with specified requirements.

2.5.3 Contractor's Option for Material Only

At the option of the Contractor, those applicable material sections of DOT RBS for Class A strength concrete must govern in lieu of this specification for concrete. Do not change the selected option during the course of the work.

2.5.4 Trial Mixtures

Trial mixtures, as needed, must be in accordance to ACI 301.

2.5.5 Ready-Mix Concrete

Unless otherwise approved in writing by the Contracting Officer, ready-mixed concrete must be supplied by a ready-mixed concrete manufacturer (plant) and trucks which are certified by the National Ready Mixed Concrete Association's (NRMCA) Plant and Truck Certification Program. Submit current plant and truck certifications. Provide concrete that meets the requirements of ASTM C94/C94M. Contractor must coordinate with ready-mixed concrete manufacturer any adjustments required to meet requirements in paragraph titled FIELD QUALITY CONTROL for sampling at point of placement after conveyance.

Ready-mixed concrete manufacturer must provide duplicate delivery tickets with each load of concrete delivered to the project site. Provide delivery tickets with the following optional information in addition to the required information per ASTM C94/C94M:

- a. Type, and brand, and amount of cement
- b. Type, brand and, amount of other cementitious materials, if used
- c. Maximum size of aggregate
- d. Amount and brand name of admixtures, if used
- e. Type, brand, and amount of fiber reinforcement, if used

2.6 REINFORCEMENT

- a. Shop bend reinforcement cold. Fabricate reinforcement in accordance

with fabricating tolerances of ACI 117.

- b. Submit manufacturer's certified test report for reinforcement.
- c. Submit placing drawings showing fabrication dimensions and placement locations of reinforcement and reinforcement supports. Placing drawings must indicate locations of splices, lengths of lap splices, and details of mechanical and welded splices. Submission of Contract Drawings as placing drawings will not be acceptable.
- d. Submit request with locations and details of splices not indicated in Contract Documents.
- e. Submit request to place column dowels without using templates, if desired.
- f. If desired, submit request and procedure to field-bend or straighten reinforcing bars partially embedded in concrete at locations not indicated in Contract Documents. Field bending or straightening of reinforcing bars once per bend location is permitted where indicated in the Contract Documents:
- g. Submit request for field cutting, including location and type of bar to be cut and reason field cutting is required. Reinforcement must not be cut without written approval from Contracting Officer.

2.6.1 Reinforcing Bars

- a. Reinforcing bars must be deformed, except spirals, load-transfer dowels, and welded wire reinforcement, which may be plain.
- b. ASTM A615/A615M with the bars marked S, Grade 60; or ASTM A996/A996M with the bars marked R, Grade 60, or marked A, Grade 60. See Section 01 33 29 SUSTAINABILITY REQUIREMENTS AND REPORTING for cumulative total recycled content requirements.
- c. Reinforcing bars may contain post-consumer or post-industrial recycled content. Submit documentation indicating percentage of post-industrial and post-consumer recycled content per unit of product. Indicate relative dollar value of recycled content products to total dollar value of products included in project.
- d. Submit mill certificates for reinforcing bars.

2.6.2 Mechanical Reinforcing Bar Connectors

- a. Provide 125 percent minimum yield strength of the reinforcement bar.
- b. Mechanical splices for galvanized reinforcing bars must be galvanized or coated with dielectric material.
- c. Mechanical splices used with epoxy-coated or dual-coated reinforcing bars must be coated with dielectric material.
- d. Submit data on mechanical splices demonstrating compliance with this paragraph.

2.6.3 Wire

- a. See Section 01 33 29 SUSTAINABILITY REPORTING for cumulative total recycled content requirements. Wire reinforcement may contain post-consumer or post-industrial recycled content. Provide flat sheets of welded wire reinforcement. Rolls of wire reinforcement must not be used.
- b. Plain or deformed steel wire must conform to ASTM A1064/A1064M.

2.6.4 Welded Wire Reinforcement

- a. Use welded wire reinforcement specified in Contract Documents and conforming to one or more of the specifications given herein.
- b. Plain welded wire reinforcement must conform to ASTM A1064/A1064M, with welded intersections spaced no greater than 12 in. apart in direction of principal reinforcement.
- c. Deformed welded wire reinforcement must conform to ASTM A1064/A1064M, with welded intersections spaced no greater than 16 in. apart in direction of principal reinforcement.

2.6.5 Reinforcing Bar Supports

- a. Provide reinforcement support types within structure as required by Contract Documents. Reinforcement supports must conform to CRSI RB4.1. Submit description of reinforcement supports and materials for fastening coated reinforcement if not in conformance with CRSI RB4.1. Pre-soaked precast concrete blocks (dobies) of similar concrete strength or steel reinforcement standees are acceptable for slabs-on-ground.
- b. Legs of supports in contact with formwork must be plastic, hot-dip galvanized, or plastic coated after fabrication, or stainless-steel bar supports. Leg design must minimize visibility on finished surface.
- c. See Section 01 33 29 SUSTAINABILITY REPORTING for cumulative total recycled content requirements. Plastic and steel may contain post-consumer or post-industrial recycled content.

2.6.6 Dowels for Load Transfer in Floors

Provide lightly oiled dowels for load transfer in floors of the type, design, weight, and dimensions indicated in Contract Documents. Provide dowel bars that are plain-billet steel conforming to ASTM A615/A615M, Grade 40. Provide dowel pipe that is steel conforming to ASTM A53/A53M. Alternate products manufactured and sold as dowels for load transfer may be used with written approval by Contracting Officer if they provide at least an equivalent capacity.

Plate dowels must conform to ASTM A36/A36M, and must be of size and spacing equivalent to dowel bars shown in Contract Documents. Plate dowel system must minimize shrinkage restraint by using a tapered shape.

2.6.7 Welding

- a. Provide weldable reinforcing bars that conform to ASTM A706/A706M and ASTM A615/A615M and Supplement S1, Grade 60, except that the maximum

carbon content must be 0.55 percent.

- b. Comply with AWS D1.4/D1.4M unless otherwise specified. Do not tack weld reinforcing bars.
- c. Welded assemblies of steel reinforcement produced under factory conditions, such as welded wire reinforcement, bar mats, and deformed bar anchors, are allowed.
- d. After completing welds on zinc-coated (galvanized), epoxy-coated, or zinc and epoxy dual-coated reinforcement, coat welds and repair coating damage as previously specified.

PART 3 EXECUTION

3.1 EXAMINATION

- a. Do not begin installation until substrates have been properly constructed; verify that substrates are level, properly compacted, and not inundated with water. Concrete must not be placed on frozen subgrade.
- b. If substrate preparation is the responsibility of another installer, notify Contracting Officer of unsatisfactory preparation before processing.
- c. Check field dimensions before beginning installation. If variations from design dimensions do not allow proper installation, notify Contracting Officer and wait for instructions before beginning installation.

3.2 PREPARATION

Determine quantity of concrete needed and minimize the production of excess concrete. Designate locations or uses for potential excess concrete before the concrete is batched.

3.2.1 General

- a. Surfaces against which concrete is to be placed must be free of debris, loose material, standing water, snow, ice, and other deleterious substances before start of concrete placing.
- b. Remove standing water without washing it over freshly deposited concrete.

3.2.2 Subgrade Under Foundations and Footings

- a. When subgrade material is semi-porous and dry, sprinkle subgrade surface with water to a saturated surface dry condition at the time concrete is deposited, or seal subgrade surface by covering surface with specified vapor retarder if approved by Contracting Officer in writing.
- b. When subgrade material is porous, seal subgrade surface by covering surface with specified vapor retarder.

3.2.3 Subgrade Under Slabs on Ground

- a. Before construction of slabs on ground, have underground work on pipes, conduits, and other installations completed and approved.
- b. Previously constructed subgrade or fill must be cleaned of foreign materials
- c. Finish surface of capillary water barrier under interior slabs on ground must not show deviation in excess of 1/4 inch when tested with a 10-foot straightedge parallel with and at right angles to building lines.
- d. Finished surface of subgrade or fill under exterior slabs on ground must not be more than 0.02-foot above or 0.10-foot below elevation indicated.

3.2.4 Edge Forms and Screed Strips for Slabs

- a. Set edge forms or bulkheads and intermediate screed strips for slabs to obtain indicated elevations and contours in finished slab surface. Materials must be strong enough to support vibrating bridge screeds or roller pipe screeds if nature of specified slab finish requires use of such equipment.
- b. Align concrete surface to elevation of screed strips by use of strike-off templates or approved compacting-type screeds.

3.2.5 Reinforcement and Other Embedded Items

- a. Secure reinforcement, joint materials, and other embedded materials in position. Items must be inspected, and approved before start of concrete placing.
- b. When concrete is placed, reinforcement must be free of materials deleterious to bond. Reinforcement with rust, mill scale, or a combination of both will be considered satisfactory, provided minimum nominal dimensions, nominal weight, and minimum average height of deformations of a hand-wire-brushed test specimen are not less than applicable ASTM specification requirements.
- c. Contractor must not weld to embedded materials in concrete which is less than 14 days old without written Contracting Officer approval. If approved, appropriate measures must be taken during welding to avoid damage to the surrounding concrete.

3.3 FORMS

- a. Provide forms, shoring, and scaffolding for concrete placement. Set forms mortar-tight and true to line and grade.
- b. Chamfer above ground exposed joints, edges, and external corners of concrete 0.75 inch. Place chamfer strips in corners of formwork to produce beveled edges on permanently exposed surfaces. Do not bevel reentrant corners or edges of formed joints of concrete unless shown on Contract Documents.
- c. Provide formwork with clean-out openings as needed to permit inspection and removal of debris.

- d. Inspect formwork and remove foreign material before concrete is placed.
- e. At construction joints, lap form-facing materials over the concrete of previous placement. Ensure formwork is placed against hardened concrete so offsets at construction joints conform to specified tolerances.
- f. Provide positive means of adjustment (such as wedges or jacks) of shores and struts. Do not make adjustments in formwork after concrete has reached initial setting.
- g. Fasten form wedges in place after final adjustment of forms and before concrete placement.
- h. Provide anchoring and bracing to control upward and lateral movement and instability of formwork system.
- i. Construct formwork for openings to facilitate removal and to produce opening dimensions as specified and within tolerances.
- j. Provide runways for moving equipment. Support runways directly on formwork or structural members. Do not support runways on reinforcement. Loading applied by runways must not exceed capacity of formwork or structural members.
- k. Position and support expansion joint materials, waterstops, and other embedded items to prevent displacement during concrete placement. Fill voids in sleeves, inserts, and anchor slots temporarily with removable material or cover sufficiently to prevent concrete entry into voids.
- l. Clean surfaces of formwork and embedded materials of dried mortar, grout, and foreign materials before concrete placement.
- m. Concrete cast against galvanized stay-in-place forms, including permanent metal decking, must meet chloride ion limits of exposure class C1 unless more stringent limits are required in paragraph titled CONCRETE MIXTURE PROPORTION.

3.3.1 Coating

- a. Cover formwork surfaces with an acceptable material that inhibits bond with concrete.
- b. If formwork release agent is used, apply to formwork surfaces in accordance with manufacturer's recommendations before placing reinforcement. Remove excess release agent on formwork prior to concrete placement.
- c. Do not allow formwork release agent to contact reinforcement or hardened concrete against which fresh concrete is to be placed. Cleaning of materials deleterious to bond off of reinforcement must be complete prior to ordering concrete.

3.3.2 Reshoring

- a. Do not allow structural members to be loaded with combined dead and construction loads in excess of loads indicated in the accepted

procedure.

- b. Install and remove reshores or backshores in accordance with accepted procedure.
- c. For floors supporting shores under newly placed concrete, either leave original supporting shores in place, or install reshores or backshores. Shoring system and supporting slabs must resist anticipated loads. Locate reshores and backshores directly under a shore position or as indicated on formwork shop drawings.
- d. In multistory buildings, place reshoring or backshoring over a sufficient number of stories to distribute weight of newly placed concrete, forms, and construction live loads.

3.3.3 Reuse

- a. Reuse of forms is acceptable providing the structural integrity of concrete and the aesthetics of exposed concrete are not compromised.
- b. Wood forms must not be clogged with paste and must be capable of absorbing high water-cementitious material ratio paste.
- c. Remove leaked mortar from formwork joints before reuse.

3.3.4 Forms for Standard Rough Form Finish

Provide formwork in accordance with ACI 301 Section 5 with a surface finish, SF-1.0, for formed surfaces that are to be concealed by other construction, will be in an inaccessible area when construction is complete, or will be in an area which is not designed for regular human occupancy such as the inside of a liquid-filled tank or crawl space.

3.3.5 Forms for Standard Semi-Smooth Form Finish

Provide formwork in accordance with ACI 301 Section 5 with a surface finish, SF-2.0, for formed surfaces that are exposed to view but not public view. Use this surface finish if not otherwise specified.

3.3.6 Forms for Standard Smooth Form Finish

Provide formwork in accordance with ACI 301 Section 5 with a surface finish, SF-3.0, for formed surfaces that are exposed to public view. Provide a mockup of the concrete surface appearance and texture.

3.3.7 Form Ties

- a. For post-tensioned structures, do not remove formwork supports until stressing records have been accepted by the Contracting Officer.
- b. After ends or end fasteners of form ties have been removed, repair tie holes in accordance with ACI 301 Section 5 requirements.

3.3.8 Forms for Concrete Pan Joist Construction

Pan-form units for one-way or two-way concrete joist and slab construction must be factory-fabricated units of the approximate section indicated. Units must consist of steel or molded fiberglass concrete form pans. Closure units must be furnished as required.

3.3.9 Tolerances for Form Construction

- a. Construct formwork so concrete surfaces conform to tolerances in ACI 117.
- b. Position and secure sleeves, inserts, anchors, and other embedded items such that embedded items are positioned within ACI 117 tolerances.
- c. To maintain specified elevation and thickness within tolerances, install formwork to compensate for deflection and anticipated settlement in formwork during concrete placement. Set formwork and intermediate screed strips for slabs to produce designated elevation, camber, and contour of finished surface before formwork removal. If specified finish requires use of vibrating screeds or roller pipe screeds, ensure that edge forms and screed strips are strong enough to support such equipment.

3.3.10 Removal of Forms and Supports

- a. If vertical formed surfaces require finishing, remove forms as soon as removal operations will not damage concrete.
- b. Remove top forms on sloping surfaces of concrete as soon as removal will not allow concrete to sag. Perform repairs and finishing operations required. If forms are removed before end of specified curing period, provide curing and protection.
- c. Do not damage concrete during removal of vertical formwork for columns, walls, and sides of beams. Perform needed repair and finishing operations required on vertical surfaces. If forms are removed before end of specified curing period, provide curing and protection.
- d. Form-facing material and horizontal facing support members may be removed before in-place concrete reaches specified compressive strength if shores and other supports are designed to allow facing removal without deflection of supported slab or member.

3.3.11 Strength of Concrete Required for Removal of Formwork

If removal of formwork, reshoring, or backshoring is based on concrete reaching a specified in-place strength, mold and field-cure cylinders in accordance with ASTM C31/C31M. Test cylinders in accordance with ASTM C39/C39M. Alternatively, use one or more of the methods listed herein to evaluate in-place concrete strength for formwork removal.

- a. Tests of cast-in-place cylinders in accordance with ASTM C873/C873M. This option is limited to slabs with concrete depths from 5 to 12 in.
- b. Penetration resistance in accordance with ASTM C803/C803M.
- c. Pullout strength in accordance with ASTM C900.
- d. Maturity method in accordance with ASTM C1074. Submit maturity method data using project materials and concrete mixture proportions used on the project to demonstrate the correlation between maturity and compressive strength of laboratory cured test specimens to the

Contracting Officer.

3.4 PLACING REINFORCEMENT AND MISCELLANEOUS MATERIALS

- a. Unless otherwise specified, placing reinforcement and miscellaneous materials must be in accordance to ACI 301. Provide bars, welded wire reinforcement, wire ties, supports, and other devices necessary to install and secure reinforcement.
- b. Reinforcement must not have rust, scale, oil, grease, clay, or foreign substances that would reduce the bond. Rusting of reinforcement is a basis of rejection if the effective cross-sectional area or the nominal weight per unit length has been reduced. Remove loose or scaled rust prior to placing steel. Well adhered rust may remain. Tack welding is prohibited.
- c. Nonprestressed cast-in-place concrete portions of the structure must have concrete cover for reinforcement given in the following table unless noted otherwise in Contract Documents::

Concrete Exposure	Portion of Structure	Reinforcement	Specified cover, in.
Cast against and permanently in contact with ground	All	All	3
Exposed to weather, including outdoors under cover, or in contact with ground in completed construction	All	No. 6 through No. 18 bars	2
		No. 5 bar, W31 or D31 wire, and smaller	1-1/2
Not exposed to weather or in contact with ground in completed construction	Slabs, joists, and walls	No. 14 and No. 18 bars	1-1/2
		No. 11 bar and smaller	1
	Beams, columns, pedestals, and tension ties	Primary reinforcement, stirrups, ties, spirals, and hoops	1-1/2

- d. Precast nonprestressed or prestressed concrete elements manufactured under plant conditions must have concrete cover for reinforcement,

ducts, and end fittings given in the following table:

Concrete Exposure	Element	Reinforcement	Specified cover, in.
Exposed to weather, including outdoors under cover, or in contact with ground in completed construction; located in high-humidity or corrosive environments	Walls	No. 14 and No. 18 bars; tendons larger than 1-1/2 in. diameter	1-1/2
		No. 11 bars and smaller; W31 and D31 wire, and smaller; tendons and strands 1-1/2 in.	1
	All other	No. 14 and No. 18 bars; tendons larger than 1-1/2 in.	2
		No. 6 through No. 11 bars; tendons and strands larger than 5/8 in. diameter through 1-1/2 in.	1-1/2
		No. 5 bar, W31 or D31 wire, and smaller; tendons and strands 5/8 in. diameter and smaller	1-1/4

Concrete Exposure	Element	Reinforcement	Specified cover, in.
Not exposed to weather or in contact with ground	Slabs, joists, and walls	No. 14 and No. 18 bars; tendons larger than 1-1/2 in. diameter	1-1/4
		Tendons and strands 1-1/2 in. diameter and smaller	3/4
		No. 11 bar, W31 or D31	5/8
	Beams, columns, pedestals, and tension ties	Primary reinforcement	Greater of bar diameter and 5/8 and need not exceed 1-1/2
		Stirrups, ties, spirals, and hoops	3/8

3.4.1 General

Provide details of reinforcement that are in accordance with the Contract Documents.

3.4.2 Vapor Barrier

- a. Install in accordance with ASTM E1643. Provide beneath the on-ground concrete floor slab. Use the greatest widths and lengths practicable to eliminate joints wherever possible. Lap joints a minimum of 12

inches and tape.

- b. Remove torn, punctured, or damaged vapor barrier material and provide with new vapor barrier prior to placing concrete. Concrete placement must not damage vapor barrier material. Place vapor barrier directly on underlying subgrade, base course, or capillary water barrier, unless it consists of crushed material or large granular material which could puncture the vapor barrier. In this case, a thin layer of approximately 13 mm 1/2 inch of fine graded material should be rolled or compacted over the fill before installation of the vapor barrier to reduce the possibility of puncture. Control concrete placement so as to prevent damage to the vapor barrier.

3.4.3 Reinforcement Supports

Provide reinforcement support in accordance with CRSI RB4.1 and ACI 301 Section 3 requirements. Supports for coated or galvanized bars must also be coated with electrically compatible material for a distance of at least 2 inches beyond the point of contact with the bars.

3.4.4 Splicing

As indicated in the Contract Documents. For splices not indicated follow ACI 301. Do not splice at expected points of maximum stress and stagger adjacent splices. If needed, request general written guidance for expected points of maximum stress from Contracting Officer. Overlap welded wire reinforcement the spacing of the cross wires, plus 2 inches.

3.4.5 Future Bonding

Plug exposed, threaded, mechanical reinforcement bar connectors with a greased bolt. Provide bolt threads that match the connector. Countersink the connector in the concrete. Caulk the depression after the bolt is installed.

3.4.6 Setting Miscellaneous Material

Place and secure anchors and bolts, pipe sleeves, conduits, and other such items in position before concrete placement and support against displacement. Plumb anchor bolts and check location and elevation. Temporarily fill voids in sleeves with readily removable material to prevent the entry of concrete.

3.4.7 Fabrication

Shop fabricate reinforcing bars to conform to shapes and dimensions indicated for reinforcement, and as follows:

- a. Provide fabrication tolerances that are in accordance with ACI 117.
- b. Provide hooks and bends that are in accordance with the Contract Documents.

Reinforcement must be bent cold to shapes as indicated. Bending must be done in the shop. Rebending of a reinforcing bar that has been bent incorrectly is not permitted. Bending must be in accordance with standard approved practice and by approved machine methods.

Deliver reinforcing bars bundled, tagged, and marked. Tags must be metal

with bar size, length, mark, and other information pressed in by machine. Marks must correspond with those used on the placing drawings.

Do not use reinforcement that has any of the following defects:

- a. Bar lengths, depths, and bends beyond specified fabrication tolerances
- b. Bends or kinks not indicated on drawings or approved shop drawings
- c. Bars with reduced cross-section due to rusting, inadvertent cutting, or other cause

Replace defective reinforcement with new reinforcement having required shape, form, and cross-section area.

3.4.8 Placing Reinforcement

Place reinforcement in accordance with ACI 301.

For slabs on ground (over earth or over capillary water barrier) and for footing reinforcement, support bars or welded wire reinforcement on precast concrete units (dobies) or standees, spaced at intervals required by size of reinforcement, to keep reinforcement the minimum height specified above the underside of slab or footing.

For slabs other than on ground, supports for which any portion is less than 1 inch from concrete surfaces that are exposed to view or to be painted must be of plastic (designed for such use), precast concrete units (dobies), plastic-coated steel, or stainless steel protected bar supports. Precast concrete units must be wedge shaped (dog boned), not larger than 3-1/2 by 3-1/2 inches, and of dimension equal to that indicated for concrete protection of reinforcement. If used, provide precast units that have cast-in galvanized tie wire hooked for anchorage and blend with concrete surfaces after finishing is completed.

Provide reinforcement that is supported and secured together to prevent displacement by construction loads or by placing of fresh concrete, and as follows:

- a. Provide supports for reinforcing bars that are sufficient in number and have sufficient strength to carry the reinforcement they support, and in accordance with ACI 301 and CRSI 10MSP. Do not use supports to support runways for concrete conveying equipment and similar construction loads.
- b. Equip supports on ground and similar surfaces with sand-plates if needed.
- c. Support welded wire reinforcement as required for reinforcing bars.
- d. Secure reinforcements to supports by means of tie wire. Unless otherwise specified wire must be black, soft iron wire, not less than 16 gage.
- e. Reinforcement must be accurately placed, securely tied at intersections, and held in position during placing of concrete by spacers, chairs, or other approved supports. Point wire-tie ends away from the form. Unless otherwise indicated, numbers, type, and spacing of supports must conform to the Contract Documents.

- f. Bending of reinforcing bars partially embedded in concrete is permitted only as specified in the Contract Documents.

3.4.9 Spacing of Reinforcing Bars

- a. Spacing must be as indicated in the Contract Documents.
- b. Reinforcing bars may be relocated to avoid interference with other reinforcement, or with conduit, pipe, or other embedded items. If any reinforcing bar is moved a distance exceeding one bar diameter or specified placing tolerance, resulting rearrangement of reinforcement is subject to written preapproval by the Contracting Officer.

3.4.10 Concrete Protection for Reinforcement

Additional concrete protection (i.e. increased concrete cover) must be in accordance with the Contract Documents.

3.4.11 Welding

Welding must be in accordance with AWS D1.4/D1.4M.

3.5 BATCHING, MEASURING, MIXING, AND TRANSPORTING CONCRETE

In accordance with ASTM C94/C94M, ACI 301, ACI 302.1R and ACI 304R, except as modified herein. Batching equipment must be such that the concrete ingredients are consistently measured within the following tolerances: 1 percent for cement and water, 2 percent for aggregate, and 3 percent for admixtures. Furnish mandatory batch ticket information for each load of ready-mix concrete.

3.5.1 Measuring

Make measurements at intervals as specified in paragraph titled FIELD QUALITY CONTROL.

3.5.2 Mixing

- a. Mix concrete in accordance with ASTM C94/C94M, ACI 301 and ACI 304R.
- b. Machine mix concrete. Begin mixing within 30 minutes after the cement has been added to the aggregates. Place concrete within 90 minutes of either addition of mixing water to cement and aggregates or addition of cement to aggregates. If discharge is acceptable after more than 90 minutes the air content, slump, and concrete temperature shall be tested and shall be within the specified limits. A retarder shall be used to facilitate placing and finishing when concrete temperature is 85 degrees F or greater.
- c. If the total air content falls below the specified limit, add a sufficient quantity of air-entraining admixture, within the manufacturer's recommended dosage, to bring the total air content within the specified limits. Using additional drum revolutions to raise total air content percentage is not acceptable. If the total air content is above the specified limit including tolerances, the batch must be rejected. Dissolve admixtures in the mixing water and mix in the drum to uniformly distribute the admixture throughout the batch. Do not reconstitute concrete that has begun to solidify.

- d. When fibers are used, add fibers together with the aggregates and never as the first component in the mixer. Fibers must be dispensed into the mixing system using appropriate dispensing equipment and procedure as recommended by the manufacturer. Contractor quality control must visually inspect each batch of concrete at project site to ensure fibers have been added and are well dispersed prior to placement.

3.5.3 Transporting

Transport concrete from the mixer to the forms as rapidly as practicable. Prevent segregation or loss of ingredients. Clean transporting equipment thoroughly before each batch. Do not use aluminum pipe or chutes. Remove concrete which has segregated or reached initial setting in transporting and dispose of as directed.

3.6 PLACING CONCRETE

Place concrete in accordance with ACI 301 Section 5. Concrete shall be placed within 15 minutes of discharge into non-agitating equipment.

3.6.1 Pumping

ACI 304R and ACI 304.2R. Pumping must not result in separation or loss of materials nor cause interruptions sufficient to permit loss of plasticity between successive increments. Loss of slump in pumping equipment must not exceed 2 inches at discharge/placement. Do not convey concrete through pipe made of aluminum or aluminum alloy. Avoid rapid changes in pipe sizes. Limit maximum size of coarse aggregate to 33 percent of the diameter of the pipe unless well-rounded aggregate is used; if so, limit maximum coarse aggregate size to 40 percent of the pipe diameter. If Contracting Officer approval is given to sample at point of delivery to project site instead of specified point of placement, avoid extreme boom angles or truck positions which significantly alter fresh concrete properties such as total air content and slump.

3.6.2 Cold Weather

Cold weather concrete must meet the requirements of ACI 301 unless otherwise specified. Do not allow concrete temperature to decrease below 50 degrees F. Obtain approval prior to placing concrete when the ambient temperature is below 40 degrees F or when concrete is likely to be subjected to freezing ambient temperatures within 24 hours. Cover concrete and provide sufficient heat to maintain 50 degrees F minimum adjacent to both the formwork and the structure while curing. Limit the rate of cooling to 37 degrees F in any 1 hour and 50 degrees F per 24 hours after heat application.

3.6.3 Hot Weather

Hot weather concrete must meet the requirements of ACI 305.1 unless otherwise specified. Maintain required concrete temperature or use other means while following Figure 4.2 in ACI 305R to prevent the evaporation rate from exceeding 0.2 pounds of water per square foot of exposed concrete per hour. Use suitable means to control concrete temperature, prevent rapid drying of newly placed concrete, and limit plastic shrinkage cracking. In hot weather, use initial curing measures per ACI 308.1 between placement and finishing. Start final curing measures when the

surface of the fresh concrete is sufficiently hard to permit curing without damage, typically immediately following final finishing. Provide water hoses, pipes, spraying equipment, and water hauling equipment if the job site is remote to a water source and a wet curing method is used. Unless an alternate method is approved in writing by Contracting Officer, provide burlap cover or other suitable permeable material with fogging or continuous wetting of the concrete in hot weather when project conditions prevent the use of either liquid membrane curing compound or impervious sheets. For vertical surfaces in hot weather, protect forms from direct sunlight or otherwise cool them, and drip water from the top of structure once concrete is placed.

3.6.4 Bonding

Surfaces of set concrete at joints, must be roughened and cleaned of laitance, coatings, loose particles, and foreign matter. Roughen surfaces in a manner that exposes the aggregate uniformly and does not leave laitance, loosened particles of aggregate, nor damaged concrete such as micro-cracking (i.e. bruising) at the surface.

Obtain bonding of fresh concrete to concrete that has set as follows:

- a. At joints between footings and walls or columns, between walls or columns and the beams or slabs they support, and elsewhere unless otherwise specified; roughened and cleaned surface of set concrete must be dampened, but not saturated, immediately prior to placing of fresh concrete.
- b. At joints in exposed-to-view work; at vertical joints in walls; at joints near midpoint of span in girders, beams, supported slabs, other structural members; in work designed to contain liquids; the roughened and cleaned surface of set concrete must be dampened but not saturated and covered with a cement grout coating.
- c. Provide cement grout that consists of equal parts of portland cement and fine aggregate by weight with not more than 6 gallons of water per 94-pound sack of cement. Apply cement grout with a stiff broom or brush to a minimum thickness of 1/16 inch. Deposit fresh concrete before cement grout has attained its initial set.

3.7 WASTE MANAGEMENT

Provide as specified in the Waste Management Plan and as follows.

3.7.1 Mixing Equipment

Before concrete batching, designate on-site area to be paved later in project for cleaning out concrete mixing trucks. Minimize water used to wash equipment.

3.7.2 Hardened, Cured Waste Concrete

Crush and reuse hardened, cured waste concrete as fill or as a base course for pavement.

3.7.3 Reinforcing Steel

Collect waste reinforcing steel and place in designated area for recycling.

3.7.4 Other Waste

Identify concrete manufacturer's or supplier's policy for collection or return of construction waste, unused material, deconstruction waste, and/or packaging material. Return excess cement to supplier. Institute deconstruction and construction waste separation and recycling for use in manufacturer's programs. When such a program is not available, seek local recyclers to reclaim the materials.

3.8 SURFACE FINISHES EXCEPT FLOOR, SLAB, AND PAVEMENT FINISHES

3.8.1 Defects

Repair surface defects in accordance with ACI 301 Section 5.

3.8.2 Not Against Forms (Top of Walls)

Surfaces not otherwise specified must be finished with wood floats to even surfaces. Finish must match adjacent finishes.

3.8.3 Formed Surfaces

3.8.3.1 Tolerances

Tolerances in accordance with ACI 117 and as indicated.

3.8.3.2 As-Cast Rough Form

Provide for surfaces that are to be concealed by other construction, will be in an inaccessible area when construction is complete, or will be in an area which is not designed for regular human occupancy such as the inside of a liquid-filled tank or crawl space a surface finish SF-1.0 per ACI 301. Patch holes and defects in accordance with ACI 301.

3.8.3.3 Standard Semi-Smooth Finish

Provide for surfaces that are exposed to view but not public view a surface finish SF-2.0 per ACI 301. Use this surface finish for formed surfaces if not otherwise specified. Patch holes, including bug holes, and defects in accordance with ACI 301.

3.8.3.4 Standard Smooth Finish

Provide for surfaces exposed to public view a surface finish SF-3.0 per ACI 301. Patch holes, including bug holes, and defects in accordance with ACI 301.

3.9 FLOOR, SLAB, AND PAVEMENT FINISHES AND MISCELLANEOUS CONSTRUCTION

In accordance with ACI 301 and ACI 302.1R, unless otherwise specified. Slope floors uniformly to drains where drains are provided. Steel trowel and fine-broom finish concrete slabs that are to receive quarry tile, ceramic tile, or paver tile. Where straightedge measurements are specified, Contractor must provide straightedge.

3.9.1 Finish

Place, consolidate, and immediately strike off concrete to obtain proper contour, grade, and elevation before bleedwater appears. Permit concrete

to attain a set sufficient for floating and supporting the weight of the finisher and equipment. If bleedwater is present prior to floating the surface, drag the excess water off or remove by absorption with porous materials. Do not use dry cement to absorb bleedwater. Grate tampers ("jitterbugs") shall not be used.

3.9.1.1 Scratched

Use for surfaces intended to receive bonded applied cementitious applications. Finish concrete in accordance with ACI 301 Section 5 for a scratched finish.

3.9.1.2 Floated

Use for exterior slabs where not otherwise specified and as indicated in Contract Documents. Finish concrete in accordance with ACI 301 Section 5 for a floated finish.

3.9.1.3 Steel Troweled

Use for interior floors intended as walking surfaces, and for reception of floor coverings, and as indicated in Contract Documents. Finish concrete in accordance with ACI 301 Section 5 for a steel troweled finish. Do not hard-trowel, or burnish, the surface unless indicated in the Contract Documents.

3.9.1.4 Broomed

Use on surfaces of exterior walks, platforms, patios, and ramps, unless otherwise indicated. Finish concrete in accordance with ACI 301 Section 5 for a broomed finish. Direction of grooves must be consistent and orthogonal to any slope. Request written determination from Contracting Officer on direction or pattern if needed.

3.9.1.5 Pavement

Screed the concrete with a template which is advanced with a combined longitudinal and crosswise motion. Maintain a slight surplus of concrete ahead of the template. After screeding, float the concrete longitudinally. Use a straightedge to check slope and flatness; correct and refloat as necessary. Obtain final finish by a burlap drag. Drag a strip of clean, wet burlap from 3 to 10 feet wide and 2 feet longer than the pavement width across the slab. Produce a fine, granular, sandy textured surface without disfiguring marks. Round edges and joints with an edger having a radius of 1/8 inch.

3.9.2 Concrete Walks

Provide 4 inches thick minimum. Provide contraction joints spaced every 5 linear feet unless otherwise indicated. Cut contraction joints 1 inch deep, or one fourth the slab thickness whichever is deeper, with a jointing tool after the surface has been finished. Provide 0.5 inch thick transverse expansion joints at changes in direction where sidewalk abuts curb, steps, rigid pavement, or other similar structures; space expansion joints every 50 feet maximum. Give walks a broomed finish. Unless indicated otherwise, provide a transverse slope of 1/48. Limit variation in cross section to 1/4 inch in 5 feet.

3.9.3 Pits and Trenches

Place bottoms and walls monolithically or provide waterstops and shear keys.

3.9.4 Curbs and Gutters

Provide contraction joints spaced every 10 feet maximum unless otherwise indicated. Cut contraction joints 3/4 inch deep with a jointing tool after the surface has been finished. Provide expansion joints 1/2 inch thick and spaced every 100 feet maximum unless otherwise indicated. Perform pavement finish.

3.9.5 Splash Blocks

Provide at outlets of downspouts emptying at grade. Splash blocks may be precast concrete, and must be 24 inches long, 12 inches wide and 4 inches thick, unless otherwise indicated, with smooth-finished countersunk dishes sloped to drain away from the building.

3.10 JOINTS

3.10.1 Construction Joints

Submit a Placement Sequence and Jointing Plan indicating locations and types of joints and sequence of placement for each element. Make and locate joints not indicated so as not to impair strength and appearance of the structure, as approved. Joints must be perpendicular to main reinforcement. Reinforcement must be continued and developed across construction joints. Locate construction joints as follows:

3.10.1.1 Construction Joints for Constructability Purposes

- a. In walls, at top of footing; at top of slabs on ground; at top and bottom of door and window openings or where required to conform to architectural details; and at underside of deepest beam or girder framing into wall.
- b. In columns or piers, at top of footing; at top of slabs on ground; and at underside of deepest beam or girder framing into column or pier.
- c. Near midpoint of spans for supported slabs, beams, and girders unless a beam intersects a girder at the center, in which case construction joints in girder must offset a distance equal to twice the width of the beam. Make transfer of shear through construction joint by use of inclined reinforcement.

Unless otherwise detailed in Contract Documents, provide keyways at least 1-1/2-inches deep in construction joints in walls and slabs and between walls and footings; approved bulkheads may be used for slabs.

3.10.2 Isolation Joints in Slabs on Ground

- a. Provide joints at points of contact between slabs on ground and vertical surfaces, such as column pedestals, foundation walls, grade beams, and elsewhere as indicated.
- b. Fill joints with premolded joint filler strips 1/2 inch thick, extending full slab depth. Install filler strips at proper level

below finish floor elevation with a slightly tapered, dress-and-oiled wood strip temporarily secured to top of filler strip to form a groove not less than 3/4 inch in depth where joint is sealed with sealing compound and not less than 1/4 inch in depth where joint sealing is not required. Remove wood strip after concrete has set. Contractor must clean groove of foreign matter and loose particles after surface has dried.

3.10.3 Contraction Joints in Slabs on Ground

- a. Provide joints to form panels as indicated.
- b. Under and on exact line of each control joint, cut 50 percent of welded wire reinforcement and other reinforcement before placing concrete.
- c. Sawcut contraction joints into slab on ground in accordance with ACI 301 Section 5.

3.10.4 Sealing Joints in Slabs on Ground

- a. Contraction and control joints which are to receive finish flooring material must be sealed with joint sealing compound after concrete curing period. Slightly underfill groove with joint sealing compound to prevent extrusion of compound. Remove excess material as soon after sealing as possible.
- b. Sealed groove must be left ready to receive filling material that is provided as part of finish floor covering work.

3.11 CURING AND PROTECTION

Curing and protection in accordance with ACI 308.1 Section 5, unless otherwise specified and subject to approval by the Contracting Officer. Begin curing immediately following final finishing unless earlier initial curing is needed, see ACI 308.1 and paragraph titled HOT WEATHER. Avoid damage to concrete from nearby vibration created by blasting, pile driving, movement of equipment in the vicinity, disturbance of formwork or protruding reinforcement, and any other activity resulting in vibrations. Protect concrete from premature drying, excessively hot or cold temperatures, and injurious action by sun, rain, flowing water, freezing precipitation, mechanical injury, load stresses, heavy shock, tire marks, and oil stains. Do not allow concrete to dry out during placement through the expiration of the specified curing period. Do not use membrane-forming compound on surfaces where appearance would be objectionable, on any surface to be painted, where coverings are to be bonded to the concrete, or on concrete to which other concrete is to be bonded. If forms are removed prior to the expiration of the curing period, provide another curing procedure specified herein for the remaining portion of the curing period. Provide moist curing for those areas receiving liquid chemical sealer, hardener, or epoxy coating. Allow curing compound/sealer installations to cure prior to the installation of materials that adsorb VOCs.

3.11.1 Requirements for Type III, High-Early-Strength Portland Cement

The curing periods are required to be not less than one-fourth of those specified for portland cement, but in no case less than 72 hours.

3.11.2 Curing Periods

ACI 308.1, except 10 days for retaining walls, pavement or chimneys.

3.11.3 Curing Formed Surfaces

Accomplish curing of formed surfaces, including undersurfaces of girders, beams, supported slabs, and other similar surfaces by moist curing with forms in place for full curing period or until forms are removed. If forms are removed before end of curing period, accomplish final curing of formed surfaces by any of the curing methods specified above, as applicable.

3.11.4 Curing Unformed Surfaces

- a. Accomplish initial curing of unformed surfaces, such as monolithic slabs, floor topping, and other flat surfaces, by curing methods specified. Submit evaporation reducers for approval if used. Do not apply membrane curing compound prior to final finishing or work into surface during finishing. Do not use finishing aids without written approval by Contracting Officer and only then in strict adherence to manufacturer's printed instructions.
- b. Accomplish final curing of unformed surfaces by any of curing methods specified, as applicable.
- c. Accomplish final curing of concrete surfaces to receive liquid floor hardener of finish flooring by moisture-retaining cover curing.

3.11.5 Temperature of Concrete During Curing

When temperature of atmosphere is 41 degrees F and below, maintain temperature of concrete at not less than 55 degrees F throughout concrete curing period or 45 degrees F when the curing period is measured by maturity. When necessary, make arrangements before start of concrete placing for heating, covering, insulation, or housing as required to maintain specified temperature and moisture conditions for concrete during curing period.

When the ambient temperature is 80 degrees F and above or during other climatic conditions which may cause rapid drying of concrete, make arrangements before start of concrete placing for installation of wind breaks, of shading, or for fogging, wet sprinkling, or moisture-retaining covering of light color as required to protect concrete during curing period.

Changes in temperature of concrete must be uniform and not exceed 37 degrees F in any 1 hour nor 80 degrees F in any 24-hour period.

3.11.6 Protection After Curing

Protect finished concrete surfaces from damage by construction operations.

3.12 FIELD QUALITY CONTROL

3.12.1 Aggregate Testing

3.12.1.1 Fine Aggregate

At least once during each shift when the concrete plant is operating, there must be one sieve analysis and fineness modulus determination in accordance with ASTM C136/C136M and COE CRD-C 104 for the fine aggregate or for each fine aggregate if it is batched in more than one size or classification. The location at which samples are taken may be selected by the Contractor as the most advantageous for control. However, the Contractor is responsible for delivering fine aggregate to the mixer within specification limits. When the amount passing on any sieve is outside the specification limits, the fine aggregate must be immediately resampled and retested. If there is another failure on any sieve, the fact must be immediately reported to the Contracting Officer, concreting must be stopped, and immediate steps taken to correct the grading.

3.12.1.2 Coarse Aggregate

At least once during each shift in which the concrete plant is operating, there must be a sieve analysis in accordance with ASTM C136/C136M for each size of coarse aggregate. The location at which samples are taken may be selected by the Contractor as the most advantageous for production control. However, the Contractor must be responsible for delivering the aggregate to the mixer within specification limits. A test record of samples of aggregate taken at the same locations must show the results of the current test as well as the average results of the five most recent tests including the current test. The Contractor may adopt limits for control coarser than the specification limits for samples taken other than as delivered to the mixer to allow for degradation during handling. When the amount passing any sieve is outside the specification limits, the coarse aggregate must be immediately resampled and retested. If the second sample fails on any sieve, that fact must be reported to the Contracting Officer. Where two consecutive averages of 5 tests are outside specification limits, the operation must be considered out of control and reported to the Contracting Officer. Concreting must be stopped and immediate steps must be taken to correct the grading.

3.12.2 Sampling

ASTM C172/C172M. Collect samples of fresh concrete to perform tests specified. Sampling must be at point of placement after conveyance unless written approval by Contracting Officer is obtained for sampling at point of delivery to the project site, such as at the end of ready-mix concrete truck chute. If sampling at point of delivery to the project site is approved, Contractor must perform correlation testing using the most detrimental configurations between point of placement and point of delivery to project site to ensure as-placed concrete will meet this specification. ASTM C31/C31M for making test specimens.

3.12.3 Testing

3.12.3.1 Slump Tests

ASTM C143/C143M. Take concrete samples during concrete placement/discharge. The maximum slump may be increased as specified with the addition of an approved admixture provided that the approved

water-cementitious material ratio is not exceeded. Perform tests at commencement of concrete placement, when test cylinders are made, and for every 16 20 cubic yards (maximum) of concrete unless written approval for an alternate sampling frequency is obtained from the Contracting Officer.

3.12.3.2 Temperature Test

Test the concrete whenever slump testing is performed.

3.12.3.3 Compressive Strength Tests

ASTM C39/C39M. Use either 4 inch by 8 inch or 6 inch by 12 inch test cylinders, except the cylinder diameter must be at least three times the nominal maximum coarse aggregate size used. Depending on cylinder size selected, make either twelve 4 inch by 8 inch or eight 6 inch by 12 inch test cylinders for each set of tests in accordance with ASTM C31/C31M, ASTM C172/C172M and applicable requirements of ACI 305R and ACI 306R. Take precautions at project site to prevent temperatures beyond the specified range and loss of water from each specimen. Either three 4 inch by 8 inch or two 6 inch by 12 inch cylinders is considered a strength test set. Test one set at 7 days, one set at 28 days, and hold two sets in reserve to be tested at the discretion of the Contracting Officer. All tests must be performed on the same sized cylinders for the duration of the project.

Take samples for strength tests of each mixture proportion and for 100 CY concrete placed each day not less than once a day, nor less than once for each 100 cubic yards of concrete for the first 250 cubic yards placed on the project, then every 100 cubic yards thereafter if no strength tests are found to be deficient, nor less than once for each 5400 square feet of surface area for slabs or walls. If any strength test is found to be deficient within first 250 cubic yards placed on the project, continue sampling at higher rate until 250 cubic yards of concrete is tested satisfactory, unless otherwise approved by Contracting Officer. Concrete compressive strength tests must meet the requirements of this section, the Contract Documents, and ACI 301.

The compressive strength of the concrete tested will be considered satisfactory when the 28-day averages of all sets of three consecutive strength tests equal or exceed the specified compressive strength, f_c' , and no individual strength test result falls below the specified minimum compressive strength by more than 500 psi if f_c' is 5000 psi or less, or by more than $0.10f_c'$ if f_c' is greater than 5000 psi. If any 28-day compressive strength test fails to reach 70 percent of specified minimum compressive strength, immediately inform Contracting Officer and investigate cause of low strength and potential to impact future placements; make interim corrections as needed.

3.12.3.4 Air Content

ASTM C173/C173M or ASTM C231/C231M for normal weight concrete. Test air-entrained concrete or concrete to receive a hard-troweled finish for total air content at the same frequency as specified for slump tests.

3.12.3.5 Unit Weight of Structural Concrete

ASTM C567/C567M and ASTM C138/C138M. Determine unit weight of lightweight and normal weight concrete. Perform test whenever slump testing is performed.

3.12.3.6 Strength of Concrete Structure

The strength of a specific portion of the concrete structure will be considered deficient if any of the following conditions are identified within that portion of the structure:

- a. Failure to meet compressive strength tests as evaluated.
- b. Reinforcement not conforming to requirements specified.
- c. Concrete which differs from required dimensions or location in such a manner as to reduce strength.
- d. Concrete curing and protection of concrete against temperature extremes during curing not conforming to requirements specified.
- e. Concrete subjected to damaging mechanical disturbances, particularly load stresses, heavy shock, and excessive vibration.
- f. At the Contracting Officer's written determination based on documented evidence, poor workmanship likely to result in deficient strength.

Where the strength of the concrete structure is considered deficient submit a mitigation or remediation plan for review and written approval by the Contracting Officer.

3.12.3.7 Non-Conforming Materials

Factors that indicate that there are non-conforming materials include (but not limited to) excessive compressive strength, inadequate compressive strength, excessive slump, excessive voids and honeycombing, excessive segregation, significant cold joints or pour lines, concrete delivery records that indicate excessive time between mixing and placement, or excessive water was added to the mixture during delivery and placement. Any of these indicators alone are sufficient reason for the Contracting Officer to request additional sampling and testing.

Investigations into non-conforming materials must be conducted at the Contractor's expense. The Contractor must be responsible for the investigation and must make written recommendations to adequately mitigate or remediate the non-conforming material. The Contracting Officer may accept, accept with reduced payment, require mitigation, or require removal and replacement of non-conforming material at no additional cost to the Government.

3.12.3.8 Testing Concrete Structure for Strength

When there is evidence that strength of in-place concrete in a portion of the structure does not meet specification requirements or there are non-conforming materials, perform the following:

- a. Determine approximate location of suspect concrete and control work in area. Do not further build upon or conceal potentially deficient concrete. Non-destructive testing methods, such as rebound hammer or pulse-velocity, may be used to locate suspect areas but must not be used to evaluate in-place strength or determine acceptance/rejection.
- b. Review test specimen casting, storage, and testing operations to

ensure compliance with ASTM C31/C31M. Additionally, determine likelihood of deficient in-place strength. Report findings to Contracting Officer.

- c. Request written determination from Contracting Officer if structural adequacy is unacceptably reduced through a review of calculations and other structural analysis or new analysis.

If additional investigation is required as determined by the Contracting Officer based on both the likelihood of unacceptable in-place concrete strength and analysis indicating structural adequacy is significantly reduced, make cores drilled from hardened concrete for compressive strength determination in accordance with ASTM C42/C42M, and as follows:

- a. Take at least three representative cores from each portion of the in-place concrete that is considered potentially deficient. Location of cores will be determined by the Contracting Officer. Locate reinforcement where practicable and avoid cutting it when drilling.
- b. Test cores after moisture conditioning, in accordance with ASTM C42/C42M.
- c. Strength of cores from each tested portion of the structure are considered satisfactory if their average compressive strength is equal to or greater than 85 percent of the 28-day design compressive strength of the class of concrete, and if no single core strength is less than 75 percent of the specified minimum compressive strength of the class of concrete. Unless otherwise approved in writing by the Contracting Officer, erratic core test results, as defined by ASTM C42/C42M single-operator precision statement except adjusted up from 9 percent based on number of cores per ACI 214.4R Table 7.1 (i.e. 10.6 percent range from average for 3 cores), must be neglected and additional core testing performed to replace erratic core test results.
- d. Core specimens will be taken and tested by the Government. If the results of core tests indicate that the in-place concrete as placed does not conform to the Contract Documents, the cost of such tests and restoration required must be borne by the Contractor.

Fill core holes solid with patching mortar and finished to match adjacent concrete surfaces.

Correct concrete work that is found inadequate by core tests in a manner approved by the Contracting Officer. Concrete with adequate strength may still be found unacceptable by Contracting Officer due to reduced service life or other non-conforming materials, see paragraphs titled NON-CONFORMING MATERIALS and REPAIR, REHABILITATION AND REMOVAL.

3.13 REPAIR, REHABILITATION AND REMOVAL

Before the Contracting Officer accepts the structure the Contractor must inspect the structure for cracks, damage and substandard concrete placements that may adversely affect the service life of the structure. A report documenting these defects must be prepared which includes recommendations for repair, removal or remediation must be submitted to the Contracting Officer for approval before any corrective work is accomplished.

3.13.1 Repair of Weak Surfaces

Weak surfaces are defined as mortar-rich, rain-damaged, uncured, or containing exposed voids or deleterious materials. Concrete surfaces with weak surfaces less than 1/4 inch thick must be diamond ground to remove the weak surface. Surfaces containing weak surfaces greater than 1/4 inch thick must be removed and replaced or mitigated in a manner acceptable to the Contracting Officer.

3.13.2 Failure of Quality Assurance Test Results

Proposed mitigation efforts by the Contractor must be approved by the Contracting Officer prior to proceeding.

-- End of Section --

TABLE OF CONTENTS

VOLUME 1 OF 4

CHECKLIST FOR PREPARATION OF OFFERS
TABLE OF CONTENTS

CONTRACT CLAUSES

	STANDARD FORM 1442
	BIDDING SCHEDULE
	EXPLANATION OF BID ITEMS
	LIMITATIONS ON SUBCONTRACTING COMPLIANCE FORM
	STANDARD FORM 24 - BID BOND
	STANDARD FORM 28 - AFFIDAVIT OF INDIVIDUAL SURETY
	STANDARD FORM LLL - DISCLOSURE OF LOBBYING ACTIVITIES
00 11 00	PROPOSAL SUBMISSION REQUIREMENTS
00 12 00	SELECTION PROCEDURES AND BASIS OF AWARD
00 21 16	INSTRUCTIONS, CONDITIONS, & NOTICES TO OFFERORS
00 22 16	EVALUATION FACTORS FOR AWARD
00 45 00	REPRESENTATIONS, CERTIFICATION, & OTHER STATEMENTS
00 70 00	CONTRACT CLAUSES
00 73 00	SUPPLEMENTARY CONDITIONS
01 00 01	GENERAL CONTRACT REQUIREMENTS
	CESAM FORM 1151

SPECIFICATIONS

DIVISION 01 - GENERAL REQUIREMENTS

01 00 00	ADDITIONAL SPECIAL CONTRACT REQUIREMENTS
	EP310-1-6a PROJECT SIGNS
	DD FORM 1354
	DD FORM 1354 CHECKLIST
	WAGE RATES
01 14 00	WORK RESTRICTIONS
01 32 01.00 10	PROJECT SCHEDULE
01 33 00	SUBMITTAL PROCEDURES
	SUBMITTAL REGISTER
	ENG FORM 4025
01 33 29	SUSTAINABILITY REQUIREMENTS AND REPORTING
01 35 26	GOVERNMENTAL SAFETY REQUIREMENTS
01 42 00	SOURCES FOR REFERENCE PUBLICATIONS
01 45 00	QUALITY CONTROL
01 45 00.15 10	RESIDENT MANAGEMENT SYSTEM CONTRACTOR MODE (RMS CM)
	SAM FORM 696
01 45 35	SPECIAL INSPECTIONS
	ATTACHMENT A STATEMENT OF SPECIAL INSPECTIONS
	ATTACHMENT B SCHEDULE OF SPECIAL INSPECTIONS
	ATTACHMENT C CONTRACTOR'S STATEMENT OF RESPONSIBILITY
01 50 00	TEMPORARY CONSTRUCTION FACILITIES AND CONTROLS

DIVISION 01 - GENERAL REQUIREMENTS, CONTINUED

01 57 19 TEMPORARY ENVIRONMENTAL CONTROLS - EGLIN STANDARD
 ATTACHMENT A AF FORM 813 REQUEST FOR ENVIRONMENTAL
 IMPACT ANALYSIS
01 74 19 CONSTRUCTION WASTE MANAGEMENT AND DISPOSAL
01 78 00 CLOSEOUT SUBMITTALS
01 78 23 OPERATION AND MAINTENANCE DATA
01 91 00.15 10 BUILDING COMMISSIONING

DIVISION 03 - CONCRETE

03 30 00 CAST-IN-PLACE CONCRETE
03 54 13 GYPSUM CEMENT UNDERLAYMENT

DIVISION 04 - MASONRY

04 20 00 UNIT MASONRY

DIVISION 05 - METALS

05 05 20 POST-INSTALLED CONCRETE AND MASONRY ANCHORS
05 05 23.16 STRUCTURAL WELDING
05 30 00 STEEL DECKS
05 40 00 COLD-FORMED METAL FRAMING
05 44 00 PRE-ENGINEERED AND PRE-FABRICATED COLD-FORMED STEEL
 TRUSSES
05 50 13 MISCELLANEOUS METAL FABRICATIONS

DIVISION 06 - WOOD, PLASTICS, AND COMPOSITES

06 10 00 ROUGH CARPENTRY
06 12 13 SUBFLOOR PANEL
06 41 16.00 10 PLASTIC-LAMINATE-CLAD ARCHITECTURAL CABINETS
06 61 16 SOLID SURFACING FABRICATIONS

VOLUME 2 OF 4

DIVISION 07 - THERMAL AND MOISTURE PROTECTION

07 14 00 FLUID-APPLIED WATERPROOFING
07 21 16 MINERAL FIBER BLANKET INSULATION
07 22 00 ROOF AND DECK INSULATION
07 27 10 BUILDING AIR BARRIER SYSTEM
07 42 13 METAL WALL AND SOFFIT PANELS
07 60 00 FLASHING AND SHEET METAL
07 61 14.00 20 STEEL STANDING SEAM ROOFING
07 84 00 FIRESTOPPING
07 92 00 JOINT SEALANTS

DIVISION 08 - OPENINGS

08 11 13	STEEL DOORS AND FRAMES
08 31 00	ACCESS DOORS AND PANELS
08 34 01	FORCED ENTRY RESISTANT COMPONENTS
08 34 73	SOUND CONTROL DOOR ASSEMBLIES
08 51 23	STEEL WINDOWS
08 71 00	DOOR HARDWARE
08 81 00	GLAZING
08 91 00	METAL WALL LOUVERS
09 29 00	GYPSUM BOARD
09 30 10	CERAMIC, AND PORCELAIN TILING
09 62 38	STATIC-CONTROL FLOORING
09 65 00	RESILIENT FLOORING
09 67 23.14	CHEMICAL RESISTANT RESINOUS FLOORING
09 68 00	CARPETING
09 69 13	RIGID GRID ACCESS FLOORING
09 90 00	PAINTS AND COATINGS

DIVISION 10 - SPECIALTIES

10 11 00	VISUAL DISPLAY UNITS
10 14 00.10	EXTERIOR SIGNAGE
10 14 00.20	INTERIOR SIGNAGE
10 21 13	TOILET COMPARTMENTS
10 26 00	WALL AND DOOR PROTECTION
10 28 13	TOILET ACCESSORIES
10 44 16	FIRE EXTINGUISHERS
10 51 13	METAL LOCKERS

DIVISION 11 - EQUIPMENT

11 13 19.23	STATIONARY DOCK LIFT
-------------	----------------------

DIVISION 12 - FURNISHINGS

12 48 13	ENTRANCE FLOOR MATS
12 50 00.13 10	FURNITURE AND FURNITURE INSTALLATION
12 59 00	SYSTEMS FURNITURE

DIVISION 13 - SPECIAL CONSTRUCTION

13 49 20.00 10	RF SHIELDING
----------------	--------------

DIVISION 21 - FIRE SUPPRESSION

21 13 13	WET PIPE SPRINKLER SYSTEMS, FIRE PROTECTION
21 22 00	CLEAN AGENT FIRE EXTINGUISHING SYSTEM
21 30 10	FIRE PUMPS WITH DEDICATED ENCLOSURE

DIVISION 22 - PLUMBING

22 00 00	PLUMBING, GENERAL PURPOSE
----------	---------------------------

DIVISION 23 - HEATING, VENTILATING, AND AIR CONDITIONING (HVAC)

23 05 93 TESTING, ADJUSTING, AND BALANCING FOR HVAC
23 07 00 THERMAL INSULATION FOR MECHANICAL SYSTEMS
23 09 00 INSTRUMENTATION AND CONTROL FOR HVAC
23 09 13 INSTRUMENTATION AND CONTROL DEVICES FOR HVAC
23 09 23.02 BACNET DIRECT DIGITAL CONTROL FOR HVAC AND OTHER
BUILDING CONTROL SYSTEMS
23 23 00 REFRIGERANT PIPING
23 30 00 HVAC AIR DISTRIBUTION
23 81 00 DECENTRALIZED UNITARY HVAC EQUIPMENT
23 81 23 COMPUTER ROOM AIR CONDITIONING UNITS
23 83 00.00 20 ELECTRIC SPACE HEATING EQUIPMENT

VOLUME 3 OF 4

DIVISION 25 - INTEGRATED AUTOMATION

25 05 11.21 CYBERSECURITY FOR FACILITY-RELATED CONTROL SYSTEMS - FLS
25 05 11.25 CYBERSECURITY FOR FACILITY-RELATED CONTROL SYSTEMS - BCS
25 05 11.26 CYBERSECURITY FOR FACILITY-RELATED CONTROL SYSTEMS - UCS
25 05 11.28 CYBERSECURITY FOR FACILITY-RELATED CONTROL SYSTEMS - ESS
25 08 10 UTILITY MONITORING AND CONTROL SYSTEM TESTING
25 10 10 UTILITY MONITORING AND CONTROL SYSTEM (UMCS) FRONT END AND
INTEGRATION

DIVISION 26 - ELECTRICAL

26 05 73 POWER SYSTEM STUDIES
26 08 00 APPARATUS INSPECTION AND TESTING
26 20 00 INTERIOR DISTRIBUTION SYSTEM
26 27 13.10 30 ELECTRIC METERS
26 29 23 ADJUSTABLE SPEED DRIVE (ASD) SYSTEMS UNDER 600 VOLTS
26 32 15.00 ENGINE-GENERATOR SET STATIONARY 15-2500 KW, WITH
AUXILIARIES
26 33 53 STATIC UNINTERRUPTIBLE POWER SUPPLY (UPS)
26 36 23 AUTOMATIC TRANSFER SWITCHES AND BY-PASS/ISOLATION SWITCH
26 41 00 LIGHTNING PROTECTION SYSTEM
26 51 00 INTERIOR LIGHTING
26 56 00 EXTERIOR LIGHTING

DIVISION 27 - COMMUNICATIONS

27 10 00 BUILDING TELECOMMUNICATIONS CABLING SYSTEM

DIVISION 28 - ELECTRONIC SAFETY AND SECURITY

28 31 76 INTERIOR FIRE ALARM AND MASS NOTIFICATION SYSTEM,
ADDRESSABLE

DIVISION 31 - EARTHWORK

31 00 00 EARTHWORK

31 11 00 CLEARING AND GRUBBING

DIVISION 32 - EXTERIOR IMPROVEMENTS

32 01 19.61 SEALING OF JOINTS IN RIGID PAVEMENT
32 05 33 LANDSCAPE ESTABLISHMENT
32 11 23 AGGREGATE BASE COURS FOR FLEXIBLE PAVING
32 12 13 BITUMINOUS TACK AND PRIME COATS
32 12 16.16 ROAD-MIX ASPHALT PAVING
32 13 13.06 PORTLAND CEMENT CONCRETE PAVEMENT FOR ROADS AND SITE
FACILITIES
32 13 73.19 COMPRESSION CONCRETE PAVING JOINT SEALANT
32 16 19 CONCRETE CURBS, GUTTERS AND SIDEWALKS
32 17 23 PAVEMENT MARKINGS
32 92 19 SEEDING

DIVISION 33 - UTILITIES

33 01 50.31 LEAK DETECTION FOR FUELING SYSTEMS
33 11 00 WATER UTILITY DISTRIBUTION PIPING
33 30 00 SANITARY SEWERAGE
33 40 00 STORMWATER UTILITIES
33 71 02 UNDERGROUND ELECTRICAL DISTRIBUTION
33 82 00 TELECOMMUNICATIONS OUTSIDE PLANT (OSP)

VOLUME 4 OF 4

APPENDICES

APPENDIX A JUSTIFICATION AND APPROVAL (J&A) FOR CUMMINS DIESEL
GENERATOR
APPENDIX B JUSTIFICATION AND APPROVAL (J&A) FOR HEATING,
VENTILATION, AND AIR CONDITIONING (HVAC)
APPENDIX C JUSTIFICATION AND APPROVAL (J&A) FOR ONYX NOTIFIER FIRE
ALARM CONTROL PANEL (FACP)
APPENDIX D FURNITURE, FIXTURES, AND EQUIPMENT (FF&E)
APPENDIX E CONSTRUCTION SECURITY PLAN (CSP)

-- End of Project Table of Contents --

TABLE OF CONTENTS

VOLUME 1 OF 4

CHECKLIST FOR PREPARATION OF OFFERS
TABLE OF CONTENTS

CONTRACT CLAUSES

	STANDARD FORM 1442
	BIDDING SCHEDULE
	EXPLANATION OF BID ITEMS
	LIMITATIONS ON SUBCONTRACTING COMPLIANCE FORM
	STANDARD FORM 24 - BID BOND
	STANDARD FORM 28 - AFFIDAVIT OF INDIVIDUAL SURETY
	STANDARD FORM LLL - DISCLOSURE OF LOBBYING ACTIVITIES
00 11 00	PROPOSAL SUBMISSION REQUIREMENTS
00 12 00	SELECTION PROCEDURES AND BASIS OF AWARD
00 21 16	INSTRUCTIONS, CONDITIONS, & NOTICES TO OFFERORS
00 22 16	EVALUATION FACTORS FOR AWARD
00 45 00	REPRESENTATIONS, CERTIFICATION, & OTHER STATEMENTS
00 70 00	CONTRACT CLAUSES
00 73 00	SUPPLEMENTARY CONDITIONS
01 00 01	GENERAL CONTRACT REQUIREMENTS
	CESAM FORM 1151

SPECIFICATIONS

DIVISION 01 - GENERAL REQUIREMENTS

01 00 00	ADDITIONAL SPECIAL CONTRACT REQUIREMENTS
	EP310-1-6a PROJECT SIGNS
	DD FORM 1354
	DD FORM 1354 CHECKLIST
	WAGE RATES
01 14 00	WORK RESTRICTIONS
01 32 01.00 10	PROJECT SCHEDULE
01 33 00	SUBMITTAL PROCEDURES
	SUBMITTAL REGISTER
	ENG FORM 4025
01 33 29	SUSTAINABILITY REQUIREMENTS AND REPORTING
01 35 26	GOVERNMENTAL SAFETY REQUIREMENTS
01 42 00	SOURCES FOR REFERENCE PUBLICATIONS
01 45 00	QUALITY CONTROL
01 45 00.15 10	RESIDENT MANAGEMENT SYSTEM CONTRACTOR MODE (RMS CM)
	SAM FORM 696
01 45 35	SPECIAL INSPECTIONS
	ATTACHMENT A STATEMENT OF SPECIAL INSPECTIONS
	ATTACHMENT B SCHEDULE OF SPECIAL INSPECTIONS
	ATTACHMENT C CONTRACTOR'S STATEMENT OF RESPONSIBILITY
01 50 00	TEMPORARY CONSTRUCTION FACILITIES AND CONTROLS

DIVISION 01 - GENERAL REQUIREMENTS, CONTINUED

01 57 19 TEMPORARY ENVIRONMENTAL CONTROLS - EGLIN STANDARD
ATTACHMENT A AF FORM 813 REQUEST FOR ENVIRONMENTAL
IMPACT ANALYSIS
01 74 19 CONSTRUCTION WASTE MANAGEMENT AND DISPOSAL
01 78 00 CLOSEOUT SUBMITTALS
01 78 23 OPERATION AND MAINTENANCE DATA
01 91 00.15 10 BUILDING COMMISSIONING

DIVISION 03 - CONCRETE

03 30 00 CAST-IN-PLACE CONCRETE
03 54 13 GYPSUM CEMENT UNDERLAYMENT

DIVISION 04 - MASONRY

04 20 00 UNIT MASONRY

DIVISION 05 - METALS

05 05 20 POST-INSTALLED CONCRETE AND MASONRY ANCHORS
05 05 23.16 STRUCTURAL WELDING
05 30 00 STEEL DECKS
05 40 00 COLD-FORMED METAL FRAMING
05 44 00 PRE-ENGINEERED AND PRE-FABRICATED COLD-FORMED STEEL
TRUSSES
05 50 13 MISCELLANEOUS METAL FABRICATIONS

DIVISION 06 - WOOD, PLASTICS, AND COMPOSITES

06 10 00 ROUGH CARPENTRY
06 12 13 SUBFLOOR PANEL
06 41 16.00 10 PLASTIC-LAMINATE-CLAD ARCHITECTURAL CABINETS
06 61 16 SOLID SURFACING FABRICATIONS

VOLUME 2 OF 4

DIVISION 07 - THERMAL AND MOISTURE PROTECTION

07 14 00 FLUID-APPLIED WATERPROOFING
07 21 16 MINERAL FIBER BLANKET INSULATION
07 22 00 ROOF AND DECK INSULATION
07 27 10 BUILDING AIR BARRIER SYSTEM
07 42 13 METAL WALL AND SOFFIT PANELS
07 60 00 FLASHING AND SHEET METAL
07 61 14.00 20 STEEL STANDING SEAM ROOFING
07 84 00 FIRESTOPPING
07 92 00 JOINT SEALANTS

DIVISION 08 - OPENINGS

08 11 13	STEEL DOORS AND FRAMES
08 31 00	ACCESS DOORS AND PANELS
08 34 01	FORCED ENTRY RESISTANT COMPONENTS
08 34 73	SOUND CONTROL DOOR ASSEMBLIES
08 51 23	STEEL WINDOWS
08 71 00	DOOR HARDWARE
08 81 00	GLAZING
08 91 00	METAL WALL LOUVERS
09 29 00	GYPSUM BOARD
09 30 10	CERAMIC, AND PORCELAIN TILING
09 62 38	STATIC-CONTROL FLOORING
09 65 00	RESILIENT FLOORING
09 67 23.14	CHEMICAL RESISTANT RESINOUS FLOORING
09 68 00	CARPETING
09 69 13	RIGID GRID ACCESS FLOORING
09 90 00	PAINTS AND COATINGS

DIVISION 10 - SPECIALTIES

10 11 00	VISUAL DISPLAY UNITS
10 14 00.10	EXTERIOR SIGNAGE
10 14 00.20	INTERIOR SIGNAGE
10 21 13	TOILET COMPARTMENTS
10 26 00	WALL AND DOOR PROTECTION
10 28 13	TOILET ACCESSORIES
10 44 16	FIRE EXTINGUISHERS
10 51 13	METAL LOCKERS

DIVISION 11 - EQUIPMENT

11 13 19.23	STATIONARY DOCK LIFT
-------------	----------------------

DIVISION 12 - FURNISHINGS

12 48 13	ENTRANCE FLOOR MATS
12 50 00.13 10	FURNITURE AND FURNITURE INSTALLATION
12 59 00	SYSTEMS FURNITURE

DIVISION 13 - SPECIAL CONSTRUCTION

13 49 20.00 10	RF SHIELDING
----------------	--------------

DIVISION 21 - FIRE SUPPRESSION

21 13 13	WET PIPE SPRINKLER SYSTEMS, FIRE PROTECTION
21 22 00	CLEAN AGENT FIRE EXTINGUISHING SYSTEM
21 30 10	FIRE PUMPS WITH DEDICATED ENCLOSURE

DIVISION 22 - PLUMBING

22 00 00	PLUMBING, GENERAL PURPOSE
----------	---------------------------

DIVISION 23 - HEATING, VENTILATING, AND AIR CONDITIONING (HVAC)

23 05 93 TESTING, ADJUSTING, AND BALANCING FOR HVAC
23 07 00 THERMAL INSULATION FOR MECHANICAL SYSTEMS
23 09 00 INSTRUMENTATION AND CONTROL FOR HVAC
23 09 13 INSTRUMENTATION AND CONTROL DEVICES FOR HVAC
23 09 23.02 BACNET DIRECT DIGITAL CONTROL FOR HVAC AND OTHER
BUILDING CONTROL SYSTEMS
23 23 00 REFRIGERANT PIPING
23 30 00 HVAC AIR DISTRIBUTION
23 81 00 DECENTRALIZED UNITARY HVAC EQUIPMENT
23 81 23 COMPUTER ROOM AIR CONDITIONING UNITS
23 83 00.00 20 ELECTRIC SPACE HEATING EQUIPMENT

VOLUME 3 OF 4

DIVISION 25 - INTEGRATED AUTOMATION

25 05 11.21 CYBERSECURITY FOR FACILITY-RELATED CONTROL SYSTEMS - FLS
25 05 11.25 CYBERSECURITY FOR FACILITY-RELATED CONTROL SYSTEMS - BCS
25 05 11.26 CYBERSECURITY FOR FACILITY-RELATED CONTROL SYSTEMS - UCS
25 05 11.28 CYBERSECURITY FOR FACILITY-RELATED CONTROL SYSTEMS - ESS
25 08 10 UTILITY MONITORING AND CONTROL SYSTEM TESTING
25 10 10 UTILITY MONITORING AND CONTROL SYSTEM (UMCS) FRONT END AND
INTEGRATION

DIVISION 26 - ELECTRICAL

26 05 73 POWER SYSTEM STUDIES
26 08 00 APPARATUS INSPECTION AND TESTING
26 20 00 INTERIOR DISTRIBUTION SYSTEM
26 27 13.10 30 ELECTRIC METERS
26 29 23 ADJUSTABLE SPEED DRIVE (ASD) SYSTEMS UNDER 600 VOLTS
26 32 15.00 ENGINE-GENERATOR SET STATIONARY 15-2500 KW, WITH
AUXILIARIES
26 33 53 STATIC UNINTERRUPTIBLE POWER SUPPLY (UPS)
26 36 23 AUTOMATIC TRANSFER SWITCHES AND BY-PASS/ISOLATION SWITCH
26 41 00 LIGHTNING PROTECTION SYSTEM
26 51 00 INTERIOR LIGHTING
26 56 00 EXTERIOR LIGHTING

DIVISION 27 - COMMUNICATIONS

27 10 00 BUILDING TELECOMMUNICATIONS CABLING SYSTEM

DIVISION 28 - ELECTRONIC SAFETY AND SECURITY

28 31 76 INTERIOR FIRE ALARM AND MASS NOTIFICATION SYSTEM,
ADDRESSABLE

DIVISION 31 - EARTHWORK

31 00 00 EARTHWORK

31 11 00 CLEARING AND GRUBBING

DIVISION 32 - EXTERIOR IMPROVEMENTS

32 01 19.61 SEALING OF JOINTS IN RIGID PAVEMENT
32 05 33 LANDSCAPE ESTABLISHMENT
32 11 23 AGGREGATE BASE COURS FOR FLEXIBLE PAVING
32 12 13 BITUMINOUS TACK AND PRIME COATS
32 12 16.16 ROAD-MIX ASPHALT PAVING
32 13 13.06 PORTLAND CEMENT CONCRETE PAVEMENT FOR ROADS AND SITE
FACILITIES
32 13 73.19 COMPRESSION CONCRETE PAVING JOINT SEALANT
32 16 19 CONCRETE CURBS, GUTTERS AND SIDEWALKS
32 17 23 PAVEMENT MARKINGS
32 92 19 SEEDING

DIVISION 33 - UTILITIES

33 01 50.31 LEAK DETECTION FOR FUELING SYSTEMS
33 11 00 WATER UTILITY DISTRIBUTION PIPING
33 30 00 SANITARY SEWERAGE
33 40 00 STORMWATER UTILITIES
33 71 02 UNDERGROUND ELECTRICAL DISTRIBUTION
33 82 00 TELECOMMUNICATIONS OUTSIDE PLANT (OSP)

VOLUME 4 OF 4

APPENDICES

APPENDIX A JUSTIFICATION AND APPROVAL (J&A) FOR CUMMINS DIESEL
GENERATOR
APPENDIX B JUSTIFICATION AND APPROVAL (J&A) FOR HEATING,
VENTILATION, AND AIR CONDITIONING (HVAC)
APPENDIX C JUSTIFICATION AND APPROVAL (J&A) FOR ONYX NOTIFIER FIRE
ALARM CONTROL PANEL (FACP)
APPENDIX D FURNITURE, FIXTURES, AND EQUIPMENT (FF&E)
APPENDIX E CONSTRUCTION SECURITY PLAN (CSP)

-- End of Project Table of Contents --

TABLE OF CONTENTS

VOLUME 1 OF 4

CHECKLIST FOR PREPARATION OF OFFERS
TABLE OF CONTENTS

CONTRACT CLAUSES

	STANDARD FORM 1442
	BIDDING SCHEDULE
	EXPLANATION OF BID ITEMS
	LIMITATIONS ON SUBCONTRACTING COMPLIANCE FORM
	STANDARD FORM 24 - BID BOND
	STANDARD FORM 28 - AFFIDAVIT OF INDIVIDUAL SURETY
	STANDARD FORM LLL - DISCLOSURE OF LOBBYING ACTIVITIES
00 11 00	PROPOSAL SUBMISSION REQUIREMENTS
00 12 00	SELECTION PROCEDURES AND BASIS OF AWARD
00 21 16	INSTRUCTIONS, CONDITIONS, & NOTICES TO OFFERORS
00 22 16	EVALUATION FACTORS FOR AWARD
00 45 00	REPRESENTATIONS, CERTIFICATION, & OTHER STATEMENTS
00 70 00	CONTRACT CLAUSES
00 73 00	SUPPLEMENTARY CONDITIONS
01 00 01	GENERAL CONTRACT REQUIREMENTS
	CESAM FORM 1151

SPECIFICATIONS

DIVISION 01 - GENERAL REQUIREMENTS

01 00 00	ADDITIONAL SPECIAL CONTRACT REQUIREMENTS
	EP310-1-6a PROJECT SIGNS
	DD FORM 1354
	DD FORM 1354 CHECKLIST
	WAGE RATES
01 14 00	WORK RESTRICTIONS
01 32 01.00 10	PROJECT SCHEDULE
01 33 00	SUBMITTAL PROCEDURES
	SUBMITTAL REGISTER
	ENG FORM 4025
01 33 29	SUSTAINABILITY REQUIREMENTS AND REPORTING
01 35 26	GOVERNMENTAL SAFETY REQUIREMENTS
01 42 00	SOURCES FOR REFERENCE PUBLICATIONS
01 45 00	QUALITY CONTROL
01 45 00.15 10	RESIDENT MANAGEMENT SYSTEM CONTRACTOR MODE (RMS CM)
	SAM FORM 696
01 45 35	SPECIAL INSPECTIONS
	ATTACHMENT A STATEMENT OF SPECIAL INSPECTIONS
	ATTACHMENT B SCHEDULE OF SPECIAL INSPECTIONS
	ATTACHMENT C CONTRACTOR'S STATEMENT OF RESPONSIBILITY
01 50 00	TEMPORARY CONSTRUCTION FACILITIES AND CONTROLS

DIVISION 01 - GENERAL REQUIREMENTS, CONTINUED

01 57 19 TEMPORARY ENVIRONMENTAL CONTROLS - EGLIN STANDARD
ATTACHMENT A AF FORM 813 REQUEST FOR ENVIRONMENTAL
IMPACT ANALYSIS
01 74 19 CONSTRUCTION WASTE MANAGEMENT AND DISPOSAL
01 78 00 CLOSEOUT SUBMITTALS
01 78 23 OPERATION AND MAINTENANCE DATA
01 91 00.15 10 BUILDING COMMISSIONING

DIVISION 03 - CONCRETE

03 30 00 CAST-IN-PLACE CONCRETE
03 54 13 GYPSUM CEMENT UNDERLAYMENT

DIVISION 04 - MASONRY

04 20 00 UNIT MASONRY

DIVISION 05 - METALS

05 05 20 POST-INSTALLED CONCRETE AND MASONRY ANCHORS
05 05 23.16 STRUCTURAL WELDING
05 30 00 STEEL DECKS
05 40 00 COLD-FORMED METAL FRAMING
05 44 00 PRE-ENGINEERED AND PRE-FABRICATED COLD-FORMED STEEL
TRUSSES
05 50 13 MISCELLANEOUS METAL FABRICATIONS

DIVISION 06 - WOOD, PLASTICS, AND COMPOSITES

06 10 00 ROUGH CARPENTRY
06 12 13 SUBFLOOR PANEL
06 41 16.00 10 PLASTIC-LAMINATE-CLAD ARCHITECTURAL CABINETS
06 61 16 SOLID SURFACING FABRICATIONS

VOLUME 2 OF 4

DIVISION 07 - THERMAL AND MOISTURE PROTECTION

07 14 00 FLUID-APPLIED WATERPROOFING
07 21 16 MINERAL FIBER BLANKET INSULATION
07 22 00 ROOF AND DECK INSULATION
07 27 10 BUILDING AIR BARRIER SYSTEM
07 42 13 METAL WALL AND SOFFIT PANELS
07 60 00 FLASHING AND SHEET METAL
07 61 14.00 20 STEEL STANDING SEAM ROOFING
07 84 00 FIRESTOPPING
07 92 00 JOINT SEALANTS

DIVISION 08 - OPENINGS

08 11 13	STEEL DOORS AND FRAMES
08 31 00	ACCESS DOORS AND PANELS
08 34 01	FORCED ENTRY RESISTANT COMPONENTS
08 34 73	SOUND CONTROL DOOR ASSEMBLIES
08 51 23	STEEL WINDOWS
08 71 00	DOOR HARDWARE
08 81 00	GLAZING
08 91 00	METAL WALL LOUVERS
09 29 00	GYPSUM BOARD
09 30 10	CERAMIC, AND PORCELAIN TILING
09 62 38	STATIC-CONTROL FLOORING
09 65 00	RESILIENT FLOORING
09 67 23.14	CHEMICAL RESISTANT RESINOUS FLOORING
09 68 00	CARPETING
09 69 13	RIGID GRID ACCESS FLOORING
09 90 00	PAINTS AND COATINGS

DIVISION 10 - SPECIALTIES

10 11 00	VISUAL DISPLAY UNITS
10 14 00.10	EXTERIOR SIGNAGE
10 14 00.20	INTERIOR SIGNAGE
10 21 13	TOILET COMPARTMENTS
10 26 00	WALL AND DOOR PROTECTION
10 28 13	TOILET ACCESSORIES
10 44 16	FIRE EXTINGUISHERS
10 51 13	METAL LOCKERS

DIVISION 11 - EQUIPMENT

11 13 19.23	STATIONARY DOCK LIFT
-------------	----------------------

DIVISION 12 - FURNISHINGS

12 48 13	ENTRANCE FLOOR MATS
12 50 00.13 10	FURNITURE AND FURNITURE INSTALLATION
12 59 00	SYSTEMS FURNITURE

DIVISION 13 - SPECIAL CONSTRUCTION

13 49 20.00 10	RF SHIELDING
----------------	--------------

DIVISION 21 - FIRE SUPPRESSION

21 13 13	WET PIPE SPRINKLER SYSTEMS, FIRE PROTECTION
21 22 00	CLEAN AGENT FIRE EXTINGUISHING SYSTEM
21 30 10	FIRE PUMPS WITH DEDICATED ENCLOSURE

DIVISION 22 - PLUMBING

22 00 00	PLUMBING, GENERAL PURPOSE
----------	---------------------------

DIVISION 23 - HEATING, VENTILATING, AND AIR CONDITIONING (HVAC)

23 05 93 TESTING, ADJUSTING, AND BALANCING FOR HVAC
23 07 00 THERMAL INSULATION FOR MECHANICAL SYSTEMS
23 09 00 INSTRUMENTATION AND CONTROL FOR HVAC
23 09 13 INSTRUMENTATION AND CONTROL DEVICES FOR HVAC
23 09 23.02 BACNET DIRECT DIGITAL CONTROL FOR HVAC AND OTHER
BUILDING CONTROL SYSTEMS
23 23 00 REFRIGERANT PIPING
23 30 00 HVAC AIR DISTRIBUTION
23 81 00 DECENTRALIZED UNITARY HVAC EQUIPMENT
23 81 23 COMPUTER ROOM AIR CONDITIONING UNITS
23 83 00.00 20 ELECTRIC SPACE HEATING EQUIPMENT

VOLUME 3 OF 4

DIVISION 25 - INTEGRATED AUTOMATION

25 05 11.21 CYBERSECURITY FOR FACILITY-RELATED CONTROL SYSTEMS - FLS
25 05 11.25 CYBERSECURITY FOR FACILITY-RELATED CONTROL SYSTEMS - BCS
25 05 11.26 CYBERSECURITY FOR FACILITY-RELATED CONTROL SYSTEMS - UCS
25 05 11.28 CYBERSECURITY FOR FACILITY-RELATED CONTROL SYSTEMS - ESS
25 08 10 UTILITY MONITORING AND CONTROL SYSTEM TESTING
25 10 10 UTILITY MONITORING AND CONTROL SYSTEM (UMCS) FRONT END AND
INTEGRATION

DIVISION 26 - ELECTRICAL

26 05 73 POWER SYSTEM STUDIES
26 08 00 APPARATUS INSPECTION AND TESTING
26 20 00 INTERIOR DISTRIBUTION SYSTEM
26 27 13.10 30 ELECTRIC METERS
26 29 23 ADJUSTABLE SPEED DRIVE (ASD) SYSTEMS UNDER 600 VOLTS
26 32 15.00 ENGINE-GENERATOR SET STATIONARY 15-2500 KW, WITH
AUXILIARIES
26 33 53 STATIC UNINTERRUPTIBLE POWER SUPPLY (UPS)
26 36 23 AUTOMATIC TRANSFER SWITCHES AND BY-PASS/ISOLATION SWITCH
26 41 00 LIGHTNING PROTECTION SYSTEM
26 51 00 INTERIOR LIGHTING
26 56 00 EXTERIOR LIGHTING

DIVISION 27 - COMMUNICATIONS

27 10 00 BUILDING TELECOMMUNICATIONS CABLING SYSTEM

DIVISION 28 - ELECTRONIC SAFETY AND SECURITY

28 31 76 INTERIOR FIRE ALARM AND MASS NOTIFICATION SYSTEM,
ADDRESSABLE

DIVISION 31 - EARTHWORK

31 00 00 EARTHWORK

31 11 00 CLEARING AND GRUBBING

DIVISION 32 - EXTERIOR IMPROVEMENTS

32 01 19.61 SEALING OF JOINTS IN RIGID PAVEMENT
32 05 33 LANDSCAPE ESTABLISHMENT
32 11 23 AGGREGATE BASE COURS FOR FLEXIBLE PAVING
32 12 13 BITUMINOUS TACK AND PRIME COATS
32 12 16.16 ROAD-MIX ASPHALT PAVING
32 13 13.06 PORTLAND CEMENT CONCRETE PAVEMENT FOR ROADS AND SITE
FACILITIES
32 13 73.19 COMPRESSION CONCRETE PAVING JOINT SEALANT
32 16 19 CONCRETE CURBS, GUTTERS AND SIDEWALKS
32 17 23 PAVEMENT MARKINGS
32 92 19 SEEDING

DIVISION 33 - UTILITIES

33 01 50.31 LEAK DETECTION FOR FUELING SYSTEMS
33 11 00 WATER UTILITY DISTRIBUTION PIPING
33 30 00 SANITARY SEWERAGE
33 40 00 STORMWATER UTILITIES
33 71 02 UNDERGROUND ELECTRICAL DISTRIBUTION
33 82 00 TELECOMMUNICATIONS OUTSIDE PLANT (OSP)

VOLUME 4 OF 4

APPENDICES

APPENDIX A JUSTIFICATION AND APPROVAL (J&A) FOR CUMMINS DIESEL
GENERATOR
APPENDIX B JUSTIFICATION AND APPROVAL (J&A) FOR HEATING,
VENTILATION, AND AIR CONDITIONING (HVAC)
APPENDIX C JUSTIFICATION AND APPROVAL (J&A) FOR ONYX NOTIFIER FIRE
ALARM CONTROL PANEL (FACP)
APPENDIX D FURNITURE, FIXTURES, AND EQUIPMENT (FF&E)
APPENDIX E CONSTRUCTION SECURITY PLAN (CSP)

-- End of Project Table of Contents --

APPENDIX D
FURNITURE, FIXTURES, AND EQUIPMENT
(FF&E)

NOTE

The information included in this appendix is provided solely as a basis for design. None of the items included in this section are to be considered a Brand Name requirements and/or Brand Name or Equal requirement.

O. Furniture FF&E Procurement Data Sheets

Products indicated in this Request for Quote (RFQ) are the approved basis of design to convey general style and required performance. The identification of specific products is not intended to limit the consideration and selection of products provided by other manufacturers. Products meeting these salient characteristics and performance criteria will be considered and reviewed by the Interior Designer of Record (IDOR), the Base Interior Designer and approved by the Contracting Officer.

FF&E Procurement Information

Item Description: TASK CHAIR, GENERAL

Item Code: C1a

Item Picture:

Manufacturer: STEELCASE

Design Series: N/A

Dimensions: 24 3/4"D x 26 5/8"W x 42 1/2"H

Warranty: LIMITED LIFETIME

Salient Characteristics

3D MICROKNIT ON PLASTIC AIR BACK W/
 INTEGRATED AIR LIVE BACK TECHNOLOGY,
 SYNCHRO TILT MECHANISM, WEIGHT LIMIT
 400LBS, STANDARD 5" PNEUMATIC SEAT HEIGHT
 RANGE, UPRIGHT BACK LOCK, 4D ADJUSTABLE
 ARMS, RECTILINEAR ARMS W/ SOFT CAPS, 3"
 SEAT DEPTH ADJUSTMENT, PASSIVE SEAT EDGE
 ANGLE, HEIGHT ADJUSTABLE LUMBAR, HARD
 CASTERS FOR CARPETED FLOOR



Note - Finishes pictured may vary from item specified

Finish Images



Plastic Outer Back Frame, Arm, Holsters & Base
 Black Plastic 6205
 Plastic Inner Back Frame and Lumbar, Outer Seat Shell
 Black Plastic 6205
 Plastic Air Back Near Black 6295
 3D Micro Knit Back Nickel 5T20
 Seat Upholstery Gr. 3 Design Tex Overtone Soft Grey 3056-803

Location and Quantity

SECURITY 132: 4
 COLLATERAL 104: 6
 OPEN OFFICE 111: 15
 OPEN OFFICE 129: 9

Total Quantity: 34

Finish

Plastic Air Back: Steelcase, Near Black 6295
 Mesh Back: Steelcase, 3D Microknit, Classics Collection, Nickel 5T20
 Seat: DesignTex, Overtone, Soft Grey 3056-803
 Frame/Base: Steelcase Plastic, Black 6205

GSA/BPA Contract: See Manufacturer's Source List for Manufacturer Contact Information

Sustainability:

CHAIR: CARBON NEUTRAL
 DESIGNTEX FABRIC: SHIPS CARBON NEUTRAL, HHI COMPLIANT, HPD, LBC RED LIST COMPLIANT, LEED, MINDFUL MATERIALS, NO PROP 65 CHEMICALS, WELL, NO ANTIMICROBIALS, NO FLAME RETARDANTS, NO PFAS

FF&E Procurement Information

Item Description: TASK CHAIR, PRIVATE OFFICE

Item Code: C1b **Item Picture:**

Manufacturer: STEELCASE
Design Series: N/A

Dimensions: 24 3/4"D x 26 5/8"W x 42 1/2"H
Warranty: LIMITED LIFETIME

Salient Characteristics

3D MICROKNIT ON PLASTIC AIR BACK W/
 INTEGRATED AIR LIVE BACK TECHNOLOGY,
 SYNCHRO TILT MECHANISM, WEIGHT LIMIT
 400LBS, STANDARD 5" PNEUMATIC SEAT HEIGHT
 RANGE, UPRIGHT BACK LOCK, 4D ADJUSTABLE
 ARMS, RECTILINEAR ARMS W/ SOFT CAPS, 3"
 SEAT DEPTH ADJUSTMENT, PASSIVE SEAT EDGE
 ANGLE, HEIGHT ADJUSTABLE LUMBAR, HARD
 CASTERS FOR CARPETED FLOOR



Note - Finishes pictured may vary from item specified

Finish Images

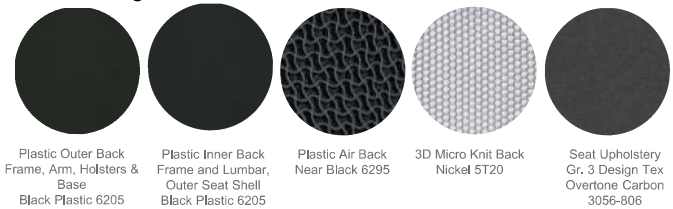

Location and Quantity

OFFICE 112: 1
 OFFICE 113: 1
 OFFICE 130: 1

Total Quantity: 3

Finish

Plastic Air Back: Steelcase, Near Black 6295
 Mesh Back: Steelcase, 3D Microknit, Classics Collection, Nickel 5T20
 Seat: DesignTex, Overtone Carbon 3056-806
 Frame/Base: Steelcase Plastic, Merle 6527

GSA/BPA Contract: See Manufacturer's Source List for Manufacturer Contact Information

Sustainability:

CHAIR: CARBON NEUTRAL
 DESIGNTEX FABRIC: GREENGUARD GOLD, HPD, MINDFUL MATERIALS, NO PROP 65 CHEMICALS, WELL, NO
 ANTIMICROBIALS, NO FLAME REATARDANTS, NO PFAS, SHIPS CARBON NEUTRAL

FF&E Procurement Information

Item Description: TASK CHAIR, LAB CONTROL #1 & #2

Item Code: C1c **Item Picture:**

Manufacturer: STEELCASE
Design Series: N/A

Dimensions: 24 3/4"D x 26 5/8"W x 42 1/2"H
Warranty: LIMITED LIFETIME

Salient Characteristics

PLASTIC AIR BACK W/ INTEGRATED AIR LIVE BACK TECHNOLOGY, SYNCHRO TILT MECHANISM, WEIGHT LIMIT 400LBS, 5" PNEUMATIC SEAT HEIGHT RANGE, UPRIGHT BACK LOCK, 4D ADJUSTABLE ARMS, RECTILINEAR ARMS W/ SOFT CAPS, 3" SEAT DEPTH ADJUSTMENT, PASSIVE SEAT EDGE ANGLE, HEIGHT ADJUSTABLE LUMBAR, SOFT CASTERS FOR HARD FLOOR.



Finish Images

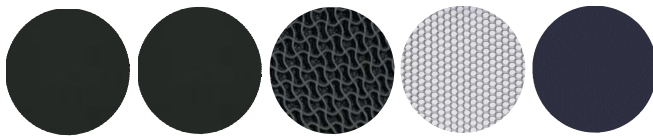

Plastic Outer Back Frame, Arm, Holsters & Base
Black Plastic 6205
 Plastic Inner Back Frame and Lumbar, Outer Seat Shell
Black Plastic 6205
 Plastic Air Back Near Black 6295
 3D Micro Knit Back Nickel 5T20
 Seat Upholstery Gr. 5 – Designtex Tour Bewilder 3072-407

Note - Finishes pictured may vary from item specified

Location and Quantity

LAB #1 CONTROL: 6
 LAB #2 CONTROL: 6

Total Quantity: 12

Finish

Back: steelcase, Plastic Air Back, Near Black 6295
 Seat: Designtex Vinyl, Tour, Bewilder 3072-407
 Frame/Base: Black Plastic 6205

GSA/BPA Contract: See Manufacturer's Source List for Manufacturer Contact Information

Sustainability:

CHAIR: CARBON NEUTRAL
 DESIGNTEX FABRIC: GREENGUARD GOLD, HPD, MINDFUL MATERIALS, NO PROP 65 CHEMICALS, WELL, NO ANTIMICROBIALS, NO FLAME REATARDANTS, NO PFAS, SHIPS CARBON NEUTRAL

FF&E Procurement Information

Item Description: SIDE CHAIR, CONFERENCE

Item Code: C3a

Item Picture:

Manufacturer: SIT ON IT
Design Series: N/A



Dimensions: 23"D x 23"W x 35"H; SEAT HEIGHT

Warranty: LIMITED LIFETIME

Salient Characteristics

ARMS, UPHOLSTERED SEAT, MESH BACK, NESTING; 300LBS WEIGHT CAPACITY WARRANTY; CARPET CASTERS

Finish Images

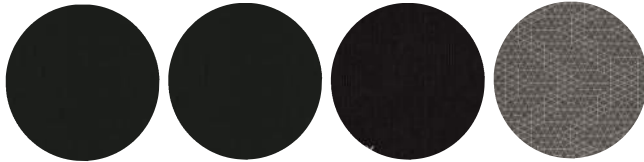

Back Frame & Arm Color
Black SC1

Base & Caster Finish
Black FC1

Back Mesh
Onyx MC20

Seat Upholstery
SOI Gr. 9 Design Tex
Net Print
3869-803

Note - Finishes pictured may vary from item specified

Location and Quantity

LARGE CONFERENCE 131: 5

Total Quantity: 5

Finish

Back: Sit-On-It, Mesh Back Onyx MC20
 Seat: Designtex Woven, Net, Print 3869-803
 Frame/Arm: Sit-On-It, Black SC1
 Base: Black FC1

GSA/BPA Contract: See Manufacturer's Source List for Manufacturer Contact Information

Sustainability:

CHAIR: BIFMA LEVEL 2, CONTAINS RECYCLED CONTENT, GREENGUARD GOLD, PROP 65 CHEMICAL FREE
 DESIGNTEX FABRIC: GREENGUARD GOLD, HHI, LEED, MINDFUL MATERIALS, NO PROP 65 CHEMICALS, WELL, LOW VOC, NO ANTIMICROBIALS, NO FLAME RETARDANTS, NO PFAS, SHIPS CARBON NEUTRAL

FF&E Procurement Information

Item Description: SIDE CHAIR, BREAK ROOM

Item Code: C3b

Item Picture:

Manufacturer: SIT ON IT

Design Series: N/A

Dimensions: 24"W x 22"D x 33"H; SEAT 19"H

Warranty: LIMITED LIFETIME

Salient Characteristics

ARMS, PLASTIC ARM CAP, PLASTIC SEAT, PLASTIC BACK, WALL-SAVER LEGS; NON-MARRING FLOOR GLIDES; PAINTED METAL FRAME



Finish Images

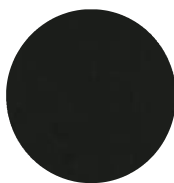

Back Frame Black
FC1



Plastic Shell
Navy SC5

Note - Finishes pictured may vary from item specified

Location and Quantity

BREAK ROOM 103: 2

Total Quantity: 2

Finish

Seat: Sit on It, Plastic Shell, Navy SC5Back: Sit on It Plastic Shell, Navy SC5Frame: Black FC1

GSA/BPA Contract: See Manufacturer's Source List for Manufacturer Contact Information

Sustainability:

CHAIR: BIFMA LEVEL 2, GREENGUARD GOLD, CONTAINS RECYCLED CONTENT, PROP 65 CHEMICAL FREE

FF&E Procurement Information

Item Description: SIDE CHAIR, GENERAL

Item Code: C3c

Item Picture:

Manufacturer: SIT ON IT
Design Series: N/A



Dimensions: 23"D x 23"W x 35"H; SEAT 18"H
Warranty: LIMITED LIFETIME

Salient Characteristics

ARMS, MESH BACK, UPHOLSTERED SEAT,
 MOVABLE W/ CASTER, NESTING
 FULLY ASSEMBLED IN CARTON

Finish Images

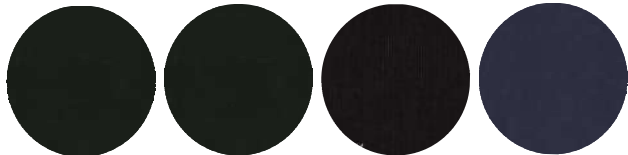

Back Frame & Arm Color Black SC1
 Base & Caster Finish Black FC1
 Back Mesh Onyx MC20
 Seat Upholstery - Vinyl SOI Gr. 5 - Design Tex Tour Bewilder 3072-407

Note - Finishes pictured may vary from item specified

Location and Quantity

OFFICE 112: 2
 OFFICE 113: 2
 OFFICE 130: 2

Total Quantity: 6

Finish

Frame/Arm: Black SC1
 Base: Black FC1
 Back: Sit On It, Mesh, Onyx MC20
 Seat: Designtex, Tour, Bewilder 3072-407

GSA/BPA Contract: See Manufacturer's Source List for Manufacturer Contact Information

Sustainability:

CHAIR: BIFMA LEVEL 2, CONTAINS RECYCLED CONTENT, GREENGUARD GOLD, PROP 65 CHEMICAL FREE
 DESIGNTEX FABRIC: GREENGUARD GOLD, HPD, MINDFUL MATERIALS, NO PROP 65 CHEMICALS, WELL, NO
 ANTIMICROBIALS, NO FLAME REATARDANTS, NO PFAS, SHIPS CARBON NEUTRAL

FF&E Procurement Information

Item Description: LOUNGE CHAIR

Item Code: C3d

Item Picture:

Manufacturer: STEELCASE

Dimensions: 25.25"D x 27.25"W x 29.75"H

Warranty: LIMITED LIFETIME

Salient Characteristics

UPHOLSTERED FRONT AND BACK, UPHOLSTERED SEAT, SWIVEL



Finish Images

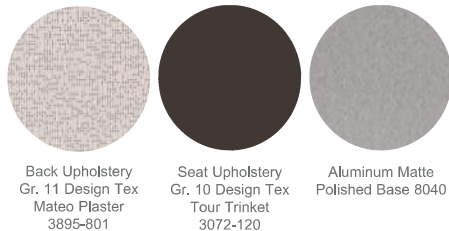

Back Upholstery
 Gr. 11 Design Tex
 Mateo Plaster
 3895-801

Seat Upholstery
 Gr. 10 Design Tex
 Tour Trinket
 3072-120

Aluminum Matte
 Polished Base 8040

Note - Finishes pictured may vary from item specified

Location and Quantity

MOTHER'S ROOM 108: 1

Total Quantity: 1

Finish

Base: Aluminum Matte Polished Base 8040
 Upholstered Front/Back: Designtex Mateo, Plaster 3895-801
 Upholstered Seat: Designtex, Tour Trinket 3072-120

GSA/BPA Contract: See Manufacturer's Source List for Manufacturer Contact Information

Sustainability:

CHAIR: BIFMA LEVEL 2, SCS INDOOR ADVANTAGE GOLD
 DESIGNTEX MATEO FABRIC: HHI, HPD, LBC RED LIST COMPLIANT, LEED, MINDFUL MATERIALS, NO PROP 65 CHEMICALS, WELL, LOW VOC, NO ANTIMICROBIALS, NO FLAME RETARDANTS, NO PFAS, SHIPS CARBON NEURAL
 DESIGNTEXT TOUR FABRIC: GREENGUARD GOLD, HPD, MINDFUL MATERIALS, NO PROP 65 CHEMICALS, WELL, NO ANTIMICROBIALS, NO FLAME RETARDANTS, NO PFAS, SHIPS CARBON NEURAL

FF&E Procurement Information

Item Description: CONFERENCE CHAIR

Item Code: C4

Item Picture:

Manufacturer: STEELCASE
Design Series: N/A



Dimensions: 24 3/4"D x 26 5/8"W x 42 1/2"H
Warranty: LIMITED LIFETIME

Salient Characteristics

UPHOLSTERED BACK, SEWN, CONTRASTING FABRIC; SYNCHRO TILT MECHANISM, STANDARD 5" SEAT HEIGHT RANGE; UPRIGHT BACK LOCK; 4D ADJUSTABLE ARMS; RECTILINEAR ARMS W/ SOFT CAPS; 3" SEAT DEPTH ADJUSTMENT; PASSIVE SEAT EDGE ANGLE; HEIGHT ADJUSTABLE LUMBAR; HARD CASTERS FOR CARPETED FLOOR

Finish Images

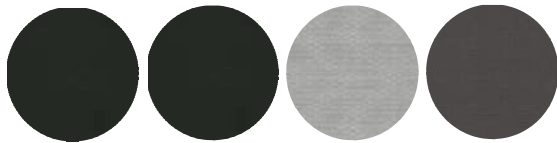

Plastic Outer Back Frame, Arm & Holsters Black Plastic 6205
 Plastic Inner Back Frame and Lumbar, Outer Seat Shell Black Plastic 6205
 Back Upholstery Gr. 7 Design Tex Net Solstice 3869-801
 Seat Upholstery Gr. 4 Design Tex Aspect Ore 3887-105

Note - Finishes pictured may vary from item specified

Location and Quantity

LARGE CONFERENCE 131: 12

Total Quantity: 12

Finish

Back: Designtex Woven, Net Solstice 3869-801
 Seat: Designtex Vinyl, Aspect Ore 3887-105
 Frame: Steelcase, Black Plastic 6205
 Base: Steelcase, Polished Aluminum

GSA/BPA Contract: See Manufacturer's Source List for Manufacturer Contact Information

Sustainability:

CHAIR: CARBON NEUTRAL
 DESIGNTEX FABRIC: GREENGUARD GOLD, HPD, MINDFUL MATERIALS, NO PROP 65 CHEMICALS, WELL, NO ANTIMICROBIALS, NO FLAME REATARDANTS, NO PFAS, SHIPS CARBON NEUTRAL

FF&E Procurement Information

Item Description: WALL CLOCK, ANALOG

Item Code: CL1

Item Picture:

Manufacturer: SKILCRAFT

Design Series: N/A

Dimensions: 12.75" DIA

Warranty: 1 YEAR LIMITED

Salient Characteristics

ANALOG CLOCK; LOW-PROFILE BODY; SELF-SETTING FOR DAYLIGHT SAVINGS; BATTERY-OPERATED



Finish Images

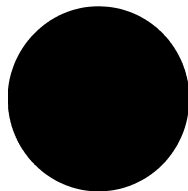

Color
Black

Note - Finishes pictured may vary from item specified

Location and Quantity

SECURITY 132: 1	OFFICE 112, 113 130: 3
LARGE CONFERENCE: 1	OPEN OFFICE 111 & 129: 2
COLLATERAL 104: 1	LAB CONTROL #1 & #2: 2
BREAK ROOM 103: 1	
MOTHER'S ROOM 108: 1	

Total Quantity: 12

Finish

Frame: Black

GSA/BPA Contract: See Manufacturer's Source List for Manufacturer Contact Information

Sustainability:

30% POST-CONSUMER RECYCLED MATERIALS; BIODEGRADABLE

FF&E Procurement Information

Item Description: FOOT STOOL, UPHOLSTERED

Item Code: FS1

Item Picture:

Manufacturer: STEELCASE

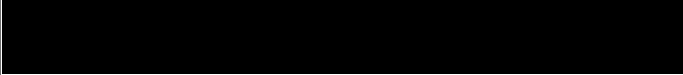

Dimensions: 18.5"D x 19.75"W x 15.25"H

Warranty: LIMITED LIFETIME

Salient Characteristics

UPHOLSTERED FOOTSTOOL



Finish Images



Back Upholstery
 Gr. 11 Design Tex
 Mateo Plaster
 3895-801



Seat Upholstery
 Gr. 10 Design Tex
 Tour Trinket
 3072-120



Aluminum Matte
 Polished Base 8040

Note - Finishes pictured may vary from item specified

Location and Quantity

MOTHER'S ROOM 108: 1

Total Quantity: 1

Finish

Base: Aluminum Matte Polished Base 8040 Upholstered Seat: Designtex, Tour in Trinket 3072-120

GSA/BPA Contract: See Manufacturer's Source List for Manufacturer Contact Information

Sustainability:

DESIGNTEXT TOUR FABRIC: GREENGUARD GOLD, HPD, MINDFUL MATERIALS, NO PROP 65 CHEMICALS, WELL, NO ANTIMICROBIALS, NO FLAME RETARDANTS, NO PFAS, SHIPS CARBON NEUTRAL

FF&E Procurement Information

Item Description: VISUAL DISPLAY BOARD

Item Code: GB1a

Item Picture:

Manufacturer: STEELCASE
Design Series: N/A

Dimensions: 48"W x 48"H
Warranty: LIMITED LIFETIME

Salient Characteristics

EDGE TRIM PROFILE; SMOOTH, GLASS-LIKE SURFACE IS EASY TO CLEAN; SCRATCH-RESISTANT; BACTERIA-RESISTANT; GRAFFITI-RESISTANT; NON-GHOSTING; MAGNETIC



Finish Images



Note - Finishes pictured may vary from item specified

Location and Quantity

OPEN OFFICE 111: 1
 LAB 2 CONTROL 116: 1
 LAB 1 CONTROL 118: 1
 OPEN OFFICE 129: 1

Total Quantity: 4

Finish

Front/Back Surface: Ceramicsteel White E3, High Gloss 7655
 Frame: Anodized Aluminum

GSA/BPA Contract: See Manufacturer's Source List for Manufacturer Contact Information

Sustainability:

SCS INDOOR ADVANTAGE GOLD

FF&E Procurement Information

Item Description: VISUAL DISPLAY BOARD, MOBILE

Item Code: GB1b **Item Picture:**

Manufacturer: STEELCASE
Design Series: N/A
Dimensions: 48"W x 54"H
Warranty: LIMITED LIFETIME

Salient Characteristics

MARKERBOARD; MOBILE; 4 LEG BASE W/ CASTERS; INTEGRATED MARKER TRAY ON TOP; SMOOTH, GLASS-LIKE SURFACE; EASY TO CLEAN; SCRATCH RESISTANT; BACTERIA RESISTANT; GRAFFITI RESISTANT; NON-GHOSTING; MAGNETIC



Finish Images

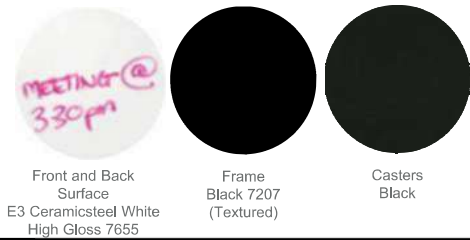

Front and Back Surface: E3 Ceramicsteel White High Gloss 7655
 Frame: Black 7207 (Textured)
 Casters: Black

Note - Finishes pictured may vary from item specified

Location and Quantity

LAB 2 CONTROL 116: 1
 LAB 1 CONTROL 118: 1
 SECURITY 132: 2

Total Quantity: 4

Finish

Front and Back Surface: Ceramicsteel White E3, High Gloss 7655
 Frame: Textured Black (7207)
 Casters: Black

GSA/BPA Contract: See Manufacturer's Source List for Manufacturer Contact Information

Sustainability:

SCS INDOOR ADVANTAGE GOLD

FF&E Procurement Information

Item Description: VISUAL DISPLAY BOARD

Item Code: GB2 **Item Picture:**

Manufacturer: STEELCASE
Design Series: N/A
Dimensions: 39"W x 48"H
Warranty: LIMITED LIFETIME

Salient Characteristics

MARKER TRAY; EDGE TRIM PROFILE; SMOOTH, GLASS-LIKE SURFACE; EASY TO CLEAN; SCRATCH RESISTANT; BACTERIA RESISTANT; GRAFFITI RESISTANT; NO GHOSTING; MAGNETIC



Finish Images



Note - Finishes pictured may vary from item specified

Location and Quantity

OFFICE 112: 1
 OFFICE 113: 1
 OFFICE 130: 1
 COLLATERAL 104: 1

Total Quantity: 4

Finish

Front and Back Surface: Ceramicsteel White E3, High Gloss 7655
 Frame: Anodized Aluminum

GSA/BPA Contract: See Manufacturer's Source List for Manufacturer Contact Information

Sustainability:

SCS INDOOR ADVANTAGE GOLD

FF&E Procurement Information

Item Description: VISUAL DISPLAY BOARD

Item Code: GB3 **Item Picture:**

Manufacturer: STEELCASE
Design Series: N/A

Dimensions: 96"W x 48"H
Warranty: LIMITED LIFETIME

Salient Characteristics

MARKER TRAY; EDGE TRIM PROFILE; SMOOTH, GLASS-LIKE SURFACE; EASY TO CLEAN; SCRATCH RESISTANT; BACTERIA RESISTANT; GRAFFITI RESISTANT; NO GHOSTING; MAGNETIC



Finish Images



Note - Finishes pictured may vary from item specified

Location and Quantity

LARGE CONFERENCE 131: 1

Total Quantity: 1

Finish

Front and Back Surface: Ceramicsteel White E3, High Gloss 7655
 Frame: Anodized Aluminum

GSA/BPA Contract: See Manufacturer's Source List for Manufacturer Contact Information

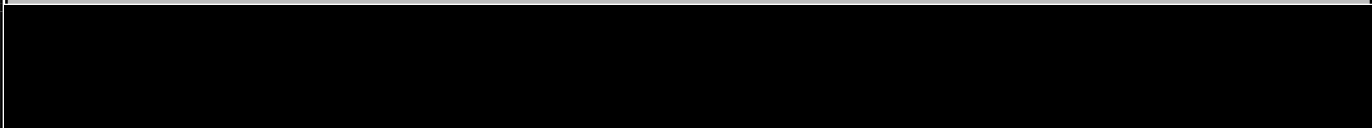

Sustainability:

SCS INDOOR ADVANTAGE GOLD

FF&E Procurement Information

Item Description: COFFEE BREWER, COUNTERTOP

Item Code: K1

Item Picture:

Manufacturer: BUNN

Design Series: N/A

Dimensions: 16.5" W x 22"D x 16.5"H

Warranty: 3 YEAR

Salient Characteristics

PLUMBED; AUTOMATIC WARMER SHUT-OFF; HOT WATER FAUCET; SPLASHGUARD FUNNEL TO PREVENT BURNS TO HANDS; 3 DECANTERS; 1 FUNNEL; 200 OZ TANK FOR BACK-TO-BACK BREWING CAPACITY



Finish Images



Finish
Stainless

Note - Finishes pictured may vary from item specified

Location and Quantity

BREAK ROOM 103: 1

Total Quantity: 1

Finish

STAINLESS STEEL

GSA/BPA Contract: See Manufacturer's Source List for Manufacturer Contact Information

Sustainability:

ENERGY SAVER MODE

FF&E Procurement Information

Item Description: MICROWAVE

Item Code: K2

Item Picture:

Manufacturer: GE

Design Series: N/A

Dimensions: 19"W x 14.25"D x 11.5"H

Warranty: 1 YEAR

Salient Characteristics

COUNTERTOP MOUNTED, .90 CU FT.,
 START/PAUSE, COOKING COMPLETE REMINDER,
 SOUND ON/OFF, CANCEL/OFF, CLOCK - 12HR,
 ADD 30 SECONDS, AUTO & TIME DEFROST,
 EXPRESS COOK - INSTANT-ON - 1-6 MINUTES,
 TIME COOK I & II, CHILD LOCK, 2.45IN DISPLAY
 SCREEN, LED, ELECTRONIC TOUCH, 900W, 120V,
 39" POWER CORD LENGTH, 10 POWER LEVELS,
 10.5"IN GLASS TURNTABLE



Finish Images



Finish
Stainless

Note - Finishes pictured may vary from item specified

Location and Quantity

BREAK ROOM 103: 1

Total Quantity: 1

Finish

STAINLESS STEEL

GSA/BPA Contract: See Manufacturer's Source List for Manufacturer Contact Information

Sustainability:

N/A

FF&E Procurement Information

Item Description: REFRIGERATOR/FREEZER

Item Code: R1

Item Picture:

Manufacturer: GE

Design Series: N/A

Dimensions: 33"W x 34.5"D x 67"H

Warranty: 1 YEAR

Salient Characteristics

COMBINATION REFRIGERATOR/FREEZER; ICE MAKER; ADA COMPLIANT DESIGN; LED INTERIOR LIGHTING; GLASS SHELVES; SLIDING DELI DRAWER; ADJUSTABLE WIRE FREEZER SHELF



Finish Images



Finish
Stainless

Note - Finishes pictured may vary from item specified

Location and Quantity

BREAK ROOM 103: 1

Total Quantity: 1

Finish

Stainless Steel

GSA/BPA Contract: See Manufacturer's Source List for Manufacturer Contact Information

Sustainability:

ENERGY STAR

FF&E Procurement Information

Item Description: UNDERCOUNTER REFRIGERATOR

Item Code: R2

Item Picture:

Manufacturer: U-LINE
Design Series: N/A

Dimensions: 24"W x 23.25"D x 32"H
Warranty: 1 YEAR PARTS/LABOR; 5 YEAR

Salient Characteristics

UNDERCOUNTER REFRIGERATOR; ADA COMPLIANT DESIGN; GLASS DOOR; DIGITAL TOUCH PAD CONTROL; VOLUME OF 5.4 CU. FT.; TEMPERATURE RANGE 34 TO 45 DEGREES FAHRENHEIT; WHITE INTERIOR; LED INTERIOR ILLUMINATION; 3 ADJUSTABLE SHELVES; FIELD-REVERSIBLE DOOR SWING; STANDARD DOOR LOCK; ADJUSTABLE LEVELING LEGS



Finish Images



Finish
Stainless

Note - Finishes pictured may vary from item specified

Location and Quantity

MOTHER'S ROOM 108: 1

Total Quantity: 1

Finish

Stainless Steel

GSA/BPA Contract: See Manufacturer's Source List for Manufacturer Contact Information

Sustainability:

R600a Refrigerant Environmentally Friendly

FF&E Procurement Information

Item Description: SHELVING

Item Code: SH1

Item Picture:

Manufacturer: SAFCO
Design Series: N/A

Dimensions: 36"W x 18"D x 72"H
Warranty: LIMITED LIFETIME

Salient Characteristics

4 EXTRA STRENGTH ADJUSTABLE STEEL SHELVES;
 WELDED WIRE CONSTRUCTION; SHELVES ADJUST
 IN 1" INCREMENTS; 500LB RATING PER SHELF;
 ADJUSTABLE LEVELING FEET W/ PLASTIC CAPS



Contents not included.

Finish Images

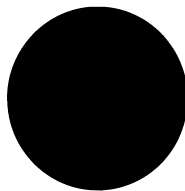

Powder Coat Finish
 Black

Note - Finishes pictured may vary from item specified

Location and Quantity

LOADING AREA 121: 5
 JAN. 106: 1
 STOR. 125: 2

Total Quantity: 8

Finish

Powdercoat Finish: Black

GSA/BPA Contract: See Manufacturer's Source List for Manufacturer Contact Information

Sustainability:

N/A

FF&E Procurement Information

Item Description: CREDENZA, MEDIA STORAGE

Item Code: ST1 **Item Picture:**

Manufacturer: STEELCASE
Design Series: N/A

Dimensions: 24"D x 72"W
Warranty: LIMITED LIFETIME

Salient Characteristics

4 DOORS, REAR SLOTS FOR VENTING, KEYED LOCK, LAMINATE TOP, LAMINATE BASE

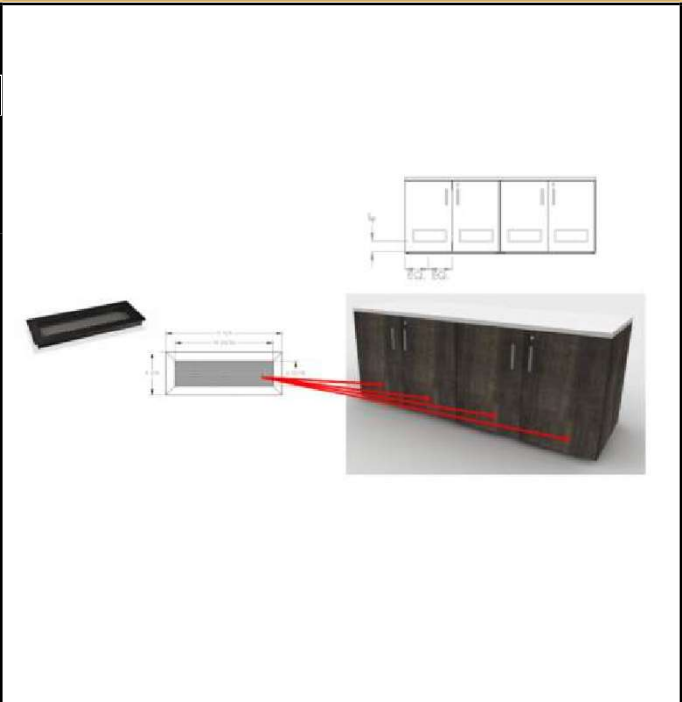

Finish Images

 SEE FOLLOWING PAGE

Note - Finishes pictured may vary from item specified

Location and Quantity

LARGE CONFERENCE 131: 1

Total Quantity: 1

Finish

Top: Steelcase Laminate, Sheetrock 2UH6
 Base: Steelcase Laminate, Storm Noce 2HSN
 Door Pull: Painted Metal, Platinum Mettalic 4799

GSA/BPA Contract: See Manufacturer's Source List for Manufacturer Contact Information

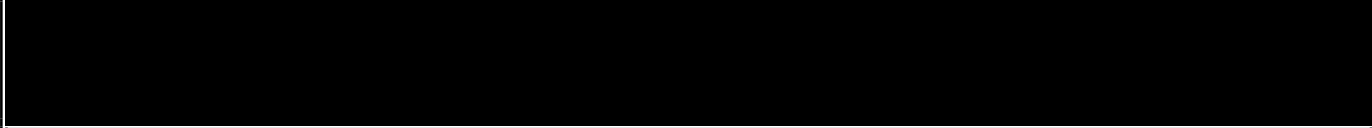

Sustainability:

BIFMA LEVEL 3, SCS INDOOR ADVANTAGE GOLD

Finish Images



HPL Top
Sheetrock
2UH6
(Textured)



3mm Edge
Sheetrock 6T12



HPL Case & Doors
Storm Noce 2HSN



Pull Style
Ledge

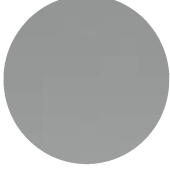

Painted Pull
Platinum Metallic
4799
(Smooth Metallic)

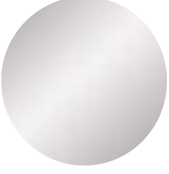

Lock Finish
Polished Chrome
9201

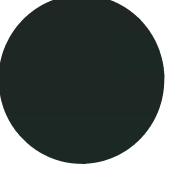

Mockett Vent
Matte Black 90M

FF&E Procurement Information

Item Description: LATERAL FILE, 5 HIGH

Item Code: ST2a

Item Picture:

Manufacturer: STEELCASE
Design Series: N/A



Warranty: LIMITED LIFETIME

Salient Characteristics

FOUR 12"H DRAWERS; ONE 13.5"H DOOR W/
 FIXED SHELF; 2 HANGING FOLDER BARS TO
 ACCOMMODATE SIDE-TO-SIDE FILING OF
 LETTER; A4 INTERNATIONAL AND LEGAL SIZE
 HANGING FOLDERS; FLUSH STEEL FRONT;
 LOCKABLE; ANTI-TIP

Finish Images

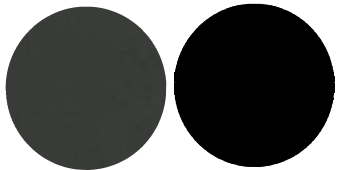

Painted Case &
 Drawers
 Merle 7360
 (Textured)

Lock Finish
 Ember Chrome 9250

Note - Finishes pictured may vary from item specified

Location and Quantity

OPEN OFFICE 129: 3

Total Quantity: 3

Finish

Painted Metal: Steelcase Merle 7360

GSA/BPA Contract: See Manufacturer's Source List for Manufacturer Contact Information

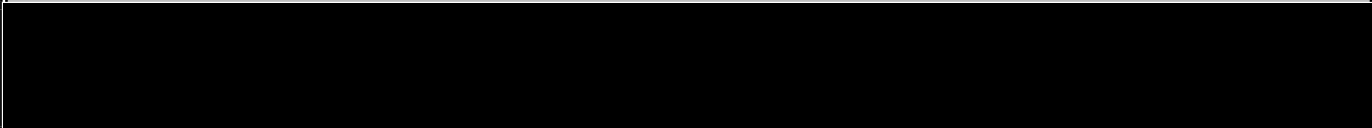

Sustainability:

BIFMA LEVEL 3, SCS INDOOR ADVANTAGE GOLD, HHI, DECLARE LABEL

FF&E Procurement Information

Item Description: LATERAL FILE, 2 HIGH

Item Code: ST2b

Item Picture:

Manufacturer: STEELCASE

Design Series: N/A

Warranty: LIMITED LIFETIME

Salient Characteristics

TWO 12"H DRAWERS; 3/16" LAMINATE TOP; TWO HANGING FOLDER BARS TO ACCOMMODATE SIDE-TO-SIDE FILING OF LETTER, A4 INTERNATIONAL AND LEGAL-SIZE HANGING FOLDERS; FLUSH STEEL FRONT; LOCKABLE, ANTI-TIP



Finish Images



Painted Case & Drawers
Merle 7360
(Textured)

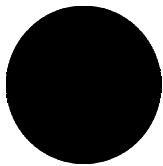

Lock Finish
Ember Chrome 9250



HPL Top
Milk 2884



3mm Edge
Milk 6052

Note - Finishes pictured may vary from item specified

Location and Quantity

OPEN OFFICE 111: 1
 OPEN OFFICE 120: 5

Total Quantity: 6

Finish

Base: Steelcase painted metal in Merle 7360 Common Top: Steelcase solid laminate in Milk 2884

GSA/BPA Contract: See Manufacturer's Source List for Manufacturer Contact Information

Sustainability:

BIFMA LEVEL 3, SCS INDOOR ADVANTAGE GOLD, HHI, DECLARE

FF&E Procurement Information

Item Description: STORAGE CABINET, 2 DOOR

Item Code: ST3

Item Picture:

Manufacturer: STEELCASE

Design Series: N/A

Warranty: LIMITED LIFETIME

Salient Characteristics

2 DOOR, PAINTED METAL, 5 ADJUSTABLE SHELVES,
 ANTI-TIP; LOCKABLE , FLUSH STEEL FRONT



Finish Images

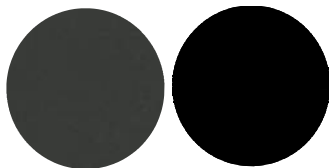

Painted Case &
 Drawers
 Merle 7360
 (Textured)

Lock Finish
 Ember Chrome 9250

Note - Finishes pictured may vary from item specified

Location and Quantity

OPEN OFFICE 111: 1
 OPEN OFFICE 129: 1

Total Quantity: 2

Finish

Painted Metal: Steelcase Merle 7360

GSA/BPA Contract: See Manufacturer's Source List for Manufacturer Contact Information

Sustainability:

BIFMA LEVEL 3, SCS INDOOR ADVANTAGE GOLD, HHI, DECLARE LABEL

FF&E Procurement Information

Item Description: STORAGE COMBINATION UNIT: FF, GENERAL STORAGE

Item Code: ST5

Item Picture:

Manufacturer: STEELCASE
Design Series: N/A

Dimensions: 24"D x16"W x 66.5"H
Warranty: LIMITED LIFETIME

Salient Characteristics

FILE FILE, GENERAL STORAGE, LAMINATE FINISH, LOCKABLE



Finish Images

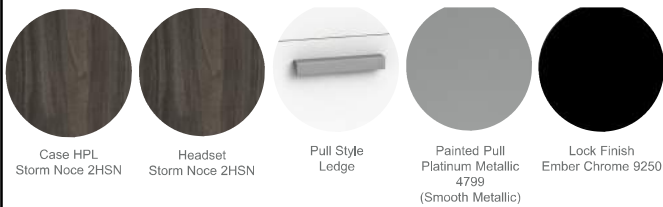

Note - Finishes pictured may vary from item specified

Location and Quantity

OFFICE 112: 1
 OFFICE 113: 1
 OFFICE 130: 1

Total Quantity: 3

Finish

Body: Steelcase Laminate Woodgrain, Storm Noce 2HSN
 Door/Drawer Pulls: Painted Metal, Platinum Metallic 4799

GSA/BPA Contract: See Manufacturer's Source List for Manufacturer Contact Information

Sustainability:

BIFMA LEVEL 3, SCS INDOOR ADVANTAGE GOLD

FF&E Procurement Information

Item Description: MOBILE BOX-FILE PEDESTAL

Item Code: ST6 **Item Picture:**

Manufacturer: STEELCASE
Design Series: N/A

Dimensions: 17.5"D x 15"W
Warranty: LIMITED LIFETIME

Salient Characteristics

MOBILE, 1 BOX DRAWER W/ DIVIDER, 1 FILE DRAWER TO ACCOMMODATE FRONT-TO-BACK LETTER-SIZE HANGING FILES, FLUSH STEEL FRONT, 4 NON-LOCKING CASTERS, CUSHION TOP 22 5/8"D x 15"W x 1"H



Finish Images

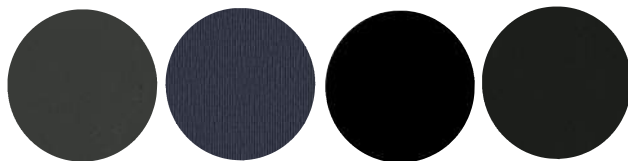

Painted Case & Drawers Merle 7360 (Textured)
 Cushion Upholstery Gr. 6 Design Tex Mateo Dark Blue 3895-402
 Lock Finish Ember Chrome 9250
 Casters Black

Note - Finishes pictured may vary from item specified

Location and Quantity

OFFICE 112: 1
 OFFICE 113: 1
 OFFICE 130: 1

Total Quantity: 3

Finish

Metal: Steelcase Merle 7360 Cushion Top: Designtex, Mateo Dark Blue 3895-402

GSA/BPA Contract: See Manufacturer's Source List for Manufacturer Contact Information

Sustainability:

BIFMA LEVEL 3, SCS INDOOR ADVANTAGE GOLD, HHI, DECLARE LABEL

FF&E Procurement Information

Item Description: CONFERENCE TABLE, POWERED

Item Code: T1 **Item Picture:**

Manufacturer: STEELCASE

Dimensions: 48"D x 180"W x 29"H
Warranty: LIMITED LIFETIME

Salient Characteristics

FACETED, WORKING HEIGHT; 2-PIECE TOP; 36"W METAL BASES; 2 UTILITY BAYS FOR POWER/DATA AT 7.5"W x 19 5/8" EACH W/ BUTTON-ACTUATED DOOR, SOFT COMPRESSIBLE CUSHIONS OF BLACK SANTOPRENE LINE THE DOORS ALLOWING FOR 3/8" CABLES TO PASS THROUGH THE DOORS; 2 DUPLEX POWER OUTLETS PER UTILITY BAY; EACH UTILITY BAY HAS OPENINGS FOR TWO CUSTOMER-SUPPLIED STANDARD ARCHITECTURAL FACEPLATES, VOICE/DATA FACEPLATE OPENING HAS UNIVERSAL ADAPTER W/ REMOVABLE PLATES ALLOWING SINGLE-GANG SIZE OF 2"W X 4"H, DOUBLE-GANG SIZE OF 6"W x 4"H, FACEPLATES THAT PROVIDE NETWORK, TELEPHONE AND AUDIO-VISUAL OUTLETS ARE AVAILABLE FROM VARIOUS TECHNOLOGY SUPPLIERS.



Finish Images



Note - Finishes pictured may vary from item specified

Location and Quantity

LARGE CONFERENCE 131: 1

Total Quantity: 1

Finish

Base: Steelcase Painted Metal, Anthracite Textured
 Top: Steelcase Laminate Woodgrain, Storm Noce 2HSN/2LSN
 Power bay: Steelcase Charcoal Mica 4747

GSA/BPA Contract: See Manufacturer's Source List for Manufacturer Contact Information

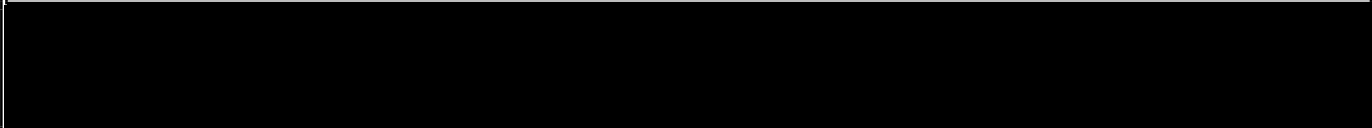

Sustainability:

BIFMA LEVEL 1, LEED, WELL

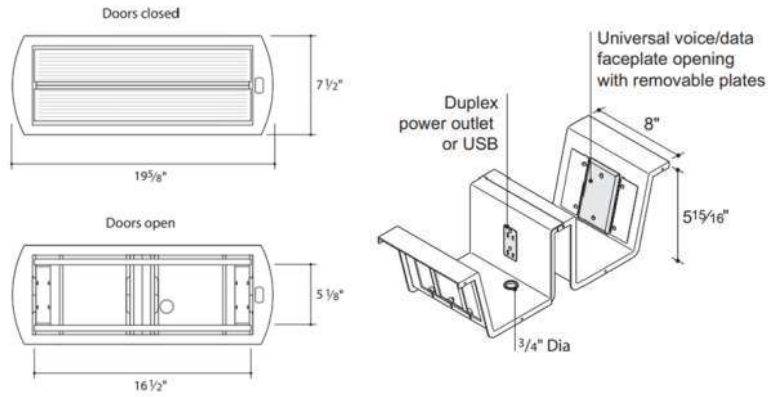

Three-Circuit, 3+0.

Circuit Panel 1

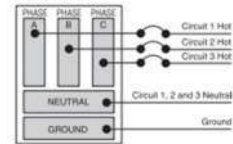

In the three-circuit, 3+0 schematic, circuits 1, 2, and 3 are distributed from the first circuit panel and are supported with one shared neutral and one shared ground.

Single 3-Phase

Circuit Panel

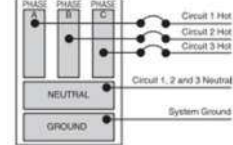

On a single 3-phase circuit panel, all three circuits are distributed as shown.

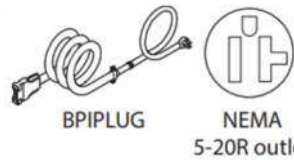
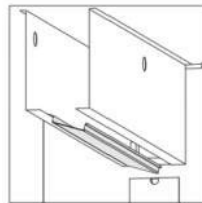
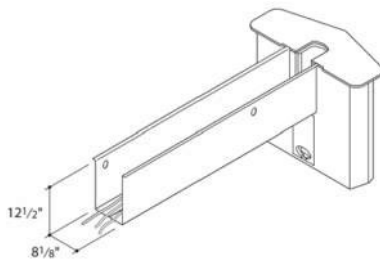

Single circuit plug, 20-amp, base power-in, 3+0 wiring schematic is available on tables with one, two, three, or four utility bays. This offers the quickest, easiest installation of tables. An electrician must provide a NEMA 5-20R outlet for each row within 18" of the infeed location. The single circuit plug is U.L. recognized.

FF&E Procurement Information

Item Description: TABLE, SQUARE

Item Code: T2

Item Picture:

Manufacturer: STEELCASE

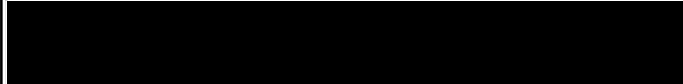

Dimensions: 30"W x 30"D x 28.5"H

Warranty: LIMITED LIFETIME

Salient Characteristics

LAMINATE TOP, PAINTED METAL BASE



Finish Images



HPL Top
Milk 2884



3mm Edge
Milk 6052



Painted Base
Merle 7360
(Textured)

Note - Finishes pictured may vary from item specified

Location and Quantity

BREAK ROOM 103: 1

Total Quantity: 1

Finish

Top: Steelcase Laminate Solid in Milk 2884 Base: Steelcase, Painted Metal in Merle 7360

GSA/BPA Contract: See Manufacturer's Source List for Manufacturer Contact Information

Sustainability:

EPD; BIFMA LEVEL 3, SCS INDOOR ADVANTAGE GOLD, HHI

FF&E Procurement Information

Item Description: TABLE, TRAINING, FLIP-TOP

Item Code: T3

Item Picture:

Manufacturer: STEELCASE



Dimensions: 24"D x 60"W x 34.7"H

Warranty: LIMITED LIFETIME

Salient Characteristics

STANDING HEIGHT ADJUSTABLE LEG, LEVELERS, ADJUSTS 27 3/8"H TO 44"H



Finish Images



HPL Top
Milk 2884

Edge
Milk 6052

Painted Base
Merle 7360

Note - Finishes pictured may vary from item specified

Location and Quantity

COLLATERAL 104: 1

Total Quantity: 1

Finish

Top: Steelcase Laminate Solid in Milk 2884 Base: Steelcase, Painted Metal in Merle 7360

GSA/BPA Contract: See Manufacturer's Source List for Manufacturer Contact Information

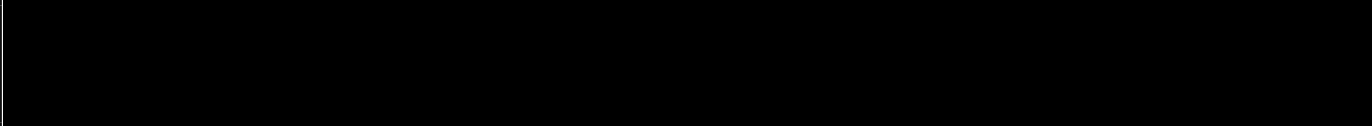

Sustainability:

BIFMA LEVEL 3, SCS INDOOR ADVANTAGE, HHI

FF&E Procurement Information

Item Description: WASTEBASKET

Item Code: WB1

Item Picture:

Manufacturer: GLOBAL INDUSTRIAL

Design Series: N/A

Dimensions: 14.5"W x 10.5"D x 15"H

Warranty: LIMITED 10 YEAR

Salient Characteristics

ROLLED RIM, 7 GAL; ROUNDED CORNERS FOR EXTRA STRENGTH



Finish Images



Plastic Color
Black

Note - Finishes pictured may vary from item specified

Location and Quantity

COLATERAL 104: 6	LAB 1 CONTROL 118: 6
MOTHER'S ROOM 108:1	OPEN OFFICE 129: 9
OPEN OFFICE 111: 15	OFFICE130: 1
OFFICE 112: 1	LARGE CONFERENCE 131: 1
OFFICE 113: 1	SECURITY 132: 4
LAB 2 CONTROL 116: 6	

Total Quantity: 51

Finish

Plastic: BLACK

GSA/BPA Contract: See Manufacturer's Source List for Manufacturer Contact Information

Sustainability:

N/A

FF&E Procurement Information

Item Description: WASTEBASKET, COMBINATION

Item Code: WB2

Item Picture:

Manufacturer: MAGNUSON

Dimensions: 38"H x 50.6"W x 18"D

Warranty: 2 YEAR

Salient Characteristics

2 EA. 38 GAL. WASTE BIN W/ SINGLE TOP OPENING, INTEGRATED BAG ARMS & NON-SKID GLIDES; 2 - WASTE TOP OPENINGS; STANDARD ENGLISH LABELS (WASTE) IN WHITE VINYL; LINERS.



Finish Images

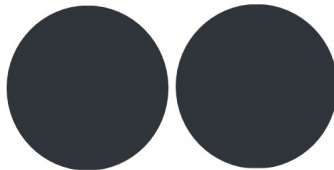

Body Color
Dark Anthracite

Top Color
Dark Anthracite

Note - Finishes pictured may vary from item specified

Location and Quantity

BREAK ROOM 103: 1

Total Quantity: 1

Finish

Body Color: Dark Anthracite Top Color: Dark Anthracite

GSA/BPA Contract: See Manufacturer's Source List for Manufacturer Contact Information

Sustainability:

N/A

FF&E Procurement Information

Item Description: 99W x 34D STRAIGHT, PANEL-BASED WORKSTATION

Item Code: WS1.A

Item Picture:

Manufacturer: STEELCASE

Dimensions: 99"W x 34"D x 60"H

Warranty: LIMITED LIFETIME

Salient Characteristics

60"H PANELS. PANELS ALONG DRYWALL TO HAVE BOTTOM 18" FABRIC TILE REMOVED ON BOTH SIDES FOR ACCESS TO WALL OUTLETS/CONDUIT. FABRIC INTERIOR, LAMINATE EXTERIOR AT AISLES. WING PANEL ALONG AISLE, 18"H LAMINATE SKIN & 36"H MARKERBOARD SKIN W/ MARKERBOARD KIT/TOOLBAR. 30"D X 90"W STRAIGHT WORKSURFACE W/ 1/2" CORD DROP EDGE. 4 - FLEXA BUILD HEAVY DUTY MONITOR ARMS, EXTENSION ARM, POLE CLAMP. 2 FLEXA SERIES EXTENSION POLE, CLAMP BASE. 1—FIXED PEDESTAL BOX/BOX/FILE, ACCOMMODATES FRONT-TO-BACK LETTER-SIZE HANGING FILE, FLUSH STEEL FRONT, LOCKING, COUNTERWEIGHT, 28 5/8"D X 15"W X 27"H. FIXED 2-DRAWER LATERAL, ACCOMODATES SIDE-TO-SIDE FILING OF LETTER, A4 INTERNATIONAL AND LEGAL-SIZE HANGING FOLDERS, FLUSH STEEL FRONT, LOCKING, COUNTERWEIGHT, 24"D X 30"W X 28"H. 2 - MOBILE PEDESTAL BOX/FILE, ACCOMMODATES FRONT-TO-BACK LETTER-SIZE HANGING FILE, FLUSH STEEL FRONT, LOCKING, COUNTERWEIGHT, 28 5/8"D X 15"W X 20"H.



Finish Images

SEE FOLLOWING PAGE

Note - Finishes pictured may vary from item specified

Location and Quantity

SECURITY 132: 2

Total Quantity: 2

Finish

Worksurface: Steelcase Laminate Solid in Milk 2884
 Metal Panel Trim: Merle
 Exterior Panel: Steelcase Laminate Woodgrain in Storm Noce 2HSN/2LSN
 Tack Fabric: Steelcase Classics Collection, Sprite in Linen 5543

GSAB/PA Contract: See Manufacturer's Source List for Manufacturer Contact Information

Sustainability:

BIFMA LEVEL 3, SCS INDOOR ADVANTAGE GOLD, HHI, DECLARE LABEL

Finish Images



HPL Top
Milk 2884



3mm Edge
Milk 6052



Storage Painted
Case & Drawers
Merie 7360
(Textured)



Lock Finish
Ember Chrome 9250



Fabric Panel Skin
Gr. A -Sprite Liner
5543



HPL Panel Skin
Storm Noce 2HSN



Monitor Arm
Matte Black



Markerboard



FF&E Procurement Information

Item Description: 108W x 102D x 60H CORNER, PANEL-BASED WORKSTATION

Item Code: WS2a.A **Item Picture:**

Manufacturer: STEELCASE



Dimensions: 108W X 102D X 60H

Warranty: LIMITED LIFETIME

Salient Characteristics

60"H PANELS. PANELS ALONG DRYWALL TO HAVE BOTTOM 18" FABRIC TILE REMOVED ON BOTH SIDES FOR ACCESS TO WALL OUTLETS/CONDUIT. 30"D x 102"W STRAIGHT WORKSURFACE W/ 1/2" CORD DROP EDGE. 30"D X 66"W STRAIGHT WORKSURFACE W/ 1/2" CORD DROP EDGE. 4 - FLEXA BUILD HEAVY DUTY MONITOR ARMS, EXTENSION ARM, POLE CLAMP. 2 FLEXA SERIES EXTENSION POLE, CLAMP BASE. 1 - ~~FIXED PEDESTAL BOX/BOX/FILE, ACCOMMODATES FRONT-TO-BACK LETTER-SIZE HANGING FILE, FLUSH STEEL FRONT, LOCKING, COUNTERWEIGHT, 28 5/8"D X 15"W X 27"H.~~ FIXED 2 DRAWER LATERAL, ACCOMODATES SIDE-TO-SIDE FILING OF LETTER, A4 INTERNATION AND LEGAL-SIZE HANGING FOLDERS, FLUSH STEEL FRONT, LOCKING, COUNTERWEIGHT, 24"D X 30"W X 28"H. **1 - MOBILE PEDESTAL BOX/FILE, ACCOMMODATES FRONT-TO-BACK LETTER-SIZE HANGING FILE, FLUSH STEEL FRONT, LOCKING, COUNTERWEIGHT, 28 5/8"D X 15"W X 20"H.**

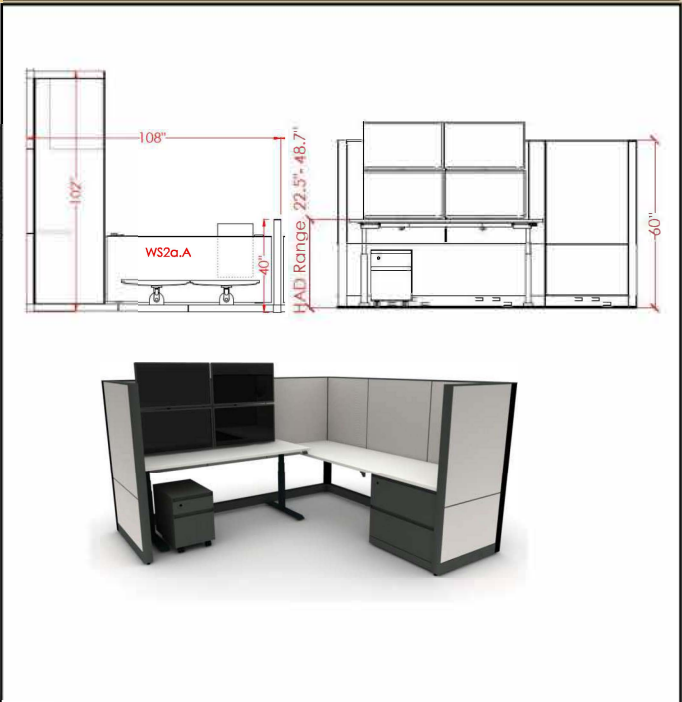

Finish Images
 SEE FOLLOWING PAGE

Note - Finishes pictured may vary from item specified

Location and Quantity

SECURITY 132: 1

Total Quantity: 1

Finish

Worksurface: Steelcase Laminate Solid in Milk 2884
 Metal Panel Trim: Merle
 Exterior Panel: Steelcase Laminate Woodgrain in Storm Noce 2HSN/2LSN
 Tack Fabric: Steelcase Classics Collection, Sprite in Linen 5544

GSAB/PA Contract: See Manufacturer's Source List for Manufacturer Contact Information



Sustainability:

BIFMA LEVEL 3, SCS INDOOR ADVANTAGE GOLD, HHI, DECLARE LABEL

Finish Images



HPL Top
Milk 2884



3mm Edge
Milk 6052



Storage Painted
Case & Drawers
Merle 7360
(Textured)



Lock Finish
Ember Chrome 9250



Fabric Panel Skin
Gr. A -Sprite Linen
5543



Monitor Arm
Matte Black



Finish Images



HPL Top
Milk 2884



3mm Edge
Milk 6052



Storage Painted
Case & Drawers
Merle 7360
(Textured)



Lock Finish
Ember Chrome 9250



Fabric Panel Skin
Gr. A -Sprite Linen
5543



Monitor Arm
Matte Black



FF&E Procurement Information

Item Description: 114W x 102D x 48H/60H U-SHAPED, PANEL-BASED WORKSTATION

Item Code: WS3a.A

Item Picture:

Manufacturer: STEELCASE

Dimensions: 114W X 102D X 48H/60H

Warranty: LIMITED LIFETIME

Salient Characteristics

48"H & 60"H PANELS. PANELS ALONG DRYWALL TO HAVE BOTTOM 18" FABRIC TILE REMOVED ON BOTH SIDES FOR ACCESS TO WALL OUTLETS/CONDUIT. 30"D X 78"W STRAIGHT WORKSURFACE W/ 1/2" CORD DROP EDGE. 30"D X 42"W STRAIGHT WORKSURFACE W/ 1/2" CORD DROP EDGE. 30"D X 96"W STRAIGHT WORKSURFACE W/ 1/2" CORD DROP EDGE. 4 - FLEXA BUILD HEAVY DUTY MONITOR ARMS, EXTENSION ARM, POLE CLAMP. 2 FLEXA SERIES EXTENSION POLE, CLAMP BASE. 1 - OVERHEAD BIN, 30"W X 16"D. 1 - OVERHEAD BIN, 66"W X 16"D. OVERHEAD SHELF - 30"W & 42"W. 1 - FIXED PEDESTAL BOX/BOX/FILE, ACCOMMODATES FRONT-TO-BACK LETTER-SIZE HANGING FILE, FLUSH STEEL FRONT, LOCKING, COUNTERWEIGHT, 28 5/8"D X 15"W X 27"H. 1 - FIXED PEDESTAL FILE/FILE, ACCOMMODATES FRONT-TO-BACK LETTER-SIZE HANGING FILE, FLUSH STEEL FRONT, LOCKING, COUNTERWEIGHT, 28 5/8"D X 15"W X 27"H. FIXED 2 DRAWER LATERAL, ACCOMODATES SIDE-TO-SIDE FILING OF LETTER, A4 INTERNATION AND LEGAL-SIZE HANGING FOLDERS, FLUSH STEEL FRONT, LOCKING, COUNTERWEIGHT, 24"D X 30"W X 28"H.

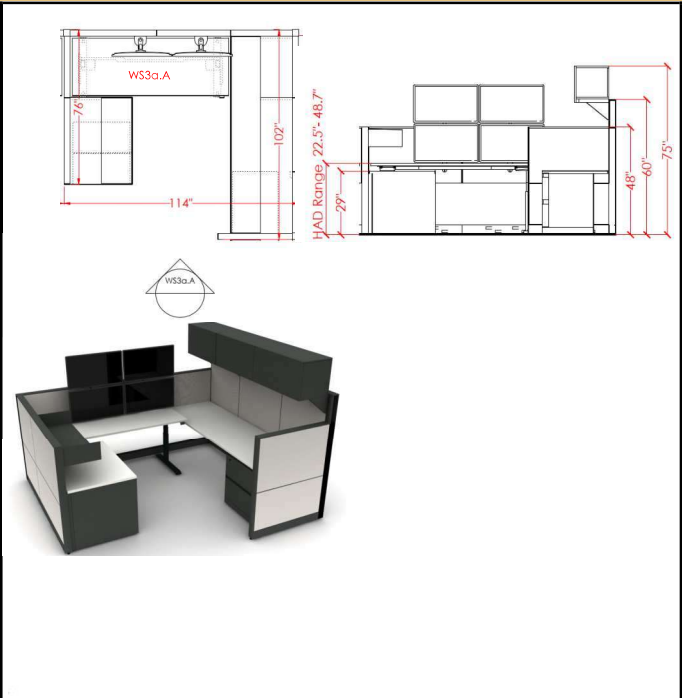

Finish Images

SEE FOLLOWING PAGE

Note - Finishes pictured may vary from item specified

Location and Quantity

OPEN OFFICE 129: 1

Total Quantity: 1

Finish

Worksurface: Steelcase Laminate Solid in Milk 2884
 Metal Panel Trim: Merle
 Exterior Panel: Steelcase Laminate Woodgrain in Storm Noce 2HSN/2LSN
 Tack Fabric: Steelcase Classics Collection, Sprite in Linen 5545

GSA/BPA Contract: See Manufacturer's Source List for Manufacturer Contact Information

Sustainability:

BIFMA LEVEL 3, SCS INDOOR ADVANTAGE GOLD, HHI, DECLARE LABEL

Finish Images



HPL Top
Milk 2884



3mm Edge
Milk 6052



Storage Painted
Case & Drawers
Merle 7360
(Textured)



Lock Finish
Ember Chrome 9250



Fabric Panel Skin
Gr. A -Sprite Linen
5543



Monitor Arm
Matte Black



FF&E Procurement Information

Item Description: 114W x 99D x 48H/60H U-SHAPED, PANEL-BASED WORKSTATION

Item Code: WS3b.A

Item Picture:

Manufacturer: STEELCASE

Dimensions: 114W X 99D X 48H/60H

Warranty: LIMITED LIFETIME

Salient Characteristics

48"H & 60"H PANELS. PANELS ALONG DRYWALL TO HAVE BOTTOM 18" FABRIC TILE REMOVED ON BOTH SIDES FOR ACCESS TO WALL OUTLETS/CONDUIT. 30"D X 78"W STRAIGHT WORKSURFACE W/ 1/2" CORD DROP EDGE. 30"D X 42"W STRAIGHT WORKSURFACE W/ 1/2" CORD DROP EDGE. 30"D X 96"W STRAIGHT WORKSURFACE W/ 1/2" CORD DROP EDGE. 4 - FLEXA BUILD HEAVY DUTY MONITOR ARMS, EXTENSION ARM, POLE CLAMP. 2 FLEXA SERIES EXTENSION POLE, CLAMP BASE. 1 - OVERHEAD BIN, 30"W X 16"D. 1 - OVERHEAD BIN, 66"W X 16"D. OVERHEAD SHELF - 30"W & 42"W. 1 - FIXED PEDESTAL BOX/BOX/FILE, ACCOMMODATES FRONT-TO-BACK LETTER-SIZE HANGING FILE, FLUSH STEEL FRONT, LOCKING, COUNTERWEIGHT, 28 5/8"D X 15"W X 27"H. 1 - FIXED PEDESTAL FILE/FILE, ACCOMMODATES FRONT-TO-BACK LETTER-SIZE HANGING FILE, FLUSH STEEL FRONT, LOCKING, COUNTERWEIGHT, 28 5/8"D X 15"W X 27"H. FIXED 2 DRAWER LATERAL, ACCOMODATES SIDE-TO-SIDE FILING OF LETTER, A4 INTERNATIONAL AND LEGAL-SIZE HANGING FOLDERS, FLUSH STEEL FRONT, LOCKING, COUNTERWEIGHT, 24"D X 30"W X 28"H.

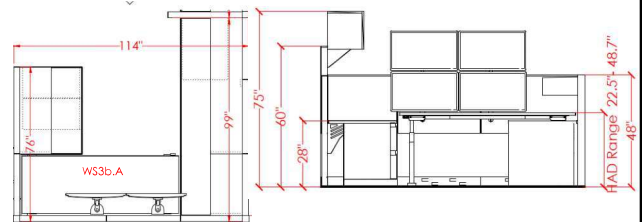

Finish Images

SEE FOLLOWING PAGE

Note - Finishes pictured may vary from item specified

Location and Quantity

OPEN OFFICE 129: 1

Total Quantity: 1

Finish

Worksurface: Steelcase Laminate Solid in Milk 2884Metal Panel Trim: MerleExterior Panel: Steelcase Laminate Wo

GSA/BPA Contract: See Manufacturer's Source List for Manufacturer Contact Information

Sustainability:

BIFMA LEVEL 3, SCS INDOOR ADVANTAGE GOLD, HHI, DECLARE LABEL

Finish Images



HPL Top
Milk 2884



3mm Edge
Milk 6052



Storage Painted
Case & Drawers
Merle 7360
(Textured)



Lock Finish
Ember Chrome 9250



Fabric Panel Skin
Gr. A -Sprite Linen
5543



Monitor Arm
Matte Black



FF&E Procurement Information

Item Description: 78W x 34D x 54H STRAIGHT, PANEL-BASED WORKSTATION

Item Code: WS4b

Item Picture:

Manufacturer: STEELCASE

Dimensions: 78W X 34D X 54H

Warranty: LIMITED LIFETIME

Salient Characteristics

54"H PANELS. PANELS ALONG DRYWALL TO HAVE BOTTOM 18" FABRIC TILE REMOVED ON BOTH SIDES FOR ACCESS TO WALL OUTLETS/CONDUIT. 30"D X 72"W STRAIGHT WORKSURFACE W/ 1/2" CORD DROP EDGE. 4 - FLEXA BUILD HEAVY DUTY MONITOR ARMS, EXTENSION ARM, POLE CLAMP. 2 FLEXA SERIES EXTENSION POLE, CLAMP BASE. 1 - FIXED PEDESTAL BOX/BOX/FILE, ACCOMMODATES FRONT-TO-BACK LETTER-SIZE HANGING FILE, FLUSH STEEL FRONT, LOCKING, COUNTERWEIGHT, 28 5/8"D X 15"W X 27"H. 1 - FIXED PEDESTAL FILE/FILE, ACCOMMODATES FRONT-TO-BACK LETTER-SIZE HANGING FILE, FLUSH STEEL FRONT, LOCKING, COUNTERWEIGHT, 28 5/8"D X 15"W X 27"H.

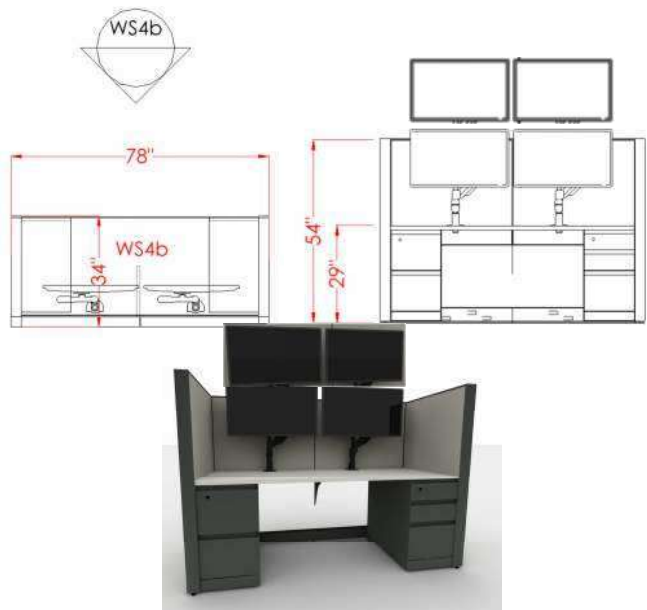

Finish Images

SEE FOLLOWING PAGE

Note - Finishes pictured may vary from item specified

Location and Quantity

COLLATERAL 104: 4

Total Quantity: 4

Finish

Worksurface: Steelcase Laminate Solid in Milk 2884Metal Panel Trim: MerleExterior Panel: Steelcase Laminate Wo

GSA/BPA Contract: See Manufacturer's Source List for Manufacturer Contact Information

Sustainability:

BIFMA LEVEL 3, SCS INDOOR ADVANTAGE GOLD, HHI, DECLARE LABEL

Finish Images



HPL Top
Milk 2884



3mm Edge
Milk 6052



Storage Painted
Case & Drawers
Merle 7360
(Textured)



Lock Finish
Ember Chrome 9250



Fabric Panel Skin
Gr. A -Sprite Linen
5543



Monitor Arm
Matte Black



FF&E Procurement Information

Item Description: 75W x 75D x 60H, CORNER, PANEL-BASED WORKSTATION

Item Code: WS6

Item Picture:

Manufacturer: STEELCASE

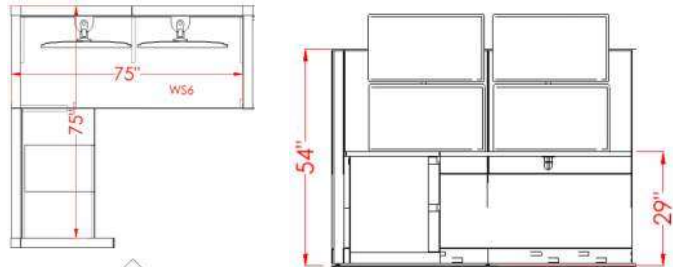

Dimensions: 75W x 75D x 60H

Warranty: LIMITED LIFETIME

Salient Characteristics

54"H PANELS. PANELS ALONG DRYWALL TO HAVE BOTTOM 18" FABRIC TILE REMOVED ON BOTH SIDES FOR ACCESS TO WALL OUTLETS/CONDUIT. 30"D X 72"W STRAIGHT WORKSURFACE W/ 1/2" CORD DROP EDGE. 24"D X 42"W STRAIGHT WORKSURFACE W/ 1/2" CORD DROP EDGE. 4 - FLEXA BUILD HEAVY DUTY MONITOR ARMS, EXTENSION ARM, POLE CLAMP. 2 FLEXA SERIES EXTENSION POLE, CLAMP BASE. 1 - FIXED PEDESTAL BOX/BOX/FILE, ACCOMMODATES FRONT-TO-BACK LETTER-SIZE HANGING FILE, FLUSH STEEL FRONT, LOCKING, COUNTERWEIGHT, 28 5/8"D X 15"W X 27"H. 1 - FIXED PEDESTAL FILE/FILE, ACCOMMODATES FRONT-TO-BACK LETTER-SIZE HANGING FILE, FLUSH STEEL FRONT, LOCKING, COUNTERWEIGHT, 28 5/8"D X 15"W X 27"H.



Finish Images

SEE FOLLOWING PAGE

Note - Finishes pictured may vary from item specified

Location and Quantity

COLLATERAL 104: 2

Total Quantity: 2

Finish

Worksurface: Steelcase Laminate Solid in Milk 2884

Metal Panel Trim: Merle

Exterior Panel: Steelcase Laminate Woodgrain in Storm Noce 2HSN/2LSN

Tack Fabric: Steelcase Classics Collection, Sprite in Linen 5548

GSA/BPA Contract: See Manufacturer's Source List for Manufacturer Contact Information

Sustainability:

BIFMA LEVEL 3, SCS INDOOR ADVANTAGE GOLD, HHI, DECLARE LABEL

Finish Images



HPL Top
Milk 2884



3mm Edge
Milk 6052



Storage Painted
Case & Drawers
Merle 7360
(Textured)



Lock Finish
Ember Chrome 9250



Fabric Panel Skin
Gr. A -Sprite Linen
5543



Monitor Arm
Matte Black



FF&E Procurement Information

Item Description: 56W x 66D x 28.5H L-SHAPE, FREESTANDING WORKSTATION

Item Code: WS7.A

Item Picture:

Manufacturer: STEELCASE

Model: N/A

Dimensions: 56W x 66D x 28.5H

Warranty: LIMITED LIFETIME

Salient Characteristics

DESK SHELL 30"D X 56"W W/ 1.125" THICK SURFACE. RETURN SHELL 24"D X 36"W RIGHT OR LEFT HAND. FULL MODESTY PANEL. WALL MOUNTED TACK BOARD - 24"H X 36"W. 4 - FLEXA BUILD HEAVY DUTY MONITOR ARMS, EXTENSION ARM, POLE CLAMP. 2 FLEXA SERIES EXTENSION POLE, CLAMP BASE. 1 - OVERHEAD BIN, 36"W, HINGED DOORS.

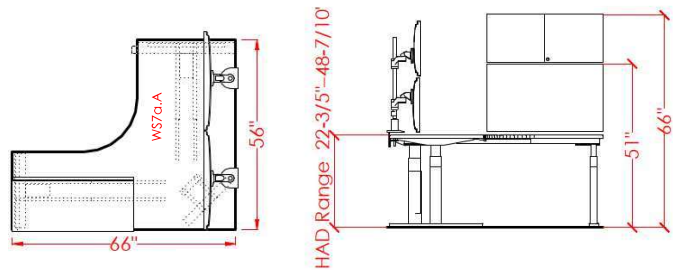

Finish Images

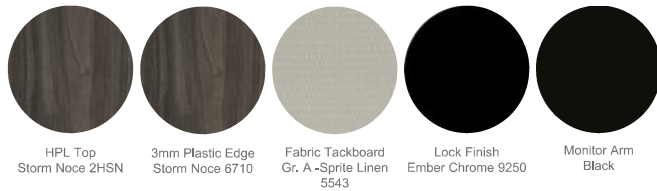

Note - Finishes pictured may vary from item specified

Location and Quantity

OFFICE 112: 1
 OFFICE 113: 1
 OFFICE 130: 1

Total Quantity: 3

Finish

Worksurface: Steelcase Woodgrain in Storm Noce 2HSN/2LSN Metal Panel Trim: Merle

GSA/BPA Contract: See Manufacturer's Source List for Manufacturer Contact Information

Sustainability:

BIFMA LEVEL 3, SCS INDOOR ADVANTAGE GOLD

FF&E Procurement Information

Item Description: 64"D x 105"W x 48"H, U-SHAPE PANEL-BASED WORKSTATION

Item Code: WS8a.A

Item Picture:

Manufacturer: STEELCASE

Dimensions: 64"D x 105"W x 48"H

Warranty: LIMITED LIFETIME

Salient Characteristics

48"H PANELS. HORIZONTAL REVEAL AT 23" AFF. PANELS AGAINST DRYWALL TO HAVE BOTTOM 18"H FABRIC TILE REMOVED ON BOTH SIDES FOR ACCESS TO WALL OUTLETS/CONDUIT. WING PANEL ALONG AISLE, 18"H LAMINATE SKIN AND 24"H MARKERBOARD SKIN WITH MARKER KIT/TOOLBAR. 30"D X 60"W STRAIGHT WORKSURFACE W/ 1/2" CORD DROP EDGE. 18.875"D X 48"W STRAIGHT WORKSURFACE WITH 1/2" CORD DROP EDGE. 24"D X 60"W STRAIGHT WORKSURFACE W/ 1/2" CORD DROP EDGE. 4 - FLEXA BUILD HEAVY DUTY MONITOR ARM, EXTENSION ARM, POLE CLAMP. 2 - FLEXA SERIES EXTENSION POLE, CLAMP BASE. 1 - OVERHEAD BIN, 48"W X 16"D, UPMOUNT. COLLABORATIVE TOOLBAR. 1 - PEDESTAL FIXED BOX/BOX/FILE, FLUSH STEEL FRONT, 2 - BOX DRAWERS W/ DIVIDER, FILE DRAWER ACCOMMODATES FRONT-TO-BACK LETTER-SIZE HANGING FILE, 22 5/8"D X 15"W X 27"H LOCKING, W/ COUNTERWEIGHT. 1 - PEDESTAL FIXED FILE/FILE, FLUSH STEEL FRONT, 2 - FILE DRAWERS ACCOMMODATE FRONT-TO-BACK LETTER-SIZE HANGING FILE, 28 5/8"D X 15"W X 27"H, LOCKING, W/ COUNTERWEIGHT.



Note - Finishes pictured may vary from item specified

Finish Images

SEE FOLLOWING PAGE

Location and Quantity

OPEN OFFICE 111: 4

Total Quantity: 4

Finish

Worksurface: Steelcase Laminate Solid in Milk 2884
 Metal Panel Trim: Merle
 Exterior Panel: Steelcase Laminate Woodgrain in Storm Noce 2HSN/2LSN
 Tack Fabric: Steelcase Classics Collection, Sprite in Linen 5548

GSA/BPA Contract: See Manufacturer's Source List for Manufacturer Contact Information

Sustainability:

BIFMA LEVEL 3, SCS INDOOR ADVANTAGE GOLD, HHI, DECLARE LABEL

Finish Images



HPL Top
Milk 2884



3mm Edge
Milk 6052



Storage Painted
Case & Drawers
Merle 7360
(Textured)

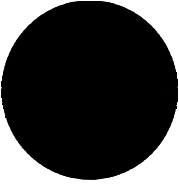

Lock Finish
Ember Chrome 9250



Fabric Panel Skin
Gr. A -Sprite Linen
5543



HPL Panel Skin
Storm Noce 2HSN



Markerboard Skin
Whiteboard 7076

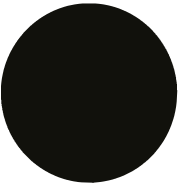

Monitor Arm
Black



FF&E Procurement Information

Item Description: 105W x 64D x 36H/48H U-SHAPED, PANEL-BASED WORKSTATION

Item Code: WS8b.A

Item Picture:

Manufacturer: STEELCASE

Dimensions: 105W X 64D X 36H/48H

Warranty: LIMITED LIFETIME

Salient Characteristics

48"H & 36H PANELS. PANELS ALONG DRYWALL TO HAVE BOTTOM 18" FABRIC TILE REMOVED ON BOTH SIDES FOR ACCESS TO WALL OUTLETS/CONDUIT. 30"D X 60"W STRAIGHT WORKSURFACE W/ 1/2" CORD DROP EDGE. 18.875"D X 48"W STRAIGHT WORKSURFACE W/ 1/2" CORD DROP EDGE. 24"D X 60"W STRAIGHT WORKSURFACE W/ 1/2" CORD DROP EDGE. 4 - FLEXA BUILD HEAVY DUTY MONITOR ARMS, EXTENSION ARM, POLE CLAMP. 2 FLEXA SERIES EXTENSION POLE, CLAMP BASE. 1 - OVERHEAD BIN, 48"W X 16"D, UPMOUNT. 1 - FIXED PEDESTAL BOX/BOX/FILE, ACCOMMODATES FRONT-TO-BACK LETTER-SIZE HANGING FILE, FLUSH STEEL FRONT, LOCKING, COUNTERWEIGHT, 28 5/8"D X 15"W X 27"H. 1 - FIXED PEDESTAL FILE/FILE, ACCOMMODATES FRONT-TO-BACK LETTER-SIZE HANGING FILE, FLUSH STEEL FRONT, LOCKING, COUNTERWEIGHT, 28 5/8"D X 15"W X 27"H.

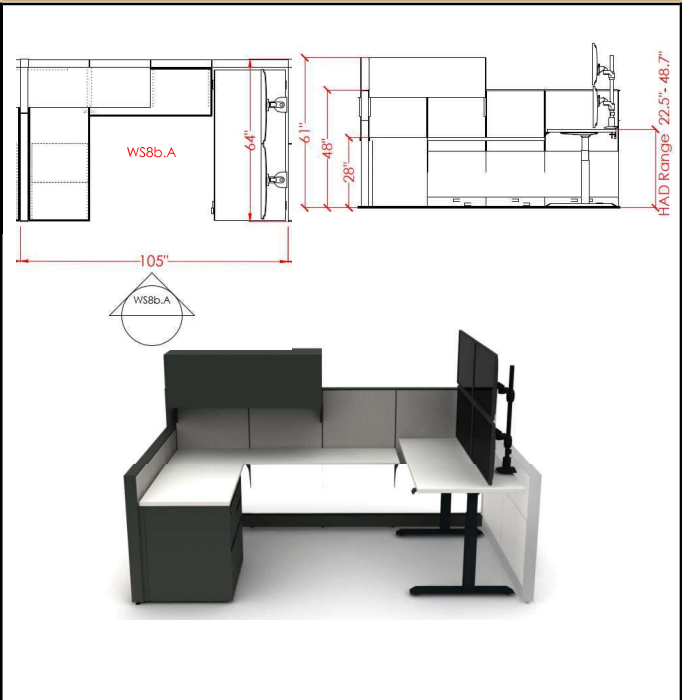

Finish Images

SEE FOLLOWING PAGE

Note - Finishes pictured may vary from item specified

Location and Quantity

OPEN OFFICE 111: 4

Total Quantity: 4

Finish

Worksurface: Steelcase Laminate Solid in Milk 2884 Metal Panel Trim: Merle Exterior Panel: Steelcase Laminate Wo

GSA/BPA Contract: See Manufacturer's Source List for Manufacturer Contact Information

Sustainability:

BIFMA LEVEL 3, SCS INDOOR ADVANTAGE GOLD, HHI, DECLARE LABEL

Finish Images



HPL Top
Milk 2884



3mm Edge
Milk 6052



Storage Painted
Case & Drawers
Merle 7360
(Textured)



Lock Finish
Ember Chrome 9250



Fabric Panel Skin
Gr. A -Sprite Linen
5543



Monitor Arm
Matte Black



FF&E Procurement Information

Item Description: 126W x 81D x 36H/48H U-SHAPED, PANEL-BASED WORKSTATION

Item Code: WS9a.A

Item Picture:

Manufacturer: STEELCASE

Dimensions: 126W X 81D X 36H/48H

Warranty: LIMITED LIFETIME

Salient Characteristics

48"H & 36H PANELS. PANELS ALONG DRYWALL TO HAVE BOTTOM 18" FABRIC TILE REMOVED ON BOTH SIDES FOR ACCESS TO WALL OUTLETS/CONDUIT. 30"D X 78"W STRAIGHT WORKSURFACE W/ 1/2" CORD DROP EDGE. 18.875"D X 66"W STRAIGHT WORKSURFACE W/ 1/2" CORD DROP EDGE. 24"D X 60"W STRAIGHT WORKSURFACE W/ 1/2" CORD DROP EDGE. 4 - FLEXA BUILD HEAVY DUTY MONITOR ARMS, EXTENSION ARM, POLE CLAMP. 2 FLEXA SERIES EXTENSION POLE, CLAMP BASE. 1 - OVERHEAD BIN, 60"W X 16"D, UPMOUNT. 1 - FIXED PEDESTAL BOX/BOX/FILE, ACCOMMODATES FRONT-TO-BACK LETTER-SIZE HANGING FILE, FLUSH STEEL FRONT, LOCKING, COUNTERWEIGHT, 28 5/8"D X 15"W X 27"H. 1 - FIXED PEDESTAL FILE/FILE, ACCOMMODATES FRONT-TO-BACK LETTER-SIZE HANGING FILE, FLUSH STEEL FRONT, LOCKING, COUNTERWEIGHT, 28 5/8" 24" D X 15"W X 27"H. 1 - **MOBILE PEDESTAL BOX/FILE, ACCOMMODATES FRONT-TO-BACK LETTER-SIZE HANGING FILE, FLUSH STEEL FRONT, LOCKING, COUNTERWEIGHT, 28 5/8" D X 15"W X 27"H.**

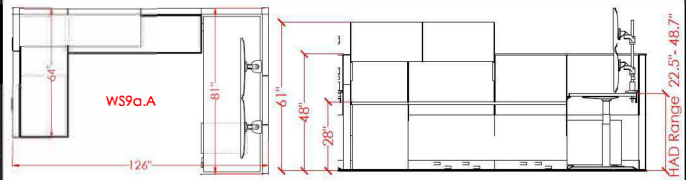

Finish Images

SEE FOLLOWING PAGE

Note - Finishes pictured may vary from item specified

Location and Quantity

OPEN OFFICE 111: 1

Total Quantity: 1

Finish

Worksurface: Steelcase Laminate Solid in Milk 2884
 Metal Panel Trim: Merle
 Exterior Panel: Steelcase Laminate Woodgrain in Storm Noce 2HSN/2LSN
 Tack Fabric: Steelcase Classics Collection, Sprite in Linen 5548

GSABPA Contract: See Manufacturer's Source List for Manufacturer Contact Information

Sustainability:

BIFMA LEVEL 3, SCS INDOOR ADVANTAGE GOLD, HHI, DECLARE LABEL

Finish Images



HPL Top
Milk 2884



3mm Edge
Milk 6052



Storage Painted
Case & Drawers
Merle 7360
(Textured)



Lock Finish
Ember Chrome 9250



Fabric Panel Skin
Gr. A -Sprite Linen
5543



Monitor Arm
Matte Black



FF&E Procurement Information

Item Description: 126W x 84D x 36H/48H U-SHAPED, PANEL-BASED WORKSTATION

Item Code: WS9b.A

Item Picture:

Manufacturer: STEELCASE

Dimensions: 126W X 84D X 36H/48H

Warranty: LIMITED LIFETIME

Salient Characteristics

48"H & 36H PANELS. PANELS ALONG DRYWALL TO HAVE BOTTOM 18" FABRIC TILE REMOVED ON BOTH SIDES FOR ACCESS TO WALL OUTLETS/CONDUIT. 30"D X 78"W STRAIGHT WORKSURFACE W/ 1/2" CORD DROP EDGE. 18.875"D X 66"W STRAIGHT WORKSURFACE W/ 1/2" CORD DROP EDGE. 24"D X 60"W STRAIGHT WORKSURFACE W/ 1/2" CORD DROP EDGE. 4 - FLEXA BUILD HEAVY DUTY MONITOR ARMS, EXTENSION ARM, POLE CLAMP. 2 FLEXA SERIES EXTENSION POLE, CLAMP BASE. 1 - OVERHEAD BIN, 60"W X 16"D, UPMOUNT. 1 - FIXED PEDESTAL BOX/BOX/FILE, ACCOMMODATES FRONT-TO-BACK LETTER-SIZE HANGING FILE, FLUSH STEEL FRONT, LOCKING, COUNTERWEIGHT, 28 5/8"D X 15"W X 27"H. 1 - FIXED PEDESTAL FILE/FILE, ACCOMMODATES FRONT-TO-BACK LETTER-SIZE HANGING FILE, FLUSH STEEL FRONT, LOCKING, COUNTERWEIGHT, 28 5/8" 24"D X 15"W X 27"H. 1 - MOBILE PEDESTAL BOX/FILE, ACCOMMODATES FRONT-TO-BACK LETTER-SIZE HANGING FILE, FLUSH STEEL FRONT, LOCKING, COUNTERWEIGHT, 28 5/8"D X 15"W X 20"H.

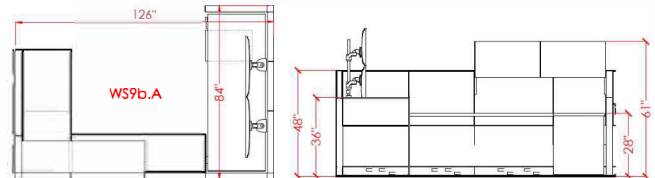

Note - Finishes pictured may vary from item specified

Location and Quantity

OPEN OFFICE 111: 1

Total Quantity: 1

Finish Images

SEE FOLLOWING PAGE

Finish

Worksurface: Steelcase Laminate Solid in Milk 2884 Metal Panel Trim: Merle Exterior Panel: Steelcase Laminate Wo

GSA/BPA Contract: See Manufacturer's Source List for Manufacturer Contact Information

Sustainability:

BIFMA LEVEL 3, SCS INDOOR ADVANTAGE GOLD, HHI, DECLARE LABEL

Finish Images



HPL Top
Milk 2884



3mm Edge
Milk 6052



Storage Painted
Case & Drawers
Merle 7360
(Textured)



Lock Finish
Ember Chrome 9250



Fabric Panel Skin
Gr. A -Sprite Linen
5543



Monitor Arm
Matte Black



FF&E Procurement Information

Item Description: 90W x 54D x 60H U-SHAPE, PANEL-BASED WORKSTATION

Item Code: WS10a.A

Item Picture:

Manufacturer: STEELCASE



Dimensions: 90W x 54D x 60H

Warranty: LIMITED LIFETIME

Salient Characteristics

3 - 60"H PANELS. PANELS ALONG DRYWALL TO HAVE BOTTOM 18" FABRIC TILE REMOVED ON BOTH SIDES FOR ACCESS TO WALL OUTLETS/CONDUIT. FABRIC INTERIOR, LAMINATE EXTERIOR AT AISLES. WING PANEL ALONG AISLE, 18"H LAMINATE SKIN & 36"H MARKERBOARD SKIN W/ MARKERBOARD KIT/TOOLBAR. 23"D X 76"W MIGRATION SE, T-LEG, EXTENDED HEIGHT, UP/DOWN CONTROLLER NA 120V, NEMA 1-15 TYPE A-D. 24"D X 84"W STRAIGHT WORKSURFACE W/ 1/2" CORD DROP EDGE. 2 - 18"D X 24W STRAIGHT WORKSURFACE W/ 1/2" CORD DROP EDGE. 4 - FLEXA BUILD HEAVY DUTY MONITOR ARMS, EXTENSION ARM, POLE CLAMP. 2 FLEXA SERIES EXTENSION POLE, CLAMP BASE. 2 - OVERHEAD BIN, 24"W X 16"D. 1- LETTER TRAY LANDSCAPE. 1 - FIXED PEDESTAL BOX/BOX/FILE, ACCOMMODATES FRONT-TO-BACK LETTER-SIZE HANGING FILE, FLUSH STEEL FRONT, LOCKING, COUNTERWEIGHT, 28 5/8"D X 15"W X 27"H. 1 - FIXED PEDESTAL FILE/FILE, ACCOMMODATES FRONT-TO-BACK LETTER-SIZE HANGING FILE, FLUSH STEEL FRONT, LOCKING, COUNTERWEIGHT, 28 5/8" 18"D X 15"W X 27"H.



Finish Images

SEE FOLLOWING PAGE

Note - Finishes pictured may vary from item specified

Location and Quantity

OPEN OFFICE 111:1

Total Quantity: 1

Finish

Worksurface: Steelcase Laminate Solid in Milk 2884
 Metal Panel Trim: Merle
 Exterior Panel: Steelcase Laminate Woodgrain in Storm Noce 2HSN/2LSN
 Tack Fabric: Steelcase Classics Collection, Sprite in Linen 5548

GSA/BPA Contract: See Manufacturer's Source List for Manufacturer Contact Information

Sustainability:

BIFMA LEVEL 3, SCS INDOOR ADVANTAGE GOLD, HHI, DECLARE LABEL

Finish Images



HPL Top
Milk 2884



3mm Edge
Milk 6052



Storage Painted
Case & Drawers
Merle 7360
(Textured)

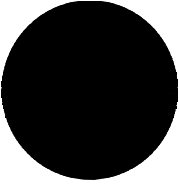

Lock Finish
Ember Chrome 9250



Fabric Panel Skin
Gr. A -Sprite Linen
5543



HPL Panel Skin
Storm Noce 2HSN



Markerboard Skin
Whiteboard 7076

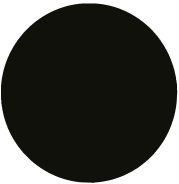

Monitor Arm
Black



FF&E Procurement Information

Item Description: 87W x 54D x 60H U-SHAPE, PANEL-BASED WORKSTATION

Item Code: WS10b.A

Item Picture:

Manufacturer: STEELCASE

Dimensions: 87W x 54D x 60H
Warranty: LIMITED LIFETIME

Salient Characteristics

3 - 60"H PANELS. PANELS ALONG DRYWALL TO HAVE BOTTOM 18" FABRIC TILE REMOVED ON BOTH SIDES FOR ACCESS TO WALL OUTLETS/CONDUIT. 24"D X 84"W STRAIGHT WORKSURFACE W/ 1/2" CORD DROP EDGE. 2 - 18"D X 24"W STRAIGHT WORKSURFACE W/ 1/2" CORD DROP EDGE.
 4 - FLEXA BUILD HEAVY DUTY MONITOR ARMS, EXTENSION ARM, POLE CLAMP. 2 FLEXA SERIES EXTENSION POLE, CLAMP BASE. 2 - OVERHEAD BIN, 24"W X 16"D. 1 - FIXED PEDESTAL BOX/BOX/FILE, ACCOMMODATES FRONT-TO-BACK LETTER-SIZE HANGING FILE, FLUSH STEEL FRONT, LOCKING, COUNTERWEIGHT, 28 5/8"D X 15"W X 27"H. 1 - FIXED PEDESTAL FILE/FILE, ACCOMMODATES FRONT-TO-BACK LETTER-SIZE HANGING FILE, FLUSH STEEL FRONT, LOCKING, COUNTERWEIGHT, 28-5/8" 18"D X 15"W X 27"H.

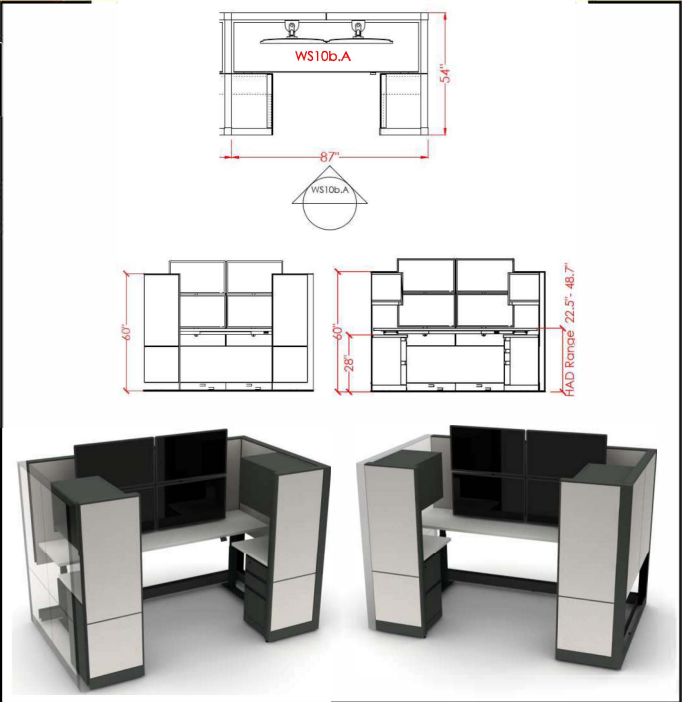

Finish Images

SEE FOLLOWING PAGE

Note - Finishes pictured may vary from item specified

Location and Quantity

OPEN OFFICE 111: 4

Total Quantity: 4

Finish

Worksurface: Steelcase Laminate Solid in Milk 2884Metal Panel Trim: MerleExterior Panel: Steelcase Laminate Wo

GSA/BPA Contract: See Manufacturer's Source List for Manufacturer Contact Information

Sustainability:

BIFMA LEVEL 3, SCS INDOOR ADVANTAGE GOLD, HHI, DECLARE LABEL

Finish Images



HPL Top
Milk 2884



3mm Edge
Milk 6052



Storage Painted
Case & Drawers
Merle 7360
(Textured)



Lock Finish
Ember Chrome 9250



Fabric Panel Skin
Gr. A -Sprite Linen
5543



Monitor Arm
Matte Black



FF&E Procurement Information

Item Description: 90W x 76D x 60H L-SHAPED, PANEL-BASED WORKSTATION

Item Code: WS11a.A

Item Picture:

Manufacturer: STEELCASE

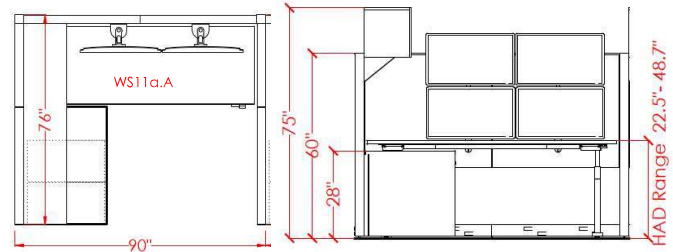

Dimensions: 90W X 76D X 60H

Warranty: LIMITED LIFETIME

Salient Characteristics

3 - 60"H PANELS. PANELS ALONG DRYWALL TO HAVE BOTTOM 18" FABRIC TILE REMOVED ON BOTH SIDES FOR ACCESS TO WALL OUTLETS/CONDUIT. 30"D X 84"W STRAIGHT WORKSURFACE W/ 1/2" CORD DROP EDGE. 30"D X 42"W STRAIGHT WORKSURFACE W/ 1/2" CORD DROP EDGE. 4 - FLEXA BUILD HEAVY DUTY MONITOR ARMS, EXTENSION ARM, POLE CLAMP. 1 - OVERHEAD BIN, 72"W X 16"D. 1 - FIXED PEDESTAL BOX/BOX/FILE, ACCOMMODATES FRONT-TO-BACK LETTER-SIZE HANGING FILE, FLUSH STEEL FRONT, LOCKING, COUNTERWEIGHT, 28 5/8"D X 15"W X 27"H. 1 - FIXED PEDESTAL FILE/FILE, ACCOMMODATES FRONT-TO-BACK LETTER-SIZE HANGING FILE, FLUSH STEEL FRONT, LOCKING, COUNTERWEIGHT, 28 5/8"D X 15"W X 27"H.



Finish Images

Note - Finishes pictured may vary from item specified

SEE FOLLOWING PAGE

Location and Quantity

OPEN OFFICE 129: 1

Total Quantity: 1

Finish

Worksurface: Steelcase Laminate Solid in Milk 2884
 Metal Panel Trim: Merle
 Exterior Panel: Steelcase Laminate Woodgrain in Storm Noce 2HSN/2LSN
 Tack Fabric: Steelcase Classics Collection, Sprite in Linen 5548

GSA/BPA Contract: See Manufacturer's Source List for Manufacturer Contact Information

Sustainability:

BIFMA LEVEL 3, SCS INDOOR ADVANTAGE GOLD, HHI, DECLARE LABEL

Finish Images



HPL Top
Milk 2884



3mm Edge
Milk 6052



Storage Painted
Case & Drawers
Merle 7360
(Textured)



Lock Finish
Ember Chrome 9250



Fabric Panel Skin
Gr. A -Sprite Linen
5543



Monitor Arm
Matte Black



FF&E Procurement Information

Item Description: 84W x 76D x 60H L-SHAPED, PANEL-BASED WORKSTATION

Item Code: WS11b.A

Item Picture:

Manufacturer: STEELCASE

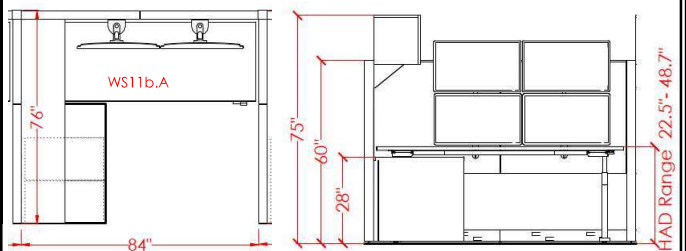

Dimensions: 84W X 76D X 60H

Warranty: LIMITED LIFETIME

Salient Characteristics

3 - 60"H PANELS. PANELS ALONG DRYWALL TO HAVE BOTTOM 18" FABRIC TILE REMOVED ON BOTH SIDES FOR ACCESS TO WALL OUTLETS/CONDUIT. 30"D X 84"W STRAIGHT WORKSURFACE W/ 1/2" CORD DROP EDGE. 30"D X 42"W STRAIGHT WORKSURFACE W/ 1/2" CORD DROP EDGE. 4 - FLEXA BUILD HEAVY DUTY MONITOR ARMS, EXTENSION ARM, POLE CLAMP. 1 - OVERHEAD BIN, 72"W X 16"D. 1 - FIXED PEDESTAL BOX/BOX/FILE, ACCOMMODATES FRONT-TO-BACK LETTER-SIZE HANGING FILE, FLUSH STEEL FRONT, LOCKING, COUNTERWEIGHT, 28 5/8"D X 15"W X 27"H. 1 - FIXED PEDESTAL FILE/FILE, ACCOMMODATES FRONT-TO-BACK LETTER-SIZE HANGING FILE, FLUSH STEEL FRONT, LOCKING, COUNTERWEIGHT, 28 5/8"D X 15"W X 27"H.



Finish Images

Note - Finishes pictured may vary from item specified

SEE FOLLOWING PAGE

Location and Quantity

OPEN OFFICE 129: 1

Total Quantity: 1

Finish

Worksurface: Steelcase Laminate Solid in Milk 2884Metal Panel Trim: MerleExterior Panel: Steelcase Laminate Wo

GSA/BPA Contract: See Manufacturer's Source List for Manufacturer Contact Information

Sustainability:

BIFMA LEVEL 3, SCS INDOOR ADVANTAGE GOLD, HHI, DECLARE LABEL

Finish Images



HPL Top
Milk 2884



3mm Edge
Milk 6052



Storage Painted
Case & Drawers
Merle 7360
(Textured)



Lock Finish
Ember Chrome 9250



Fabric Panel Skin
Gr. A -Sprite Linen
5543



Monitor Arm
Matte Black



FF&E Procurement Information

Item Description: 90W x 76D x 60H L-SHAPED, PANEL-BASED WORKSTATION

Item Code: WS11c.A

Item Picture:

Manufacturer: STEELCASE

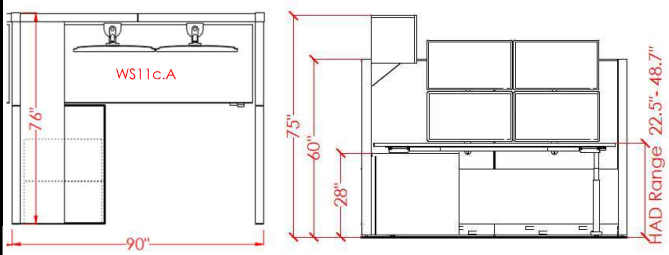

Dimensions: 90W X 76D X 60H

Warranty: LIMITED LIFETIME

Salient Characteristics

3 - 60"H PANELS. PANELS ALONG DRYWALL TO HAVE BOTTOM 18" FABRIC TILE REMOVED ON BOTH SIDES FOR ACCESS TO WALL OUTLETS/CONDUIT. 30"D X 84"W STRAIGHT WORKSURFACE W/ 1/2" CORD DROP EDGE. 30"D X 42"W STRAIGHT WORKSURFACE W/ 1/2" CORD DROP EDGE. 4 - FLEXA BUILD HEAVY DUTY MONITOR ARMS, EXTENSION ARM, POLE CLAMP. 1 - OVERHEAD BIN, 72"W X 16"D. 1 - FIXED PEDESTAL BOX/BOX/FILE, ACCOMMODATES FRONT-TO-BACK LETTER-SIZE HANGING FILE, FLUSH STEEL FRONT, LOCKING, COUNTERWEIGHT, 28 5/8"D X 15"W X 27"H. 1 - FIXED PEDESTAL FILE/FILE, ACCOMMODATES FRONT-TO-BACK LETTER-SIZE HANGING FILE, FLUSH STEEL FRONT, LOCKING, COUNTERWEIGHT, 28 5/8"D X 15"W X 27"H.



Finish Images

SEE FOLLOWING PAGE

Note - Finishes pictured may vary from item specified

Location and Quantity

OPEN OFFICE 129: 1

Total Quantity: 1

Finish

Worksurface: Steelcase Laminate Solid in Milk 2884Metal Panel Trim: MerleExterior Panel: Steelcase Laminate Wo

GSA/BPA Contract: See Manufacturer's Source List for Manufacturer Contact Information

Sustainability:

BIFMA LEVEL 3, SCS INDOOR ADVANTAGE GOLD, HHI, DECLARE LABEL

Finish Images



HPL Top
Milk 2884



3mm Edge
Milk 6052



Storage Painted
Case & Drawers
Merle 7360
(Textured)



Lock Finish
Ember Chrome 9250



Fabric Panel Skin
Gr. A -Sprite Linen
5543



Monitor Arm
Matte Black



FF&E Procurement Information

Item Description: 90W x 76D x 48H L-SHAPED, PANEL-BASED WORKSTATION

Item Code: WS11d.A

Item Picture:

Manufacturer: STEELCASE

Dimensions: 90W X 76D X 48H

Warranty: LIMITED LIFETIME

Salient Characteristics

3 - 48"H PANELS. PANELS ALONG DRYWALL TO HAVE BOTTOM 18" FABRIC TILE REMOVED ON BOTH SIDES FOR ACCESS TO WALL OUTLETS/CONDUIT. FABRIC INTERIOR, LAMINATE EXTERIOR AT AISLES. WING PANEL ALONG AISLE, 18"H LAMINATE SKIN & 24"H MARKERBOARD SKIN W/ MARKERBOARD KIT/TOOLBAR. 30"D X 72"W STRAIGHT WORKSURFACE W/ 1/2" CORD DROP EDGE. 28"D X 52"W MIGRATION SE, T-LEG, EXTENDED HEIGHT, UP/DOWN CONTROLLER/ NEMA 1-15 TYPE A-D. 4 - FLEXA BUILD HEAVY DUTY MONITOR ARMS, EXTENSION ARM, POLE CLAMP. 2 FLEXA SERIES EXTENSION POLE, CLAMP BASE. 1 - OVERHEAD BIN, 72"W X 16"D UNDERMOUNT. 1 - FIXED PEDESTAL BOX/BOX/FILE, ACCOMMODATES FRONT-TO-BACK LETTER-SIZE HANGING FILE, COUNTERWEIGHT, 28 5/8"D X 15"W X 27"H. 1 - FIXED PEDESTAL FILE/FILE, ACCOMMODATES FRONT-TO-BACK LETTER-SIZE HANGING FILE, FLUSH STEEL FRONT, LOCKING, COUNTERWEIGHT, 28 5/8"D X 15"W X 27"H.

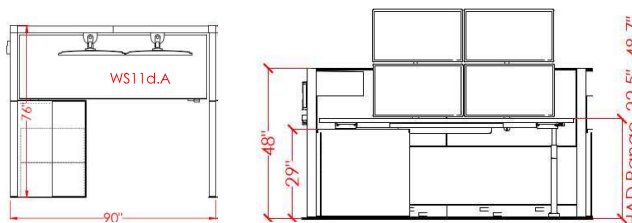

Finish Images

SEE FOLLOWING PAGE

Note - Finishes pictured may vary from item specified

Location and Quantity

OPEN OFFICE 129: 2

Total Quantity: 2

Finish

Worksurface: Steelcase Laminate Solid in Milk 2884Metal Panel Trim: MerleExterior Panel: Steelcase Laminate Wo

GSA/BPA Contract: See Manufacturer's Source List for Manufacturer Contact Information

Sustainability:

BIFMA LEVEL 3, SCS INDOOR ADVANTAGE GOLD, HHI, DECLARE LABEL

Finish Images



HPL Top
Milk 2884



3mm Edge
Milk 6052



HAD Base, Storage
Painted Case &
Drawers
Merle 7360
(Textured)

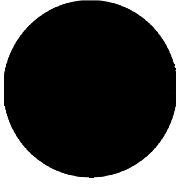

Lock Finish
Ember Chrome 9250

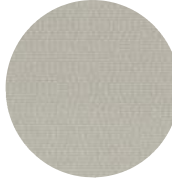

Fabric Panel Skin
Gr. A -Sprite Linen
5543



HPL Panel Skin
Storm Noce 2HSN



Markerboard Skin
Whiteboard 7076

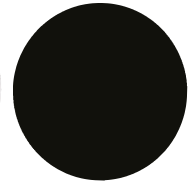

Monitor Arm
Black



LRSO HARDWARE/SOFTWARE DEVELOPMENT & TEST FACILITY
 EGLIN AFB, FLORIDA

Black & Veatch Special Projects
 100% Submittal, September 2024

FF&E Procurement Information

Item Description: 84W x 76D x 48H L-SHAPED, PANEL-BASED WORKSTATION

Item Code: WS11e.A

Item Picture:

Manufacturer: STEELCASE

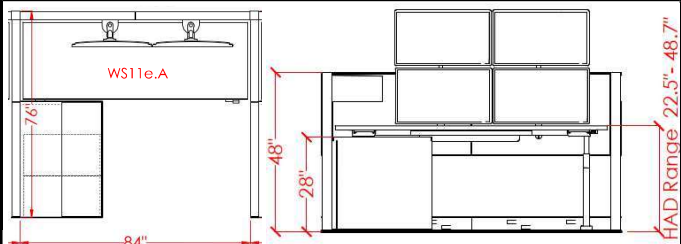

Dimensions: 84W X 76D X 48H

Warranty: LIMITED LIFETIME

Salient Characteristics

3 - 48"H PANELS. PANELS ALONG DRYWALL TO HAVE BOTTOM 18" FABRIC TILE REMOVED ON BOTH SIDES FOR ACCESS TO WALL OUTLETS/CONDUIT. 30"D X 84"W STRAIGHT WORKSURFACE W/ 1/2" CORD DROP EDGE. 30"D X 42"W STRAIGHT WORKSURFACE W/ 1/2" CORD DROP EDGE. 4 - FLEXA BUILD HEAVY DUTY MONITOR ARMS, EXTENSION ARM, POLE CLAMP. 2 FLEXA SERIES EXTENSION POLE, CLAMP BASE. 1 - OVERHEAD BIN, 72"W X 16"D UPMOUNT. 1 - FIXED PEDESTAL BOX/BOX/FILE, ACCOMMODATES FRONT-TO-BACK LETTER-SIZE HANGING FILE, FLUSH STEEL FRONT, LOCKING, COUNTERWEIGHT, 28 5/8"D X 15"W X 27"H. 1 - FIXED PEDESTAL FILE/FILE, ACCOMMODATES FRONT-TO-BACK LETTER-SIZE HANGING FILE, FLUSH STEEL FRONT, LOCKING, COUNTERWEIGHT, 28 5/8"D X 15"W X 27"H.



Finish Images

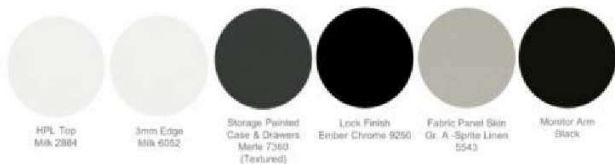

Note - Finishes pictured may vary from item specified

Location and Quantity

OPEN OFFICE 129: 2

Total Quantity: 2

Finish

Worksurface: Steelcase Laminate Solid in Milk 2884
 Metal Panel Trim: Merle
 Exterior Panel: Steelcase Laminate Woodgrain in Storm Noce 2HSN/2LSN
 Tack Fabric: Steelcase Classics Collection, Sprite in Linen 5548

GSA/BPA Contract: See Manufacturer's Source List for Manufacturer Contact Information

Sustainability:

BIFMA LEVEL 3, SCS INDOOR ADVANTAGE GOLD, HHI, DECLARE LABEL

WORKSTATIONS WS1 – WS11e: FLEXA MONITOR ARMS

- ADDITIONAL INFORMATION



Supports monitors up to 44 lb (20 kg)

- Heavy-duty arm for the Flexa Build Monitor System supporting up to 44 lb (20 kg).
- All the same features and benefits of the 500FFL100 but allowing the user more weight per arm.
- Flexa is our most versatile monitor system.
- The articulated arm adds extra flexibility to accommodate most situations and spaces.
- You can mix and match all the components to achieve the perfect solution from single to quad monitor configurations.
- Monitor mount swivel left to right: 90° to -90°
- Space-saving design to free up and gain additional desktop workspace
- 90° monitor rotation
- Tilts up and down
- Freely adjusting height for an optimal ergonomic position
- Built-in cable management for an organized and neat workspace
- VESA compatible: 75 x 75, 100 x 100
- Black Finish

Flexa Build Heavy-Duty Monitor Arm



Fixed Extension Arm for larger monitors



Extension pole



Clamp mount



FF&E Procurement Information

Item Description: 72W x 30D x 29H STRAIGHT WORKSTATION

Item Code: WS12

Item Picture:

Manufacturer: STEELCASE

Dimensions: 72W X 30D X 29H

Warranty: LIMITED LIFETIME

Salient Characteristics

30D x 72W STRAIGHT WORKSURFACE WITH BRACE AND PLINTH BASE END PANELS. 6 - FLEXA BUILD HEAVY DUTY MONITOR ARM, EXTENSION ARM, POLE CLAMP. 3 - FLEXA SERIES EXTENSION POLE, CLAMP BASE. 1 - PEDESTAL - FIXED, BOX/BOX/FILE, LAMINATE FRONT, LOCKING, 23.25"D x 15"W x 27.5"H WITH COUNTERWEIGHT.

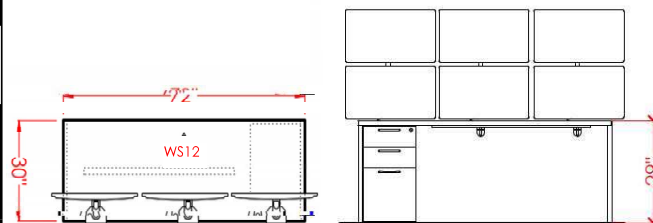

Note - Finishes pictured may vary from item specified

Location and Quantity

LAB 1 CONTROL: 6
 LAB 2 CONTROL: 6

Total Quantity: 12

Finish Images

SEE FOLLOWING PAGE

Finish

Worksurface: MILK HPL 2884 W/ MILK 6052 EDGE BAND
 Storage: MERLE 2HMG
 Monitor Arm: BLACK

GSA/BPA Contract: See Manufacturer's Source List for Manufacturer Contact Information

Sustainability:

N/A

Finish Images



HPL Top
Milk 2884



3mm Edge
Milk 6052



Storage Laminate,
End Panels
Merle 2HMG (HPL)

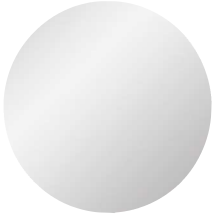

Contemporary Pull &
Lock
Polished Chrome
9201

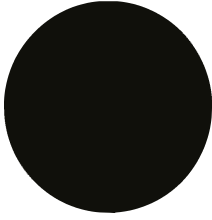

Monitor Arm
Black

APPENDIX E
CONSTRUCTION SECURITY PLAN
(CSP)

UNCLASSIFIED

AFNWC/NDB

Hardware Software Integration Facility

SCIF ID TBD

Construction Security Plan (CSP)

19 May 2025

REVISION NUMBER (as appropriate)

AFMC Overprint

Classification Instructions
As appropriate

UNCLASSIFIED

Table of Contents

Purpose

References

Project Description

Releasable Statement

Risk Management

Construction Security Process

Control of Operations if a Renovation Project

Security Administration

Historical Records

Revision Process

Appendix A – Acronyms

Appendix B – Definitions

Appendix C – Prohibited Countries List Matrix

(U) PURPOSE:

The purpose of this project is to construct a dedicated secure laboratory to support the United States Air Force (USAF) Air Force Nuclear Weapons Center (AFNWC) missions for the Air Force Global Strike Command (AFGSC) at Eglin Air Force Base (AFB). This facility will provide multiple laboratory and administrative spaces to conduct hardware and software research and development, testing, evaluation, and validation of AFNWC and AFGSC advanced subsystems. This laboratory is essential to providing hardware validation and software certification for immediate and future fielding to the warfighter. This integration and technology maturation support is critical to fielding advanced programs for national security and SAF/AQ Priority Programs. This facility will be designed to support 24-hour operations when required. The facility will meet ICD/ICS 705 v1.5.1 standards for Sensitive Compartmented Information Facilities. The entire space will be a CUA, no CA is required for this project.

1.1 The proposed CSP outlines the security protective measures that will be applied throughout all phases of the construction project. The requirements set forth in this plan provide the baseline for construction security activities and may be supplemented as required but may not be reduced without coordination and approval from the Accrediting Official (AO).

1.2 This CSP constitutes a working living document that will be regularly reviewed and updated as required to reflect changing conditions and the current status of the project until the facility has been granted an accreditation (physical and TEMPEST).

1.3 The CSP will be resubmitted to the AO for a re-approval when updates to the previously submitted are required. Updates will be identified with an asterisk at the beginning of the paragraph.

2. REFERENCES:

2.1. ICD 503, Intelligence Community Information Technology Systems Security Risk Management, Certification and Accreditation, Dated: 15 September 2008

2.2. ICD 700, Protection of National Intelligence, Dated: 7 June 2012

2.3. ICD 704, Personnel Security Standards and Procedures Governing Eligibility for Access to Sensitive Compartmented Information and Other Controlled Access Program Information, Dated: 1 October 2008

2.4. ICPG 704.1, Personnel Security Investigative Standards and Procedures Governing Eligibility for Access to Sensitive Compartmented Information and Other Controlled Access Program Information, Dated: 2 October 2008

- 2.5. ICPG 704.3, Denials or Revocation of Access to Sensitive Compartmented Information, Other Controlled Access Program Information, and Appeals Processes, Dated: 2 October 2008
- 2.6. ICPG 704.4, Reciprocity of Personnel Security Clearance and Access Determinations, Dated: 2 October 2008
- 2.7. ICPG 704.5, Intelligence Community Personnel Security Database Scattered Castles, Dated: 2 October 2008
- 2.8. ICPG 704.6, Conduct of Polygraph Examinations for Personnel Security Vetting, Dated: 4 February 2015
- 2.9. ICD 705, Sensitive Compartmented Information Facilities, Dated: 26 May 2010
- 2.10. ICS 705-01, Physical and Technical Security Standards for Sensitive Compartmented Information Facilities, Dated 17 September 2010
- 2.11. ICS 705-02, Standards for the Accreditation and Reciprocal Use of Sensitive Compartmented Information Facilities, Dated: 28 March 2022
- 2.13. IC Tech Spec-for ICD/ICS 705, Version 1.5.1, Technical Specifications for Construction and Management of Sensitive Compartmented Information Facilities, Dated: 26 July 2021
- 2.14. DoDM 5105.21 V1 – V3, Sensitive Compartmented Information Administrative Security Manual, Dated: 19 October 2012
- 2.15. DoDD 5205.16, The DoD Insider Threat Program, Dated: 14 September 2014
- 2.16. ICD 731, Supply Chain Risk Management, Dated: 7 December 2013
- 2.17. ICS 731-02, Supply Chain Threat Assessments, Dated: 25 September 2019
- 2.18. ICS 731-03, Supply Chain Information Sharing, Dated 29 June 2017
- 2.19. ICS 731-03, Annex A, Supply Chain Information Sharing Implementation
- 2.20. ICS 731-04, Supply Chain Vulnerability Assessments, Dated: 17 July 2019
- 2.21. ICS 731-05, Supply Chain Risk Assessments, Dated: 17 July 2019
- 2.22. CNSSAM TEMPEST/1-13, RED/BLACK Installation Guidance, Dated: 17 January 2014
- 2.23. CNSSI No. 5000, Voice Over Internet Protocol (VOIP) Telephony, Dated: 2 August 2021
- 2.24. CNSSI No. 5002, Telephony Isolation Used for Unified Communications Implementations Within Physically Protected Spaces, Dated: 18 December 2019

2.25. CNSSI No. 5006, National Instruction for Approved Telephone Equipment, Dated: September 2011 – TSG 6 Approved Equipment List (AEL) Spreadsheet, Dated: October 2022

2.26. CNSSI No. 7003, Protected Distribution Systems (PDS), Dated: September 2015

3. PROJECT DESCRIPTION:

3.1. Project Summary:

No contract award will initiate without DIA's approval to proceed.

Phase I shall begin when US Army Corps of Engineers (USACE) awards the construction contract. The only work that may be performed during Phase 1 is the sitework/earthwork, and security infrastructure delivery/installation/set up (e.g., fence, Access Control Facility (ACF), Secure Storage Area (SSA), etc.). Phase 1 will require security oversight at a reduced level of Phase 2. Facility construction is not authorized to be performed in any way; however, orders may be placed for 'long lead' procurement items at the discretion of the General Contractor (GC).

Phase 2 shall begin when all security infrastructure has been delivered, installed, set up, and approved by the Site Security Manager (SSM) as acceptable. The GC shall officially request a site review/inspection to the SSM no less than three (3) business days in advance to confirm the SCS and SSA is secure. If confirmed/approved, the SSM shall notify USACE, and USACE may issue Phase 2 to the GC. At the start of Phase 2, all aspects of this CSP shall be enforced in full and without exception. Questions on Phase 1 and Phase 2 authorized work shall be directed to the SSM and USACE.

SCIF is required to designed constructed to be compliant with Fire Code National Fire Protection Association 1, Life Safety Code NFPA 101, The Americans with Disabilities Act 28 CFR Part 36, and the Uniform Federal Accessibilities standard where applicable

Exterior Wall System: The exterior wall system will be loadbearing metal stud construction. The exterior wall design is similar to the exterior design of nearby buildings in this area of Eglin AFB.

The base of the wall will be constructed using cast stone units (24" wide X 12" high) to a height of 3-4" above finished floor level. Above this level, the exterior expression will consist of modular brick with ½" inset courses at approx. 2.0" (14 courses) O.C. vertically. These inset bands will give a subtle appearance similar to the quoins on other buildings in the area.

The wall system, from the outface to interior side, will include the 3 5/8" masonry veneer, a 2" air space, 2" polystyrene insulation, a membrane air barrier on DensGlass sheathing. The sheathing will be mechanically attached to the 6" load-bearing metal

stud system. The structural metal stud system will include 6" batt insulation, with 5/8" gypsum wallboard at the interior side. RF shielding will be included in the exterior walls, stopping at the corner of the collateral space, on the front side of the building, then picking back up at the office area, on the front side of the building, and continuing on.

Note: RF shielding will be on all 6 sides of the SCIF area. This will include the ceiling space in the SCIF area, the floor in the SCIF area, and the outside boundary of the SCIF. The internal walls, for instance the wall between the Security office and the Large Conference room, that wall will not have to be RF shielded. This only applies to the exterior walls that would be facing the area outside of the SCIF.

Exterior Doors and Frames: All exterior doors will be insulated, maximum duty hollow metal doors and frames to meet the SC-45 or STC-50, hot-dip zinc-coated steel with factory-primed finish, per ANSI/SDI A250.8, with RF shielding as needed. Doors and frames in the RF-shielded boundary perimeter will be RF-shielded and STC-50 rated. Hinge pins will be located on the inside of the area. All exterior doors will have a paint finish, no glazing. Door frames will be welded, painted, and grout filled. Main entrance door will be equipped with an electronic card reader for access by authorized personnel. Emergency exit doors will have panic bars and will be alarmed to detect unauthorized opening. An intrusion detection system (IDS) will be provided at all doors.

Interior Doors and Frames: All interior hollow metal doors and frames will be painted. Solid core wood doors will be pre-finished transparent stained finish. No glass lights or sidelights will be provided. Doors will meet the SC-45 or STC-50 rating, to match the STC rating of the wall. Doors and frames in the RF-shielded boundary perimeter will be RF-shielded and STC-50 rated. Hinge pins will be located on the inside of the area. Doors will have x10 locks, card readers, and additional hardware for access by authorized personnel as required, per the door hardware schedule. An intrusion detection system (IDS) will be provided at all doors within the secure area.

Windows: There will not be any exterior window openings in the facility.

Insulated Hollow Metal Doors: All frames will be factory prepared to receive door hardware. All exterior door thresholds will be flush within 1/4" of the exterior sidewalk. All exterior doors will be provided with hardware on the exterior side that allows for re-entry. All exterior exit doors will have flush type panic hardware and self-closing devices. No knock-down frames will be used for exterior doors. Insulated hollow metal doors will be 1-3/4 inches thick.

Interior Construction: For WALL TYPES "A", where listed as per IC TECH SPEC ICD/ICS 705 ver 1.5.1, the contractor shall follow the installation design guidelines per IC TECH SPEC FOR ICD/ICS 705 ver 1.5.1. Contractor shall also fasten acoustical insulation to studs to avoid slipping and ensure all stud cavities including headers and jambs are filled with acoustical insulation. The walls will have three layers 5/8 inch-thick gypsum wallboard (GWB), one layer on the uncontrolled side of the secure area and two on the controlled side of the secure area, to provide adequate rigidity and acoustic

protection (Sound Class 3). Wallboard shall be attached to 3 5/8 inch-wide 16 gauge metal studs or wooden 2 x 4 studs placed no less than 16" on center (o.c.). 16 gauge continuous track (top & bottom) w/ anchors at 32" o.c. maximum) – bed in continuous bead of acoustical sealant. The interior two layers of wallboard shall be mounted so that the seams do not align (i.e., stagger joints). Acoustic fill 3 1/2 " (89mm) sound attenuation material, fastened to prevent sliding down and leaving void at the top. The top and bottom of each wall shall be sealed with an acoustic sealant where it meets the slab. Fire safe non-shrink grout, or acoustic sealant in all voids above/below track both sides of partition. Entire wall assembly shall be finished and painted from true floor to true ceiling. All penetrations of perimeter walls shall be kept to a minimum. Utilities servicing areas other than the SCIF shall not transit the SCIF unless mitigated with AO approval. This restriction does not apply to secure communication lines required to transit a SCIF to service an adjacent SCIF through a common perimeter surface. Electrical Utilities should enter the SCIF at a single point. All utility (power and signal) distribution on the interior of a perimeter wall treated for acoustics or RF shall be surface mounted, contained in a raceway, or an additional wall shall be constructed using furring strips as stand-off from the existing wall assembly. If the construction of an additional wall is used, gypsum board may be 3/8 inch-thick and need only go to the false ceiling. Installation of additional conduit penetration for future utility expansion is permissible provided the expansion conduit is filled with acoustic fill and capped (end of pipe cover). Note: RF shielding will be on all 6 sides of the SCIF area. This will include the ceiling space in the SCIF area, the floor in the SCIF area, and the outside boundary of the SCIF. The internal walls, for instance the wall between the Security office and the Large Conference room, that wall will not have to be RF shielded. This only applies to the exterior walls that would be facing the area outside of the SCIF.

Interior Ceilings: Interior ceilings are located in the entry/waiting area, breakroom, mothers' room, restrooms, janitorial closet, secure vestibule, storage rooms, security room, collateral room, conference room, user server rooms, Labs and Lab Control Rooms, offices, and open offices. Ceilings are gypsum board mounted on 3 5/8-inch metal studs attached directly to the underside of structural trusses. The ceiling height will be 11-feet 7 1/2-inches, with most mechanical equipment exposed below the ceiling. One duct run will be above the gypsum ceiling due to area constraints. This duct run will utilize dielectric breaks, security bars, and dampers where necessary. Note: RF shielding will be on all 6 sides of the SCIF area. This will include the ceiling space in the SCIF area, the floor in the SCIF area, and the outside boundary of the SCIF. The internal walls, for instance the wall between the Security office and the Large Conference room, that wall will not have to be RF shielded. This only applies to the exterior walls that would be facing the area outside of the SCIF.

HVAC: HVAC ducts must be in accordance with the latest Sheet Metal and Air Conditioning National Association (SMACNA) publications and specifications. All vents and ducts shall be protected to meet the acoustic requirements of the SCIF. Walls surrounding duct penetrations shall be finished to eliminate any openings between the duct and the wall. All vents or duct openings that penetrate the perimeter of the SCIF

and exceed 96 square inches shall be protected with permanently affixed bars or grills.

- a. If one dimension of the penetration measures less than six inches, bars or grills are not required.
- b. When metal sound baffles or wave forms are permanently installed and set no farther apart than six inches in one dimension, then bars or grills are not required.
- c. If bars are used, they shall be a minimum of ½ inch diameter steel, welded vertically and horizontally six inches on center; a deviation of ½ inch in vertical and/or horizontal spacing is permissible.

If grilles are used, they shall be of:

- a. ¾ inch-mesh, #9 (10 gauge), case-hardened, expanded metal; or
- b. expanded metal diamond mesh, 1-1/2" #10 (1-3/8" by 3" openings, 0.093" thickness, with at least 80% open design) tamperproof; or
- c. welded wire fabric (WWF) 4x4 W2.9xW2.9 (6-gauge smooth steel wire welded vertically and horizontally four inches o.c.).

If bars, grilles, or metal baffles/wave forms are required, an access port shall be installed inside the secure perimeter of the SCIF to allow visual inspection of the bars, grilles, or metal baffles/wave forms. Protection bars shall be IAW UFC 4-010-05 October 2013. If the area outside the SCIF is controlled (SECRET or equivalent proprietary space), the inspection port may be installed outside the perimeter of the SCIF and be secured with an AO-approved high-security lock. This must be approval by the SSM, project manager and shall be noted in the Fixed Facility Checklist.

Acoustics: Because of the secure nature of the facility, enhanced acoustical control (STC-45 or STC-50) and RF shielding requirements, partitions will be constructed with gypsum board and metal studs. This includes sound attenuation blankets and conforming to ICD-705 ver 1.5.1 Type A.

Doors: All doors will be painted steel doors. Doors will meet the SC-50 or STC-55 rating, to match the STC rating of the wall. Doors and frames in the RF-shielded boundary perimeter will be RF-shielded and STC-50 rated. Hinge pins will be located on the inside of the area. Doors will have x10 locks, card readers, and additional hardware for access by

authorized personnel as required, per the door hardware schedule.

Floors: The Lab and Lab Control Rooms will have a raised access floor with the RF-shielded boundary at the recessed slab. The slab will have a self-leveler applied, to ensure flatness, RF foil installed on top of the self-leveled layer, followed by a ¼-inch backer board to protect the foil. Note: RF shielding will be on all 6 sides of the SCIF area. This will include the ceiling space in the SCIF area, the floor in the SCIF area, and the outside boundary of the SCIF. The internal walls, for instance the wall between the Security office and the Large Conference room, that wall will not have to be RF shielded. This only applies to the exterior walls that would be facing the area outside of the SCIF.

3.4. Security-In-Depth (SID):

This construction project will be located on the USAF installation Eglin AFB, Florida. This installation has a perimeter fence line with access control points that are manned 24/7 by armed USAF Security Forces personnel, with a minimum of a US Secret Clearance. These USAF personnel will provide armed response in case of emergencies, or as needed. The Security-in-Depth associated to this project includes:

- i) The project location is on a US Military Base with Security Forces (SF) accessing control and a dedicated response force of SFs, all of whom are US citizens.
- ii) The Secure Construction Site (SCS) will have perimeter fence surrounding the area(s) with pedestrian and vehicle gates accesses. The SCS is defined as the area within the construction site perimeter that is demarcated by a perimeter fence and access is controlled by the SSM staff. During non-working hours, the construction site shall be locked. The SCS perimeter shall include no less than a 2-meter standoff distance on both sides of the fence (i.e. no materials or other items can be stored within 2 meters of the fence) unless otherwise approved by the SSM. Changes and/or modifications to the SCS perimeter shall not be made without prior approval by the SSM and AO.
- iii) All personnel are subject to security inspections by the SSM Staff when entering/exiting the SCS.

3.5. Organizations, Roles and Responsibilities:

LRSO will occupy and operate the completed facility. LRSO will coordinate on functional requirements, transition plans, and operation and maintenance of the

completed facility.

Mobile District is the DOD designated design and construction agent for this project. Mobile District Resident Engineer: The Mobile District RE is the Mobile District resident engineer, Contracting Officer's Authorized Representative, and the Administrative Contracting Officer (ACO). During construction, the Mobile District RE will be responsible for the actual management of the day-to-day construction, contract administration and contract management of the project.

3.5.1. Defense intelligence Agency (DIA), Office of Security (SEC) serves as the Accrediting Official (AO) for the proposed SCIF.

3.5.2. HAF/A2 serves as the principal security office, as such review and coordinates issues with the AO and SSO AFMC.

3.5.3. AFMC/A2 serves as the principal security office for AFMC, as such approves all SCIF concepts, coordinates issues with CSA/AO, and provides security oversight and guidance for this project.

3.5.4. Eglin SSO serves as the serves as the immediate servicing SSO and provides security guidance and support for this project.

3.5.6. ORGANIZATION defines user requirements for (identify requirements).

4. RELEASABLE STATEMENT: The SSM with coordination through 96 CES Project Manager and 96 TW/XP2 (SSO) will determine what details of the SP is releasable. All construction plans and the documentation are unclassified. However, all plans and documentation will be maintained by the SSM in an authorized area. No release or discussion of classified information will conducted with the contractor.

5. RISK MANAGEMENT:

5.1. Risk/Threat Assessment:

The SSM and AO will jointly conduct and maintain the project's risk assessment, with the AO retaining the official document. This assessment will be reviewed and updated periodically to ensure that CSP measures remain aligned with the most current risk analysis.

5.2. Adjacencies to Consider:

This project is located on Eglin Air Force Base. All sides of the project site and end facility are within the base perimeter where the US government has full control. The closest adjacent point to this project that the US government does not have control is approximately 230meters. This point is the base perimeter and is a US Highway.

5.3. Prohibited Countries: Use of workers and resources from countries identified in the (SETL) as “critical technical threat level” or listed on the Department of State (DoS) Prohibited Countries Matrix is prohibited.

6. CONSTRUCTION SECURITY PROCESS:

6.1. Site Security Manager (SSM):

The SSM is the single point of contact for security matters related to this construction project. The SSM shall report operationally directly to the AO through the SSO.

The SSM for this project is:

Heath McGill

Heath.mcgill.3.ctr@us.af.mil

850-882-1218

6.2. SCIF ID: Provide the SCIF ID of the project:

TBD

6.3. Construction Timeframe:

6.3.1. Estimated Planning and Design Start Date:

September 2023

6.3.2. Estimated Construction Start Date:

December 1, 2025 (approximated date, will be updated by SSM accordingly)

6.3.2. Estimated Construction Completion Date:

September 30, 2027 (approximated date, will be updated by SSM accordingly)

6.4. Estimated cost for the SCIF construction project:

PA \$24M CWE \$18M; FITFA213201 FY25

6.5. Architectural and Design Company:

Black & Veatch, Knight Architects Sept 2023 to Present

4600 Village CT

Atlanta, GA 30338-5131

6.6. Consulting Firm/Company:

N/A

6.7. Contractor(s):

TBD

6.7.1. Primary Contractor:

TBD

6.7.2. Sub-Contractors:

TBD

Sub-Contractor Name	Services Provided	Timeframe
---------------------	-------------------	-----------

6.8. Roles and Responsibilities:

6.8.1. Overall Project Manager (OPM) shall be a U.S. citizen and possess a U.S. Top Secret/SCI clearance.

6.8.2. The Site Security Manager (SSM) shall be a U.S. citizen and possess a U.S. Top Secret/SCI clearance and is appointed in writing. Their responsibilities include:

6.8.2.1. Develops and implements the CSP.

6.8.2.2. Ensures the security integrity of the construction site until the facility has been accredited by the AO.

6.8.2.3. Shall have 24-hour unrestricted access to all parts of the construction site.

6.8.2.4. Shall conduct periodic security inspections for the duration of the project to ensure compliance with the CSP.

6.8.2.5. Shall document all security violations or deviations from the CSP and will immediately notify the Eglin SSO and the AO.

6.8.2.6. Shall develop and implement procedures to deny unauthorized personnel and material access to the construction site.

6.8.2.7. Shall maintain a roster of all workers used on the project which shall become part of the facility accreditation files.

6.8.2.8. Shall maintain copies of documentation related to this project, such as all documentation sent to/received from the AO, the work schedules, a list of all workers, access rosters, scope of work, bill of sales of materials, any meeting minutes on the project, inspection reports, reports of anomalies and any/all reports regarding security violation/deviations.

6.8.2.9. Shall work with the construction company/firm to ensure security of the construction site and compliance with requirements set forth in ICD 705 technical specifications are fulfilled.

6.8.2.10. Shall immediately notify the Eglin SSO and the AO if any construction requirements cannot be met.

6.8.2.11. Shall notify the Eglin SSO and the AO when the construction phase reached 60% and request a pre-accreditation inspection.

6.8.3. The Cleared American Guards (CAGs) shall be U.S. citizens and possess a U.S. Secret clearance. Their responsibilities include:

N/A

6.8.3.1. Shall perform access-control functions at all vehicle and pedestrian entrances to the site except as otherwise noted in the CSP.

6.8.3.2. Shall screen all non-cleared workers, vehicles and equipment entering or exiting the site.

6.8.3.3. Shall conduct random inspections of site areas and deny the introduction of prohibited materials as outlined in the CSP. All suspicious materials or incidents shall be brought to the attention of the SSM or CST.

6.8.4. Escorts shall be U.S. citizens and possess a U.S Top Secret/SCI clearance. Their responsibilities include:

6.8.4.1. Shall monitor uncleared construction workers during the close-in/finishing phases of construction and during any work conducted within an existing accredited SCIF to include any renovations/modifications whether minor or major.

6.9. Access Control

6.9.1. Installation/Compound Access:

All contractors and their employees that require access to any Eglin Air Force Base property will be required to obtain a picture ID from the Bass Pass and ID Office, and wear the ID at all times.

6.9.2. Construction Site Access:

Prior to initial access to the installation, all personnel must be listed on the approved SSM master access roster (or be an approved visitor), receive a briefing on security policies and procedures from the SSM or designee, and visibly display a site access badge issued by the General Contractor at all times while on the installation.

All personnel are subject to inspection by the SSM Staff upon entering, exiting, and at any time while on the installation.

6.9.3. Vehicle Access:

The General Contractor will establish and maintain a single vehicle control point to serve as the sole entry and exit for all vehicles accessing the installation. All vehicles entering or exiting the installation are subject to inspection by the SSM or their staff at this control point. The General Contractor is responsible for the initial construction and ongoing maintenance of the perimeter fence throughout the duration of this contract. Upon completion of the project and when the facility can be secured, the General Contractor will be responsible for removing the vehicle control point.

6.10. Procurement of Materials:

This project will adhere to the Buy American Act, ensuring that, to the maximum extent practicable, only domestic construction materials will be utilized in the completion of this project. Exceptions to this requirement will be considered only when domestic materials are unavailable, cost-prohibitive, or inconsistent with the public interest, as determined in accordance with applicable regulations and procedures.

Full name of business to include complete address	Material Procured
---	-------------------

6.12. Secure Storage Area (SSA) of Construction Material:

All construction materials shall remain in the designated staging area until ready for use. Storage of materials in areas other than the designated area will not be allowed.

6.13. Construction Personnel Requirements:

6.13.1. Citizenship Requirements:

All construction and design work will be performed by US companies using US Citizens and US Persons.

6.13.1.1. General Construction: U.S. Citizens will be utilized for the unclassified work conducted during construction of the internal open framing phase.

6.13.1.2. Finished Construction: U.S. Citizens will be utilized for the work conducted during the finishing phase and during any phase where work infrastructure to support the classified mission and/or operations.

6.13.1.3. TEMPEST Countermeasures: U.S. citizens from U.S. companies/firms will be utilized in the installation of TEMPEST Countermeasures required by the AO CTTA. Foreign nationals WILL NOT be utilized in the installation of any SCI cabling installation.

6.13.1.4. SCI Installation: U.S. TOP SECRET/SCI-cleared personnel will be utilized for the SCI work conducted during the finishing phase to include the installation of the Information Technology (IT) infrastructure. When construction situations prohibit the

utilization of SCI cleared persons for installation projects then SCI-cleared persons will be utilized to escort unclassified U.S. citizens during the installation of the IT cabling infrastructure. Foreign nationals WILL NOT be utilized in the installation of any SCI cabling installation.

6.13.1.5. Intrusion Detection Systems (IDS) Installation: U.S. citizens from U.S. companies/firms will be utilized for the installation and testing of all IDS components and elements within the facility. Foreign nationals WILL NOT be utilized in the installation and testing of the IDS.

6.13.1.6. Spin Dial Combination Locks Installation: U.S. citizens from U.S. companies/firms will be utilized for the installation and maintenance of all spin dial combination locks within the facility. Foreign nationals WILL NOT be utilized in the installation and testing of the locks.

6.13.1.7. Access Control Devices (ACS) Installation: U.S. citizens will be utilized in the installation, testing and maintenance of the ACS.

6.13.2. Clearance Requirements

6.13.2.1. General Construction: U.S. Cleared (list clearance(s) workers to include unclassified U.S. citizens will be utilized for the unclassified work conducted during construction of the internal open framing phase.

6.13.2.2. Finishing Construction: U.S. Cleared workers to include unclassified U.S. citizens will be utilized for the work conducted in designated Controlled spaces during the finishing phase. All construction projects will follow recommendation that all finish work will be accomplished by either U.S. SECRET or U.S. TOP SECRET-cleared U.S. personnel.

6.13.2.3. SCI Installation: U.S. TOP SECRET/SCI-cleared personnel will be utilized for the SCI work conducted during the finishing phase to include the installation of the IT infrastructure. When construction situations prohibit the utilization of SCI-cleared persons for installation projects then U.S. TOP SECRET/SCI-cleared personnel will be utilized to escort unclassified U.S. citizens during the installation of the IT cabling infrastructure. Foreign nationals WILL NOT be utilized in the installation of any SCI IT infrastructure.

6.13.2.4. IDS Installation: U.S. TOP SECRET-cleared workers shall conduct the installation and testing of all IDS components and elements. If U.S. SECRET-cleared workers are used then they will be escorted by U.S. TOP SECRET/SCI- cleared personnel. Foreign nationals WILL NOT be utilized in the installation and testing of the IDS.

6.13.2.5. Spin Dial Combination Locks Installation: U.S. SECRET or U.S. TOP SECRET cleared personnel from U.S. companies/firms will be utilized for the installation and

maintenance of all spin dial combination locks for the facility. Foreign nationals WILL NOT be utilized in the installation and testing of the locks.

6.13.2.6. Access Control Devices (ACS) Installation: U.S. SECRET or U.S. TOP SECRET-cleared personnel from U.S. companies/firms will be utilized installation and programming of the ACS.

6.13.3. Validation/confirmation requirements of Workers:

The USACE shall create a Master Access Roster (MAR) for use on this project that will identify all individual/s who are approved for entry to the installation and/or project information access and separately, shall identify anyone who has been denied for use on this project. This list shall be provided to the SSM by the USACE.

6.13.3.1. U.S. Government personnel will request a check through the National Crime Information Center (NCIC) is utilized for all potential employees to ensure they do not have warrants, warrants or any other derogatory information that keeps them from being validated. The government also ensures via the NCIC that names do not appear on any federal watch lists, and that non-U.S. citizens are approved to work in the U.S. upon completion of the validation process, the government will notify the contractor which employees are cleared and which employees, if any, will not be allowed on the construction site. Construction workers will only be allowed in the construction area after successfully completing this validation process.

6.13.3.2. All contractors and subcontractors will provide all workers name to (list the office) to be validated at least 30 days prior to being allowed on the construction site. The prime contractor will provide the following employee information either in hard copy or electronically using an excel spreadsheet. Either format should have the appropriate privacy act warnings and electronic files must be encrypted or password protected.

6.13.3.2.1. Full first, middle and last name to include any aliases

6.13.3.2.2. Date of birth and place of birth

6.13.3.2.3. Full social security number

6.13.3.2.4. State identification or drivers license number to include state of issue

6.13.3.2.5. If not a U.S. citizen, nationality and Immigration and Naturalization Service number.

6.13.3.2.6. Declare any felony convictions or pending court appearances on felony charges. Declare any misdemeanor convictions involved crimes of violence or drug use.

6.13.3.2.7. Declare any foreign continuous or routine contacts, to include name of foreign person, country and citizenship.

6.13.3.3. Government personnel will ensure potential employees do not have warrants for arrest, their names do not appear on any federal watch lists, and that non-U.S. citizens are approved to work in the U.S. Upon completion of the validation process, the government will notify the contractor which employees are cleared and which employees, if any, will not be allowed on the construction site. After receiving notification only will construction workers will be allowed in the construction area.

8. Security Administration:

8.1. Control of Construction Plans and Documents:

Only US Government or Official Contractor systems employing commercially available technical and information assurance controls are authorized for the storage, safeguarding, and transmission/receipt of email, tasking directives, and other correspondence pertaining to this project. The use of private email services, including but not limited to Gmail, Yahoo, Hotmail, Facebook, and WhatsApp, is strictly prohibited.

8.2. Personnel Conduct:

Any individual who violates the requirements of this CSP, willfully disregards or refuses to comply with directives from SSM Staff, or creates an increased risk (whether intentional or unintentional) to the overall project may be immediately removed from the project by the SSM. Such removal may be temporary or permanent and may encompass the installation or the entirety of the project, including revocation of access to designs, plans, meetings, and other project-related activities. Removal from the project shall be considered a measure of last resort by the SSM, exercised only when deemed necessary to protect the integrity of the facility and/or the operational mission of the end user. Removal from the project due to security violations shall be at no cost to the US Government

8.2.1. All employees shall comply with the conduct requirements in effect at the construction/work site. An acceptable standard of conduct and dress shall prevail at the construction site at all times. Shirts shall be worn at all times. The USG reserves the right to exclude or remove from the site any personnel whom the USG deems careless, uncooperative, or whose continued presence on the work site is deemed by the USG to be contrary to the public interest.

8.2.2. The contractor shall maintain satisfactory standards of employee conduct, appearance, integrity and shall be responsible for taking such disciplinary action with respect to employees as may be necessary. Each contractor employee will adhere to standards of conduct that reflect credit on themselves, their employer and the USG. Construction security personnel will, at all times, be courteous when dealing with visitors to the construction site.

8.2.3. The contractor shall inform its employees that the USG does not tolerate any harassing behavior or horseplay at any times. Any contractor employee who is found to be culpable in incidents of harassment shall be immediately escorted from the premises and denied further access. The contractor shall emphasize to its employees that the USG's policy on harassment may be stricter than the policy the contractor would otherwise impose. Exclusion under the circumstances described in this clause shall not relieve the contractor from full performance of the requirements of this contract, nor will it provide the basis for any claims against the USG.

8.2.4. The contractor is responsible for notifying the SSM of any terminations of employees, removal from the work site, or any other circumstances that would deem the employee to no longer have the need to access the work site within 24 hours to include the cause. If the SSM deems removal of a worker to be needed, they will escort the worker to the contractors' trailer and notify the contractor of the situation.

8.3. Visitor logs:

The General Contractor is responsible for maintaining a visitor log.

Log Format and Content: Standardized visitor logs shall be utilized, capturing the following information:

- Date and time of entry/exit.
- Full name of visitor.
- Organization/company affiliation.
- Purpose of visit.
- Escort (if applicable).
- Areas visited.
- Signature of visitor.
- Signature of escort/security personnel.

Escorting Requirements: All visitors, regardless of clearance level, must be escorted by appropriately cleared personnel within the construction site. The escort is responsible for ensuring visitor adherence to security protocols and preventing access to unauthorized areas.

Log Storage and Handling: Visitor logs must be stored securely within a designated secure area on the construction site, utilizing a locked container such as a safe or a locked file cabinet.

Regular Reviews and Audits: The SSM shall regularly review visitor logs to identify any anomalies or security breaches. Periodic audits may also be conducted by the sponsoring agency to ensure compliance with applicable security regulations.

Retention and Disposal: Visitor logs shall be retained for a period specified by the sponsoring agency's security directives. Upon reaching the end of the retention period, the logs must be destroyed in accordance with approved procedures, typically by cross-cut shredding or incineration.

8.4. Safety Issues:

The General Contractor bears sole responsibility for maintaining safety on the project site; neither the SSM nor SSM Staff shall be held accountable for site safety. SSM Staff members will not interfere with the duties and responsibilities of designated safety officers unless a situation directly impacts the security of this project. Conversely, safety officers will not impede the operations of the SSM Staff unless a life-threatening situation arises. Non-life-threatening issues pertaining to SSM Staff shall be reported directly to the SSM and/or USACE. The SSM shall ensure that all SSM Staff members perform their assigned duties and responsibilities in a safe and lawful manner, adhering to all applicable US and local laws.

8.5. Emergency Incidents:

Incidents may occur that necessitate an emergency response from both government and General Contractor safety personnel. The SSM retains responsibility for all security decisions during any emergency or accident, and at all times. Life safety considerations shall take precedence over security protocols. In the event of an emergency or accident requiring external assistance (e.g., fire services, paramedics, or Security Forces), SSM Staff on the project site shall utilize telecommunication devices to notify all necessary personnel of the need for emergency services (NOTE: during a bomb threat, radio communication is prohibited within the project site). The SSM shall also notify the General Contractor and the USACE. Emergency response personnel will be granted immediate and unimpeded access to the emergency location within the installation. Immediate and unimpeded access will not be granted to non-emergency personnel. SSM Staff shall monitor all emergency personnel on the installation as closely as practicable, without interfering with their operations and

while maintaining a safe distance. Emergency personnel shall be subject to search upon exiting the installation, contingent upon the adequate resolution of the emergency. Should emergency personnel need to depart the site as part of their emergency operations (e.g., an ambulance transporting an injured individual), they will be granted immediate and unimpeded egress from the installation.

8.6. Security Incidents: A security incident is defined as a breach, deliberate or inadvertent, of any security related term or condition, any DoD and/or DNI security policy or procedure, or any guidance of the CSP. All suspected security incidents must be immediately reported to the SSM. All personnel are required to cooperate fully with any investigation of the security breach and must assist in resolving any suspected or actual security incident.

8.6.1. Reporting Requirements: Any all security concerns, issues, incidents and/or suspected violations will be immediately brought to the attention of the SSM. It is the responsibility of all personnel involved in the construction project to abide by this requirement. Failure to report a security incident will be viewed as an incident itself and can lead to shutting down the construction site and the involvement of the COR. All security incidents and violations will be reported to the SSM within 72 hours of initial discovery/report.

8.6.2. Investigation/Resolution: The SSM will work with the Eglin SSO to investigate and resolve every reported security incident or violation. Documentation of the investigative results will be forwarded to the SSO AFMC, CSA and the AO and become a part of the official record of the project.

8.6.3. Cost/Schedule Impacts: The U.S. government will not be held responsible for any security incident that creates an impact to the schedule and/or costs, when the investigation by the SSM/SSO determines the fault to be an error or responsibility from the personnel employed by the contractor/sub-contractor.

8.7. Prohibited Items: ****NOTE**** - It's the responsibility of the SSM's and unit/organization to provide detailed information regarding these topics

8.7.1. No photographic and/or video recording devices shall be permitted on the construction site without the express written permission of the SSM. This prohibition includes all personally owned cell phones, personal digital assistants (PDA), Blackberry, personally owned laptops/tablets, cameras and similar devices. Persons having a need for photographic support will coordinate their request through Eglin SSO prior to admitting on-site.

8.7.2. Drugs, narcotics, barbiturates, marijuana, controlled substances, drug paraphernalia and alcohol are prohibited. Medicines are approved for use if they are

prescribed by a U.S. medical practitioner or are approved as over-the-counter by the U.S. Food and Drug Administration (FDA).

8.7.3. Ammunition or other explosives which include a gun and similar tool ammunition are allowed with prior notification to the SSM and CAG before entering the construction site. Equipment shall be transported, stored, handled and used in accordance with industry best practices, state or federal laws and codes and the construction company instructions (whichever is the most restrictive).

8.7.4. Any firearm, instrument, or mechanism capable of firing a projectile to include BB or pellet (CO2 and air) guns. Any replicas and realistic looking toy weapons to include starter guns. Any dagger, dirk switchblade, butterfly knife, stiletto, or any other unusually dangerous instrument capable of inflicting cutting, stabbing, or tearing wounds. Pocket knives under three and one half inches are authorized. Not authorized are brass or iron knuckles defined as any instrument that consists of finger rings or guards made of a hard substance that is designed, made, or adapted for the purpose of inflicting injury by striking any person. Items specifically designed or modified as an offensive weapon, such as modified baseball bats, ax handles, clubs, or chains are not authorized. Martial arts instruments including, but not limited to, nunchuks/nunchakus, throwing stars, and tonfas are not authorized nor are items specifically designed as defensive weapons, such as chemical defensive sprays (mace), pepper spray, stun guns, and Tasers or any type of explosives, fireworks, or flares.

8.7.5. Any person found with any prohibited items on the construction site shall have the item(s) seized and with the possibility of being destroyed with no liability to be incurred by Eglin SSO office, U.S. Government or its contractors. The individual will be immediately removed from the construction site to include possibly being arrested and denied access to the construction site thereafter.

8.8. Photographic Documentation and control:

8.8.1. Cameras that are owned by U.S. government organizations or U.S. construction firms shall only be permitted on the construction site with the express written authorization by the SSM. Camera authorization letters will be issued to all authorized users by the SSM. The authorization letter shall state a specific period which will be at the discretion of the SSM that the user will be allowed to take photographs on the construction site. The camera shall be secured at all times and the authorization letter shall be on the authorized user at all times when pictures are being taken. ***There will be NO EXCEPTIONS to this rule.*** All pictures taken shall be reviewed by the SSM prior to removing the camera from the construction site.

8.8.2. During the construction phase photographs may be taken to show the progression of the site. If a camera is utilized, all aspects of the build-out should be

photographed with emphasis on specific instances, which will include but are not limited to:

8.8.2.1. The construction company will not post any information and/or pictures with regards to the construction project during and after the construction project has been completed.

8.8.2.2. Construction materials being used prior to installation showing the make/model of the item (i.e. sound attenuation blanket, man bars, RF foil, etc.)

8.8.2.3. Installation of wallboard framing for the SCIF perimeter

8.8.2.4. Installation of the acoustical fill/materials between the framing studs and from the true-floor to the true ceiling of the SCIF perimeter and any CA that will be supporting a controlled program within the SCIF.

8.8.2.5. Installation of wallboard on the SCIF perimeter in particular clearly showing the interior two layers of wallboard are mounted so that the seams do not align (i.e. stagger joints).

8.8.2.6. Installation/application of TEMPEST Countermeasures (i.e. Radio Frequency (RF) etc.)

8.8.2.7. Identifying that the entire SCIF perimeter wall assembly has been professionally constructed/finished and painted from the true-floor (below the false floor) to the true-ceiling (above the false ceiling).

8.8.2.8. Installation of Heating Ventilation and Air Conditioning (HVAC) components to include non-conductive breaks, man-bars, sound/wave baffles and inspection ports

8.8.2.9. Identifying all wall penetrations on the SCIF perimeter to include power, telecom, IT, HVAC and pipes.

8.8.3. The SSM and/or SSO can identify additional circumstances (i.e. safety concerns, practices dangerous to security) that may require the use of photographic

8.8.4 Pictures can be taken and shall be labeled to show construction progress. Pictures taken shall be downloaded from the camera to an authorized computer software program.

9. ACOUSTICAL TESTING:

The Contractor shall engage and compensate qualified, independent testing and inspection agencies to conduct field tests and inspections, and to prepare reports as mandated by specification sections requiring such assessments. Specifically, the Contractor shall ensure the performance of Sound Transmission Class (STC)

Instrumental Testing in accordance with ICD-705 and Chapter 9 of the Technical Specifications for ICD/ICS-705 for the secure space within the building. The testing methodology provided by the security contractor must adhere to the ASTM E336 standard test method for measurement of airborne sound attenuation between rooms in buildings, predicated upon ASTM E90 Laboratory Measurement of Airborne Sound Transmission Loss of Building Partitions and Elements. The Contracting Officer or their designated Representative shall bear no responsibility for engaging these services.

10. HISTORICAL RECORDS: The SSM shall maintain relevant historical records and documents of this project. At the conclusion of the project, all relevant historical records and documents will be forwarded to the unit Eglin SSO to be maintained as a permanent record with the SCIF

11. REVISION PROCESS:

11.1. Effective period: This Construction Security Plan (CSP) is effective immediately and will be revised on an as needed basis.

11.2. Revision Authority: Changes within the construction schedule may require more immediate changes. Only the SSM in agreement with the Eglin SSO can make revisions to this document.

11.3. Revision Process:

11.3.1. Requirement for revision identified

11.3.2. Revision Change Form utilized for all changes

11.3.3. Co-approval required between SSM and Eglin SSO

11.3.4. Revision approved

11.3.5. CSP revised

11.3.6. Change form added to document

11.3.7. Revision number added/updated on CSP

11.3.8. CSP saved with new revision number

11.3.9. Revised CSP submitted to AO for approval

UNCLASSIFIED

APPENDIX A

ACROYNYS

ACS Access Control Systems

AO Accrediting Official

CA Compartmented Area

CAG Cleared American Guard

CI Counterintelligence

CSA Cognizant Security Authority

CSP Construction Security Plan

CST Construction Surveillance Technician

FDO Foreign Disclosure Officer

HVAC Heating Ventilation and Air Conditioning

ICD Intelligence Community Directive

ICS Intelligence Community Standards

IDS Intrusion Detection Systems

IT Information Technology

RF Radio Frequency

SAP Special Access Program

SCI Sensitive Compartmented Information

SCIF Sensitive Compartmented Information Facility

SETL Security Environment Threat Listing

SSM Site Security Manager

SSR Special Security Representative

SSO Special Security Officer

UNCLASSIFIED

APPENDIX B

DEFINITIONS

Site Security Manager - A designated TOP SECRET/SCI-cleared USG representative to the COR for all site security matters involving SCIF construction projects.

Construction Security Technician - A TOP SECRET-cleared U.S. citizen who is specially trained in surveillance and construction trade to deter technical penetrations and thwart implanted technical collection devices and assigned to a project for the purpose of ensuring the security integrity of a site, building, SCIF and materials and items that are scheduled for use or inclusion in a SCIF.

UNCLASSIFIED

UNCLASSIFIED

APPENDIX C
SUMMARY OF REVISIONS

UNCLASSIFIED